

Magelis Easy GXU User Manual

01/2015



EIO0000002073.01

www.schneider-electric.com

Schneider
Electric

The information provided in this documentation contains general descriptions and/or technical characteristics of the performance of the products contained herein. This documentation is not intended as a substitute for and is not to be used for determining suitability or reliability of these products for specific user applications. It is the duty of any such user or integrator to perform the appropriate and complete risk analysis, evaluation and testing of the products with respect to the relevant specific application or use thereof. Neither Schneider Electric nor any of its affiliates or subsidiaries shall be responsible or liable for misuse of the information contained herein. If you have any suggestions for improvements or amendments or have found errors in this publication, please notify us.

No part of this document may be reproduced in any form or by any means, electronic or mechanical, including photocopying, without express written permission of Schneider Electric.

All pertinent state, regional, and local safety regulations must be observed when installing and using this product. For reasons of safety and to help ensure compliance with documented system data, only the manufacturer should perform repairs to components.

When devices are used for applications with technical safety requirements, the relevant instructions must be followed.

Failure to use Schneider Electric software or approved software with our hardware products may result in injury, harm, or improper operating results.

Failure to observe this information can result in injury or equipment damage.

© 2015 Schneider Electric. All rights reserved.

Table of Contents



	Safety Information	5
	About the Book	7
Chapter 1	HMIGXU Panels	9
	Package Contents	10
	Parts Identification and Functions	11
	Certifications and Standards	13
	HMIGXU Series of Panels	14
Chapter 2	Device Connectivity	17
	System Design	18
	Accessories	21
Chapter 3	Specifications	23
3.1	General Specifications	24
	Specifications	24
3.2	Functional Specifications	27
	Display Specifications	28
	Memory, Clock, and Touch Panel	29
3.3	Interface Specifications	30
	Interface Specifications	31
	Serial Interface Specifications RS-232C	33
	Serial Interface Specifications RS-422/485	35
	USB Port	37
	Ethernet Port	39
3.4	Dimensions	41
	HMIGXU35•• Dimensions	42
	HMIGXU55•• Dimensions	43
	Panel-cut Dimensions	45
	Installation Fasteners	46
Chapter 4	Installation and Wiring	47
4.1	Installation	48
	Installation Procedures	49
	Real Time Clock (RTC)	53
4.2	Wiring Principles	55
	Connecting the Power Cord	56
	Connecting the Power Supply	58
	Grounding	60

4.3	USB Port	62
	USB Type A Installation	62
Chapter 5	Maintenance	65
	Precaution	66
	Periodic Check Points	67
	Regular Cleaning	68
Index	69

Safety Information



Important Information

NOTICE

Read these instructions carefully, and look at the equipment to become familiar with the device before trying to install, operate, or maintain it. The following special messages may appear throughout this documentation or on the equipment to warn of potential hazards or to call attention to information that clarifies or simplifies a procedure.



The addition of this symbol to a “Danger” or “Warning” safety label indicates that an electrical hazard exists which will result in personal injury if the instructions are not followed.



This is the safety alert symbol. It is used to alert you to potential personal injury hazards. Obey all safety messages that follow this symbol to avoid possible injury or death.

DANGER

DANGER indicates a hazardous situation which, if not avoided, **will result in** death or serious injury.

WARNING

WARNING indicates a hazardous situation which, if not avoided, **could result in** death or serious injury.

CAUTION

CAUTION indicates a hazardous situation which, if not avoided, **could result in** minor or moderate injury.

NOTICE

NOTICE is used to address practices not related to physical injury.

PLEASE NOTE

Electrical equipment should be installed, operated, serviced, and maintained only by qualified personnel. No responsibility is assumed by Schneider Electric for any consequences arising out of the use of this material.

A qualified person is one who has skills and knowledge related to the construction and operation of electrical equipment and its installation, and has received safety training to recognize and avoid the hazards involved.

About the Book



At a Glance

Document Scope

This manual describes how to use the HMIGXU panels.

Validity Note

This documentation is valid for Vijeo Designer Basic V1.0 or higher.

The technical characteristics of the devices described in this document also appear online. To access this information online:

Step	Action
1	Go to the Schneider Electric home page www.schneider-electric.com .
2	In the Search box type the reference of a product or the name of a product range. <ul style="list-style-type: none">● Do not include blank spaces in the model number/product range.● To get information on grouping similar modules, use asterisks (*).
3	If you entered a reference, go to the Product Datasheets search results and click on the reference that interests you. If you entered the name of a product range, go to the Product Ranges search results and click on the product range that interests you.
4	If more than one reference appears in the Products search results, click on the reference that interests you.
5	Depending on the size of your screen, you may need to scroll down to see the data sheet.
6	To save or print a data sheet as a .pdf file, click Download XXX product datasheet .

The characteristics that are presented in this manual should be the same as those characteristics that appear online. In line with our policy of constant improvement, we may revise content over time to improve clarity and accuracy. If you see a difference between the manual and online information, use the online information as your reference.

Related Documents

Title of Documentation	Reference Number
HMIGXU Installation Guide	EAV83639 (Eng and Chs)

You can download these technical publications and other technical information from our website at www.schneider-electric.com.

 **DANGER**

HAZARD OF ELECTRIC SHOCK, EXPLOSION OR ARC FLASH

- Disconnect all power from all equipment including connected devices before removing any covers or doors, or installing or removing any accessories, hardware, cables, or wires except under the specific conditions specified in the appropriate hardware guide for this equipment.
- Always use a properly rated voltage sensing device to confirm that the power is off.
- Unplug the power cable from both the equipment and the power supply.
- Replace and secure all covers, accessories, hardware, cables, and wires and confirm that a proper ground connection exists before applying power to the equipment.
- Use only the specified voltage when operating this equipment and any associated products.

Failure to follow these instructions will result in death or serious injury.

 **WARNING**

LOSS OF CONTROL

- Consider the potential failure modes of control paths in the machine control system design, such as:
 - the possibility of backlight failure,
 - unanticipated link transmission delays or failures,
 - the operator being unable to control the machine,
 - the operator making errors in the control of the machine.
- Provide a means to achieve a safe state during and after a path failure for critical control functions such as emergency stop and overtravel stop.
- Provide separate or redundant control paths for critical control functions.
- Test individually and thoroughly each implementation of the panel for correct operation before service.

Failure to follow these instructions can result in death, serious injury, or equipment damage.

 **WARNING**

UNINTENDED EQUIPMENT OPERATION

- Only use software approved by Schneider Electric for use with this equipment.
- Update your application program every time you change the physical hardware configuration.

Failure to follow these instructions can result in death, serious injury, or equipment damage.

Chapter 1

HMIGXU Panels

Overview

This chapter describes the series of panels and connectable devices.

What Is in This Chapter?

This chapter contains the following topics:

Topic	Page
Package Contents	10
Parts Identification and Functions	11
Certifications and Standards	13
HMIGXU Series of Panels	14

Package Contents

Overview

Make sure that all applicable items listed here are included in the panel package:

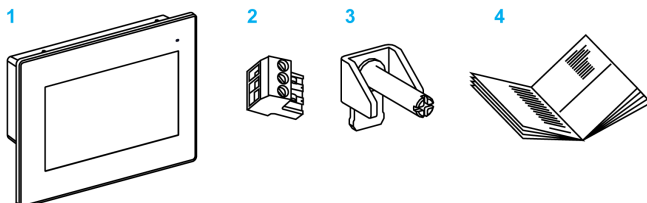

- 1 Panel
- 2 DC power connector
- 3 Screw installation fasteners (HMIGXU3500 and HMIGXU3512 x 4, HMIGXU5500 and HMIGXU5512 x 6)
- 4 HMIGXU Installation guide

Revision

You can identify the product version (PV), revision level (RL), and the software version (SV) from the product label on the panel.

This diagram is a representation of a typical label:

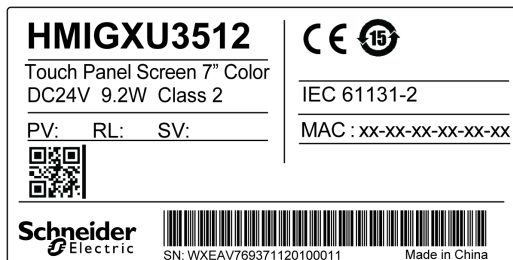

Parts Identification and Functions

Front View

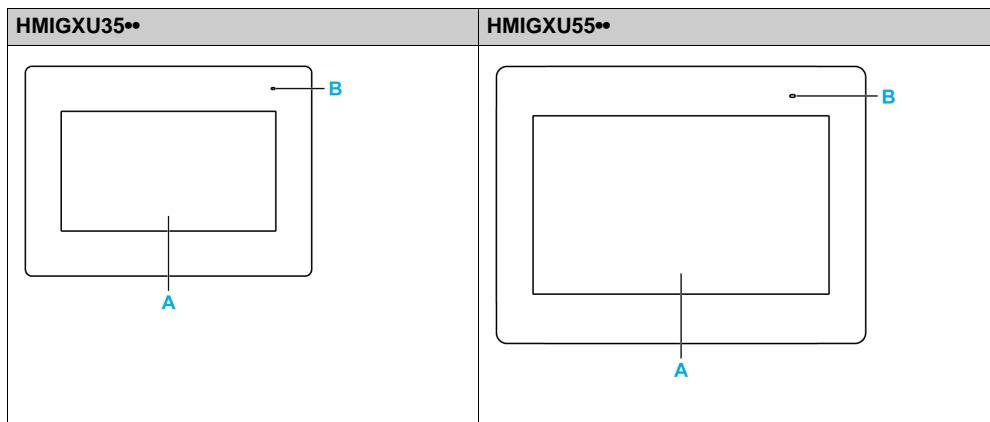

Part	Description
A	Touch panel
B	LED indicator

Rear View

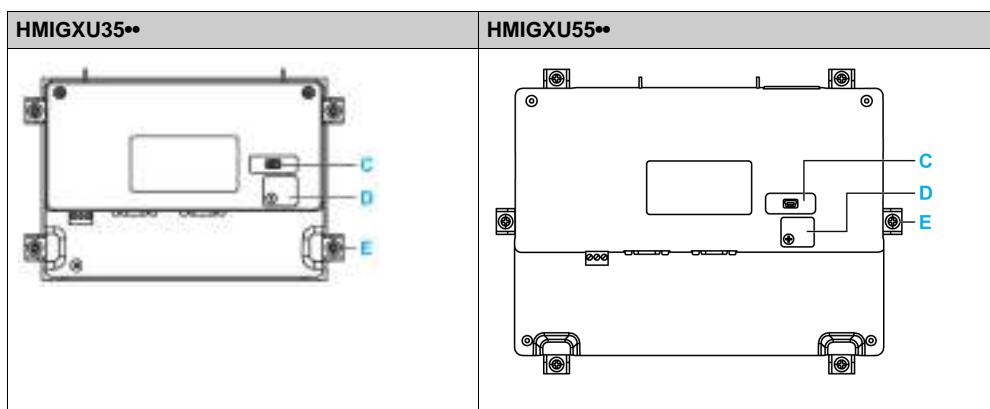

Part	Description
C	USB mini B
D	Locker USB Type A only for HMIGXU3512 and HMIGXU5512
E	Screw installation fasteners: <ul style="list-style-type: none"> ● HMIGXU3500 and HMIGXU3512 x 4 ● HMIGXU5500 and HMIGXU5512 x 6

Bottom View

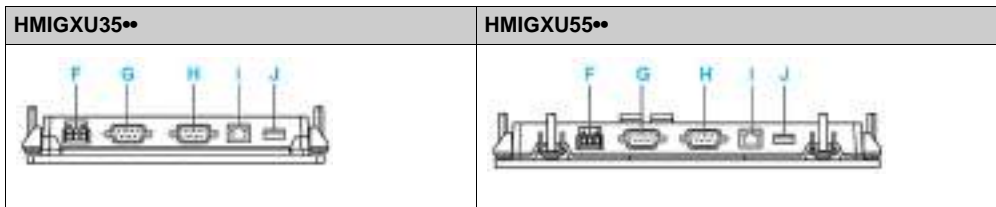

Part	Description
F	Power connector
G	Serial interface RS-232C only for HMIGXU3512 and HMIGXU5512
H	Serial interface RS-422/485
I	Ethernet only for HMIGXU3512 and HMIGXU5512
J	USB Type A only for HMIGXU3512 and HMIGXU5512

Certifications and Standards

Compliance Standards

Schneider-Electric submitted this product for independent testing and qualification by third party listing agencies.

Schneider-Electric and these agencies have certified this product as meeting the following standards:

- Directive 2006/95/EC (Low voltage)
- Directive 2004/108/EC (EMC).

The panels are CE marked.

- EMI: EN61000-6-4
- EMS: EN61000-6-2
- EMS: EN61131-2
- IP65 (front face) - IP20 (rear)

Qualification Standards

Schneider-Electric voluntarily tested this product to additional standards. The additional tests performed, and the standards under which the tests were conducted, are specifically identified in Environmental Characteristics (*see page 24*).

Hazardous Substances

The HMIGXU series are designed for compliance with:

- WEEE, Directive 2002/96/EC
- REACH, Regulation N° 1907/2006 on the Registration, Evaluation, Authorisation of Chemicals

This product is compliant with:

- RoHS European
- RoHS China

Hazardous Location

 DANGER
RISK OF EXPLOSION IN HAZARDOUS LOCATION
Do not use this product in hazardous location.
Failure to follow these instructions will result in death or serious injury.

HMIGXU Series of Panels

Introduction

This topic presents the HMIGXU series of human-machine interface (HMI) products. The features of the screen technology are color and TFT (Thin Film Transistors also known as active matrix) with WVGA pixel resolution. The operating voltage is 24 Vdc. The products offered in this series have various features and benefits listed below:

- Screen size
- RTC battery
- Communication interfaces

HMIGXU Part Numbers

The table presents the different HMIGXU panels:

Part number	Screen size	USB type A	USB type mini B	Ethernet	RS-232	RS-422 RS-485	RTC battery	User application
HMIGXU3500	17.78 cm (7 in.)	No	Yes	No	No	Yes	Yes	32 MB
HMIGXU3512	17.78 cm (7 in.)	Yes	Yes	Yes	Yes	Yes	Yes	48 MB
HMIGXU5500	25.65 cm (10.1 in.)	No	Yes	No	No	Yes	Yes	32 MB
HMIGXU5512	25.65 cm (10.1 in.)	Yes	Yes	Yes	Yes	Yes	Yes	48 MB

Critical Systems, Alarms, and Handling Requirements

Critical alarm indicators and system functions require independent and redundant protection for hardware and/or mechanical interlocks.

When you cycle power, wait at least 1 second before restoring the power to the panel after it has been turned off. Switching the power OFF and ON quickly can damage the panel.

In the event the screen cannot be properly read, for example, if the backlight is not functioning, it may be difficult or impossible to identify a function. Functions that may present a hazard if not immediately executed, such as a fuel shut-off, must be provided independently of the panel. The design of the control system of the machine must take into account the possibility of the backlight no longer functioning and the operator being unable to control the machine or making mistakes in the control of the machine.

WARNING

LOSS OF CONTROL

- Consider the potential failure modes of control paths in the machine control system design, such as:
 - the possibility of backlight failure,
 - unanticipated link transmission delays or failures,
 - the operator being unable to control the machine,
 - the operator making errors in the control of the machine.
- Provide a means to achieve a safe state during and after a path failure for critical control functions such as emergency stop and overtravel stop.
- Provide separate or redundant control paths for critical control functions.
- Test individually and thoroughly each implementation of the panel for correct operation before service.

Failure to follow these instructions can result in death, serious injury, or equipment damage.

WARNING

UNINTENDED EQUIPMENT OPERATION

- Do not use this equipment as the only means of control for critical system functions such as motor start/stop or power control.
- Do not use this equipment as the only notification device for critical alarms, such as device overheating or overcurrent.

Failure to follow these instructions can result in death, serious injury, or equipment damage.

Handling the LCD Panel

The following characteristics are specific to the LCD panel and are considered normal behavior:

- LCD screen may show unevenness in the brightness of certain images or may appear different when seen from outside the specified viewing angle. Extended shadows, or crosstalk may also appear on the edges of screen images.
- LCD screen pixels may contain black and white-colored spots and the color display may look as if it is changing.
- When the same image is displayed on the panel screen for a long period, an after-image may appear after changing the image. If this happens, turn OFF the panel, wait 1 second, and then restart the panel.

NOTE: Change the screen image periodically and try not to display the same image for a long period time.

CAUTION

SERIOUS EYE AND SKIN INJURY

The liquid in the LCD panel contains an irritant:

- Avoid direct skin contact with the liquid.
- Wear gloves when you handle a broken or leaking unit.
- Do not use sharp objects or tools in the vicinity of the LCD touch panel.
- Handle the LCD panel carefully to prevent puncture, bursting, or cracking of the panel material.

Failure to follow these instructions can result in injury or equipment damage.

If the panel is damaged and any liquid comes in contact with your skin, immediately rinse the area with running water for at least 15 minutes. If the liquid gets in your eyes, immediately rinse your eyes with running water for at least 15 minutes and consult a doctor.

Chapter 2

Device Connectivity

Overview

This chapter presents the equipments that you can connect to the HMIGXU panel.

What Is in This Chapter?

This chapter contains the following topics:

Topic	Page
System Design	18
Accessories	21

System Design

Introduction

The diagrams represent the main equipments that you can connect to the panels.

Edit Mode Peripherals

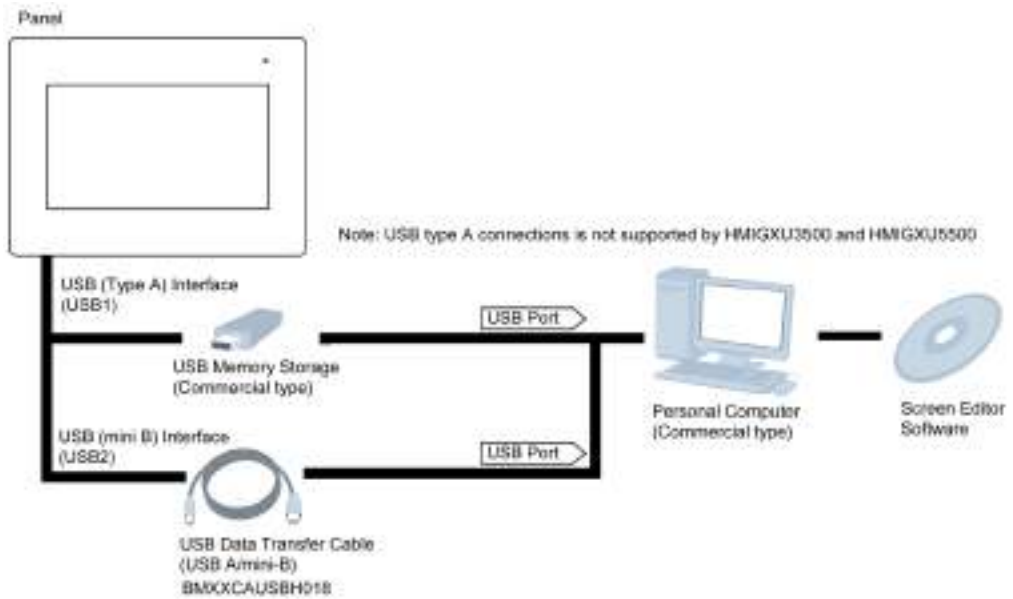

Run Mode Peripherals - USB Type A/mini B Interface

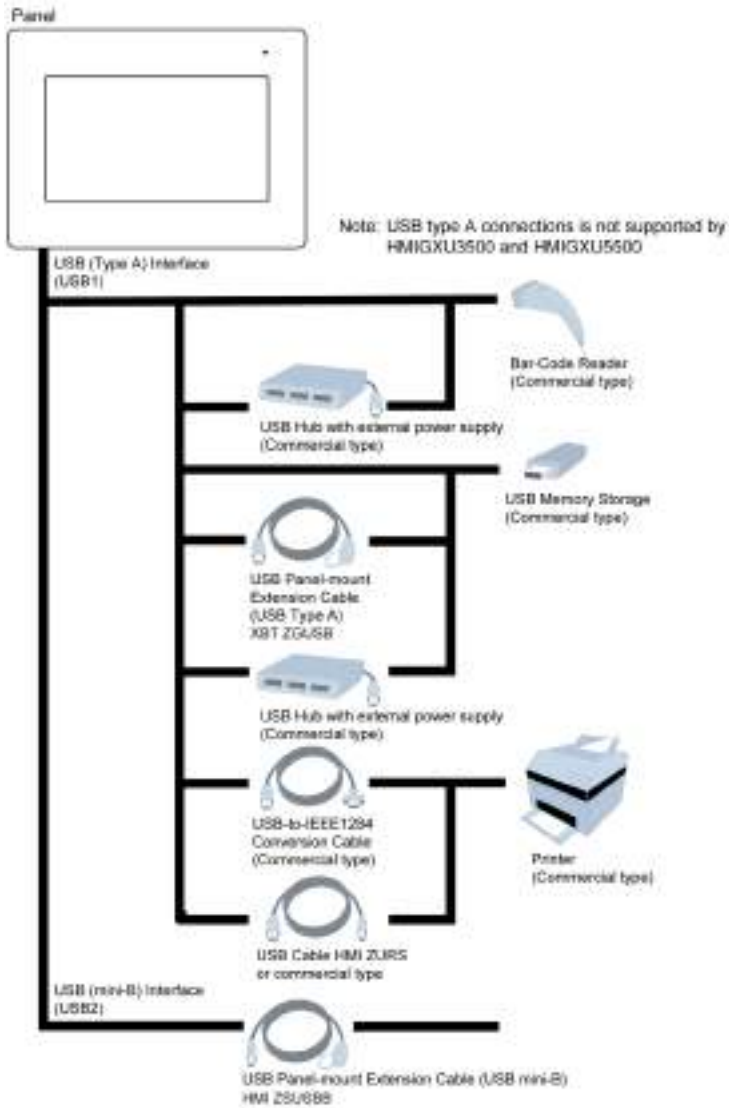

Run Mode Peripherals - Serial Communication

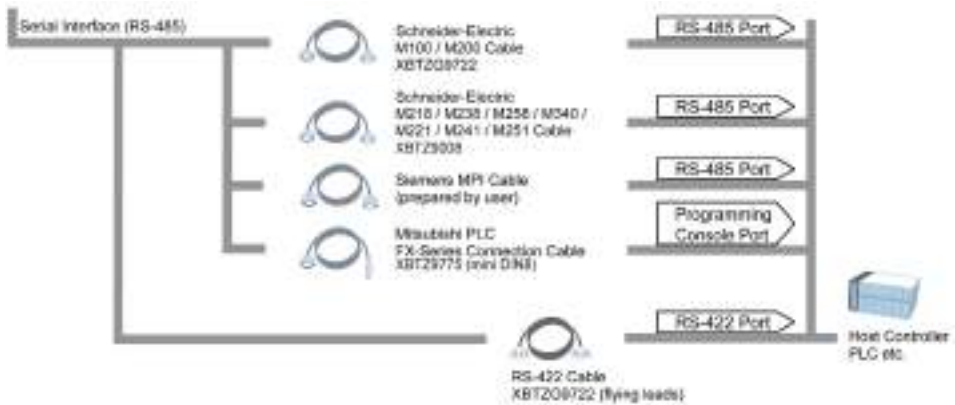
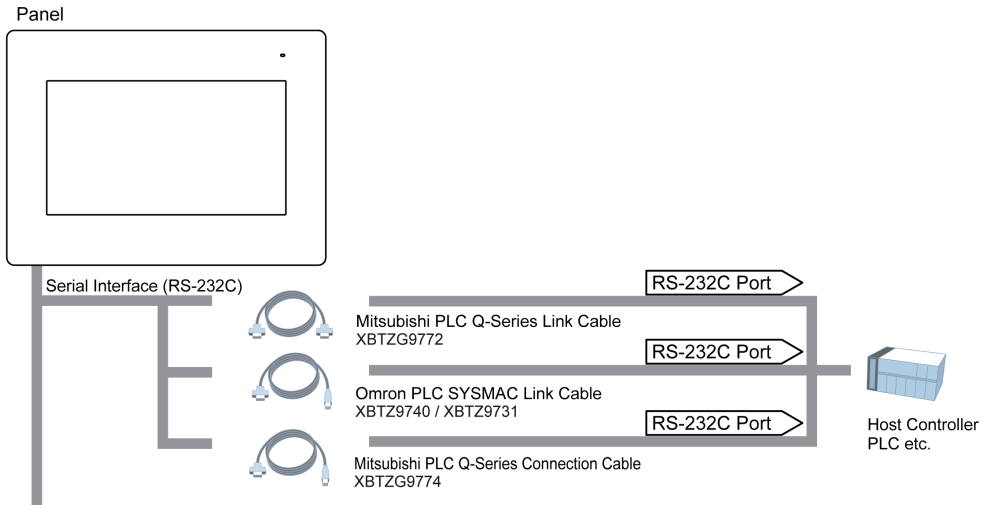

Accessories

Serial Interface Items

Product number	Product name	Description
XBTZ9008	Cable	Connects HMIGXU (RS-485) to Modicon M221, M241, M251, M218, M238, M258, M340, or M580
		Connects HMIGXU (RS-485) to ATV drives
XBTZ9018		Connects HMIGXU (RS-485) to Micro, Twido PLC
XBTZG9722	Cable	Connects HMIGXU (RS-422) to RS-422 devices (terminal block)

Product number	Product name	Description	Supplier
XBTZG9772	Cable	Connects HMIGXU (RS-232) to PLC Q series link unit	Mitsubishi
XBTZG9774		Connects HMIGXU (RS-232) to PLC Q series CPU	
XBTZG9775		Connects HMIGXU (RS-422) to PLC FX series CPU	
XBTZG9740 XBTZG9731		Connects HMIGXU (RS-232) to PLC Sysmac link series	Omron

USB Interface Items

Product name	Product number	Description
USB type A panel mount extension cable	XBTZGUSB	Extends a USB1 host interface on a cabinet with waterproofness
USB type A conversion cable	HMIZURS	Converts a USB1 host interface to RS-232
USB type mini B panel mount extension cable	HMIZSUSBB	Extends a USB2 host interface on a cabinet with waterproofness
USB data transfer cable type A / mini B	BMXXCAUSBH018	Connects the panel to a USB terminal port of a PC

Software

Product name	Description
Vijeo Designer Basic	Software used to create HMI unit project data. It is installed in a personal computer.

Maintenance Options

Product name	Product number	Description
Screw installation fastener	HMIZGFIX3	Fasteners to attach the panel to a mounting surface. (4 fasteners/pack, 6 packs/set)
Power supply connector	XBTZGPW1	Connects the power cord to the panel.

Chapter 3

Specifications

Overview

This chapter presents the HMIGXU specifications.

What Is in This Chapter?

This chapter contains the following sections:

Section	Topic	Page
3.1	General Specifications	24
3.2	Functional Specifications	27
3.3	Interface Specifications	30
3.4	Dimensions	41

Section 3.1

General Specifications

Specifications

Specification		Value
Power supply	Rated input voltage	24 Vdc
	Input voltage limits	20.4...28.8 Vdc
	Acceptable voltage drop	≤ 1 ms with lowest input voltage ≤ 10 ms with rated input voltage
	Power consumption	HMIGXU3500: 5.4 W HMIGXU3512: 9.2 W HMIGXU5500: 6.1 W HMIGXU5512: 10 W
	In-rush current	≤ 50 A ¹
	Voltage endurance between power terminal and functional ground (FG)	1000 Vac 5 mA for 1 min
	Insulation resistance between power terminal and FG.	10 MΩ or higher at 500 Vdc
Physical	Ambient operating temperature (cabinet interior and panel face)	0...50 °C (32...122 °F)
	Storage temperature	-20...60 °C (-4...140 °F)
	Relative humidity	90 % non-condensing
	Air purity (dust)	≤ 0.1 mg/m ³ (3.5 ⁻⁶ oz/ft ³) (non-conductive levels)
	Pollution degree	2
	Corrosive gases	Free of corrosive gases
	Atmospheric pressure	800...1,114 hPa (2,000 m (6561 ft) or less)
Mechanical	Vibration immunity	IEC 61131-2 ed.3 (07) 5...150 Hz, 3.5 mm (0.38 in) max., 1 g on 3 axes.
	Shock immunity	IEC 61131-2 ed.3 (07) 1/2 sinusoidal pulse for 11 ms, 15 g on 3 axes
	Cooling method	Natural air circulation
¹ For in-rush current, the FWHM (full-width, half maximum) value is approximately 50 μs (when exceeding 25 A).		

Specification		Value
Structural	Protection (front panel)	IP 65 - (IEC 60529) Enclosure type 4 indoor use only (UL 50) with screw installation fasteners
	Protection (rear panel)	IP 20 - (IEC 60529)
Electrical	Radiated radio frequency electromagnetic field	10 V/m / 80 MHz...1 GHz, 3 V/m / 1.4 MHz...2 GHz, 1 V/m / 2 GHz...3 GHz, sinus amplitude modulated 80 % / 1 kHz and internal clock frequency
	Electrical fast transient	EN/IEC 61131-2 zone B 2 kV power supply and 1 kV shielded cables
	High energy surges	IEC 61000 - 4 - 5 0.5 kV (Differential mode on power supply) 1 kV (Common mode on power supply)
	Electrostatic discharge immunity	EN/IEC 61131-2 4 kV contact, 8 kV air
¹ For in-rush current, the FWHM (full-width, half maximum) value is approximately 50 μ s (when exceeding 25 A).		

The front face of the panel, installed in a solid panel, has been tested using conditions equivalent to the standards shown in the specification.

CAUTION

EQUIPMENT DAMAGE

Ensure that the panel is not in permanent and direct contact with oils.

Failure to follow these instructions can result in injury or equipment damage.

NOTICE

STORAGE AND OPERATION OUTSIDE OF SPECIFICATIONS

- Store this product in areas where temperatures are within the product's specifications.
- Do not restrict or block this product's ventilation slots.

Failure to follow these instructions can result in equipment damage.

NOTICE

GASKET AGING

- Inspect the gasket periodically as required by your operating environment to keep the initial IP level.
- Change the gasket at least once a year, or as soon as scratches or dirt become visible.

Failure to follow these instructions can result in equipment damage.

Air Quality Requirements

Do not operate or store the panel where any of the following chemicals may evaporate or where these chemicals are present in the air:

- Corrosive chemicals such as acids, alkalines, and liquids containing salt.
- Flammable chemicals such as organic solvents.

CAUTION

INOPERATIVE EQUIPMENT

Do not allow water, liquids, metal, and wiring fragments to enter the panel case.

Failure to follow these instructions can result in injury or equipment damage.

Section 3.2

Functional Specifications

Overview

This section presents the HMIGXU functional specifications of the display, memory, and interfaces.

What Is in This Section?

This section contains the following topics:

Topic	Page
Display Specifications	28
Memory, Clock, and Touch Panel	29

Display Specifications

Displays

Specification	HMIGXU35**	HMIGXU55**
Type	TFT color LCD	
Resolution (pixels)	800 x 480 (WVGA)	800 x 480 (WVGA)
Active display area (W x H)	154.08 x 85.92 mm (6.066 x 3.382 in.)	219.6 x 131.76 mm (8.645 x 5.187 in.)
Colors	65,536 colors	
Backlight service life	20,000 hours or more (continuous operation at 25 °C (77 °F) before backlight brightness decreases to 50 %) NOTE: To save the life of the backlight, set the panel in standby mode which automatically turns off the backlight when no touch input is detected within a set time.	
Brightness	16 levels available through the touch panel	
System embedded language fonts ⁽¹⁾	ASCII: (code page 850) alphanumeric (including European characters) Chinese (simplified): GB2312-80 codes Chinese (traditional): large 5 codes	
Character sizes ⁽¹⁾	8 x 8, 8 x 16, 16 x 16, and 32 x 32 pixel fonts	
Font sizes	Width can be expanded 1, 2, 4, and 8 times. Height can be expanded 1/2, 1, 2, 4, and 8 times.	
8 x 8 pixels	40 characters per row x 30 rows	
8 x 16 pixels	40 characters per row x 15 rows	
16 x 16 pixels	20 characters per row x 15 rows	
32 x 32 pixels	10 characters per row x 7 rows	

NOTE: (1) The display font differs depending on the selected (language) character or size. Also, if Vijeo Designer Basic software is used, additional high-quality fonts are available with 16 x 16 or larger characters.

Memory, Clock, and Touch Panel

Memory

This table describes the memory parameters:

Memory	HMIGXU3500	HMIGXU3512	HMIGXU5500	HMIGXU5512
NAND flash	128 MB	128 MB	128 MB	128 MB
User application	32 MB	48 MB	32 MB	48 MB
Backup memory	128 KB	128 KB	128 KB	128 KB
Main memory DDR	128 MB	128 MB	128 MB	128 MB

Clock

Variations in operating conditions and battery life can cause a clock inaccuracy from -60 seconds to +60 seconds per month.

Monitor and adjust the time as needed to satisfy the system requirements. For time-dependent applications, refer to the Vijeo Designer Basic Help for information on synchronizing the panel clock with the PLC clock. To preserve processing time, do not synchronize continually. You can synchronize the clocks approximately twice a day.

Touch Panel

Specification	HMIGXU series
Service life	1 million switch and 100 thousand slide operations

Section 3.3

Interface Specifications

Overview

This section presents the interface specifications of the panels.

What Is in This Section?

This section contains the following topics:

Topic	Page
Interface Specifications	31
Serial Interface Specifications RS-232C	33
Serial Interface Specifications RS-422/485	35
USB Port	37
Ethernet Port	39

Interface Specifications

Introduction

All HMIGXU panels are provided with serial and USB interfaces.

Serial Interface RS-232C

This table describes the RS-232C serial interface:

Interface	Description
Serial interface D-Sub9	
Asynchronous transmission	RS-232C
Data length	7 bits or 8 bits
Stop bit	1 bits or 2 bits
Parity	None, odd or even
Data transmission speed	2,400...115,200 bps

Serial Interface RS-422/485

This table describes the RS-422/485 serial interface:

Interface	Description
Serial interface D-Sub9	
Asynchronous transmission	RS-422/485
Data length	7 bits or 8 bits
Stop bit	1 bits or 2 bits
Parity	None, odd or even
Data transmission speed	2,400...115,200 bps

USB Interface (USB Peripherals)

This table describes the USB type A interface:

Interface	Description
Host interface	
Maximum current supplied	500 mA
Maximum transmission distance	3 m (9.84 ft) at 1.5/12/480 Mbps
Connector	USB type A V2.0

USB Interface (Application Download)

This table describes the USB mini_B interface:

Interface	Description
USB interface is used for application download	
Maximum transmission distance	3 m (9.84 ft) at 12 Mbps, not long term connects
Connector	USB mini-B V2.0
Isolated	None

Serial Interface Specifications RS-232C

Introduction

This interface is used to connect HMIGXU series to remote equipment, via a RS-232C cable. The connector used is a D-Sub 9-pin male connector.

By using a long PLC cable to connect to the panel, it is possible that the cable can be at a different electrical potential than the panel, even if both are grounded.

The serial port of the panel is not isolated. The SG (signal ground) and the FG (functional ground) terminals are separated inside the panel.

DANGER

ELECTRIC SHOCK

- Make a direct connection between the functional ground (FG) terminal and ground.
- Do not connect other devices to ground through the functional ground (FG) terminal of this device.
- Install all cables according to local codes and requirements. If local codes do not require grounding, follow a reliable guide such as the US National Electrical Code, Article 800.

Failure to follow these instructions will result in death or serious injury.

Serial Interface RS-232C

This table describes the COM1 of HMIGXU3512/HMIGXU5512 with a D-Sub 9-pin connector via a RS-232C cable.

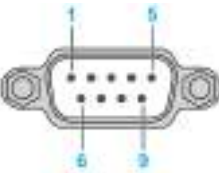
Pin connection	Pin	Signal name	Meaning
	1	CD	Carrier Detect
	2	RD(RXD)	Receive Data
	3	SD(TXD)	Send Data
	4	ER(DTR)	Data Terminal Ready
	5	SG	Signal Ground
	6	DR(DSR)	Data Set Ready
	7	RS(RTS)	Request to Send
	8	CS(CTS)	Send possible
	9	Reserved	–
	Shell	FG	Functional Ground

Any excessive weight or stress on communication cables disconnect communication with the equipment.

 CAUTION

LOSS OF POWER

- Make sure all connections to the communication ports on the bottom and sides of the panel do not put excessive stress on the ports.
- Securely attach communication cables to the panel or cabinet.
- Use only D-Sub 9-pin cables with a locking system in good condition.

Failure to follow these instructions can result in injury or equipment damage.

Serial Interface Specifications RS-422/485

Introduction

This interface is used to connect the HMIGXU series to the remote equipment, via an RS-422/485 cable. The connector used is a D-Sub 9-pin male connector.

By using a long PLC cable to connect to the panel, it is possible that the cable can be at a different electrical potential than the panel, even if both are grounded.

The serial port of the panel is not isolated. The SG (signal ground) and the FG (functional ground) terminals are separated inside the panel.

DANGER

ELECTRIC SHOCK

- Make a direct connection between the functional ground (FG) terminal and ground.
- Do not connect other devices to ground through the functional ground (FG) terminal of this device.
- Install all cables according to local codes and requirements. If local codes do not require grounding, follow a reliable guide such as the US National Electrical Code, Article 800.

Failure to follow these instructions will result in death or serious injury.

Serial Interface RS-422/485

This table describes the COM1 of HMIGXU3500/HMIGXU5500 and COM2 of HMIGXU3512/HMIGXU5512 with a D-Sub 9-pin connector via an RS-422/485 cable.

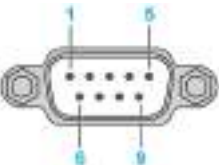
Pin connection	Pin	Signal name	Meaning
	1	RDA	Receive Data A (+)
	2	RDB	Receive Data B (-)
	3	SDA	Send Data A (+)
	4	–	
	5	SG	Signal Ground
	6	–	
	7	SDB	Send Data B (-)
	8	–	
	9	–	
	Shell	FG	Functional Ground

Any excessive weight or stress on communication cables may disconnect communication with the equipment.

 CAUTION

LOSS OF POWER

- Make sure all connections to the communication ports on the bottom and sides of the panel do not put excessive stress on the ports.
- Securely attach communication cables to the panel or cabinet.
- Use only D-Sub 9-pin cables with a locking system in good condition.

Failure to follow these instructions can result in injury or equipment damage.

USB Port

Introduction

The following panels have a USB type A port:

- HMIGXU3512
- HMIGXU5512

The following panels have a USB type mini B port:

- HMIGXU35**
- HMIGXU55**

You can connect the data transfer cable (BMXXCAUSBH018) to the USB port to transfer data from the computer to the panel.

Follow the procedure described below to prevent damage to the cable connector or panel.

- Do not connect the USB data transfer cable until specified to do so in the instructions.
- When connecting the USB data transfer cable to the computer or to the panel, insert the cable connector at the correct 90° angle.
- When disconnecting the cable, make sure to hold the connector, not the cable itself.
- If the cable is unplugged from the port during installation and connected to a different port, the operating system will not recognize the new port. Therefore, make sure to always use the designated port.
- If the installation does not complete successfully, restart the computer and quit all resident applications before reinstalling the software.

USB Data Transfer

Perform this check after installation:

Step	Action
1	On the target machine, make sure that the USB cable is physically connected to the USB port.
2	On the PC, make sure that the USB cable is physically connected to the USB port.
3	On the desktop, right-click My Computer and click Properties .
4	In the System Properties dialog box, select the Hardware tab, and then click Device Manager .
5	In the Device Manager , the USB link cable (BMXXCAUSBH018) should display below the USB controller.

Troubleshooting

Symptom	Solution
The USB cable is not recognized.	Connect the cable correctly, or restart your PC. Also, when connecting a USB hub, make sure to connect it directly to your PC's USB port.
Overcurrent occurred	
The plug and play is not functioning correctly.	
You are unable to use the USB cable after connecting it to a USB hub.	The power supplied from the hub may be insufficient. Make sure that the hub is self-powered.
	Connect the cable directly to the PC USB port.
After installation, a ? is displayed when you try to confirm the cable status via the Device Manager .	The driver has not been installed correctly. Uninstall the driver and reinstall it.

Ethernet Port

Introduction

The HMIGXU3512 and HMIGXU5512 are equipped with an IEEE802.3 compliant Ethernet communication port that transmits and receives data at 10 Mbps or 100 Mbps.

NOTE: Ethernet networks must be installed by a trained and qualified person.

NOTE: One to one (1:1) connections must be made with a hub or a switch. You can use the 1:1 connection with a cross cable depending on the connected PCs and network cards.

Characteristics

The table describes the different Ethernet characteristics:

Characteristics	Description
Connector type	RJ45
Driver	<ul style="list-style-type: none">● 10 M half duplex (auto negotiation)● 100 M full duplex (auto negotiation)
Cable type	Shielded
Automatic cross-over detection	Yes

Pin Assignment

The figure shows the RJ45 Ethernet connector pin assignment:

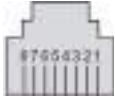

The table describes the RJ45 Ethernet connector pins:

Pin	Signal
1	TD+
2	TD-
3	RD+
4	–
5	–
6	RD-
7	–
8	–

NOTE: The HMIGXU3512 and HMIGXU5512 supports the MDI/MDIX auto-crossover cable function. You do not have to use special Ethernet crossover cables to connect devices directly to this port (connections without an Ethernet hub or switch).

Status LEDs

The figure shows the LEDs of the Ethernet connector:

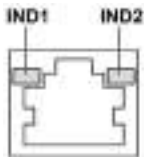

The table describes the Ethernet status LEDs operation:

Label	Description	LED		
		Color	Status	Description
IND1	Ethernet status	Green	Off	No connection or subsequent transmission failure.
			On	Data transmission is available.
IND2	Ethernet activity	Green	Off	No data transmission.
			On	Data transmission is occurring.

Section 3.4

Dimensions

Overview

This section presents the dimensions of HMIGXU panels.

What Is in This Section?

This section contains the following topics:

Topic	Page
HMIGXU35•• Dimensions	42
HMIGXU55•• Dimensions	43
Panel-cut Dimensions	45
Installation Fasteners	46

HMIGXU35 Dimensions

Panel Dimensions

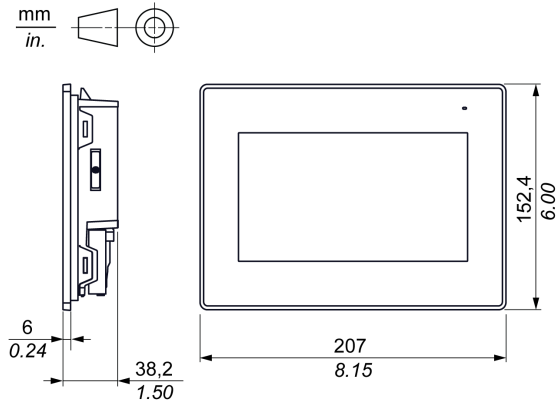

Dimensions with Cables

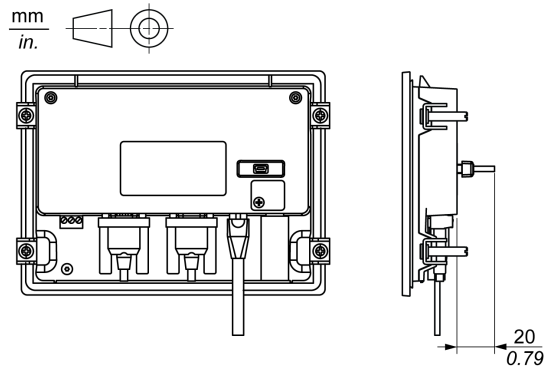

Dimensions with Installation Fasteners

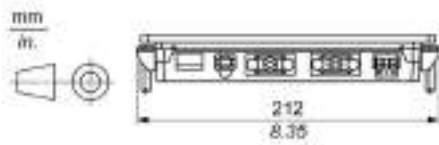

HMIGXU55•• Dimensions

Panel Dimensions

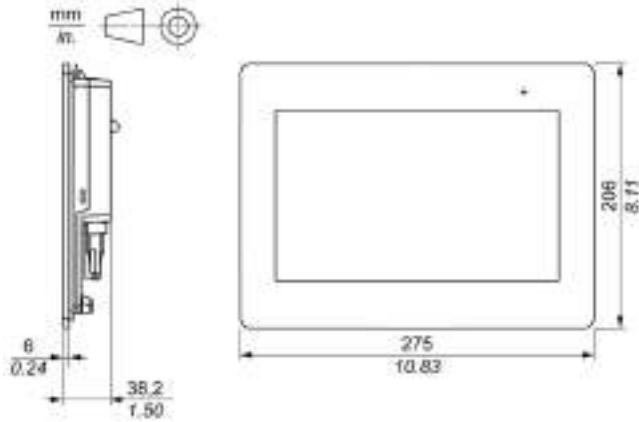

Dimensions with Cables

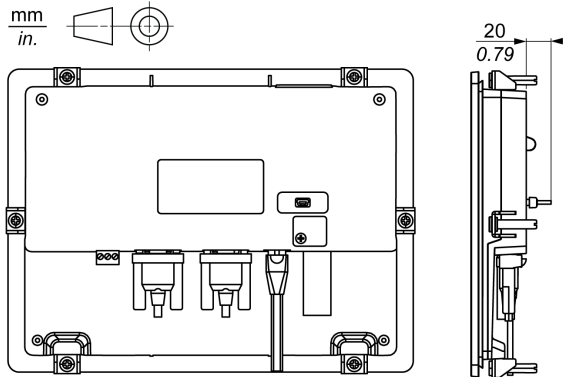

Dimensions with Installation Fasteners

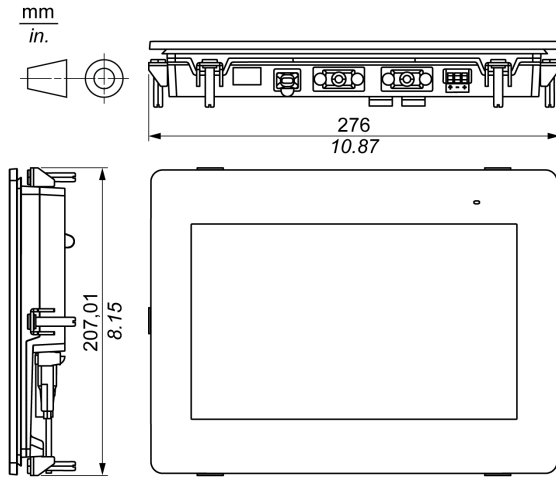

Panel-cut Dimensions

Inserting a HMIGXU

Create a panel-cut and insert the panel from the front. This figure shows the panel-cut for the HMIGXU series:

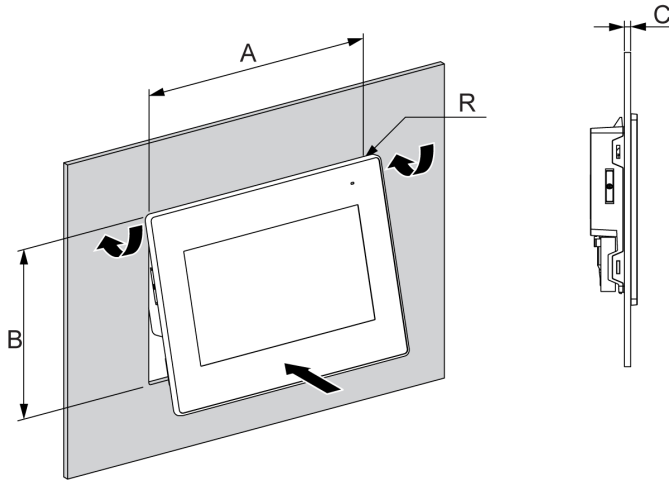

Dimensions

The following table shows the panel-cut dimensions for each panel:

Model	A	B	C (Panel thickness)	R
HMIGXU35**	190 ^{±1} mm (7.48 ^{±0.04} in)	135 ^{±0.7} mm (5.31 ^{±0.03} in)	1...5 mm (0.04...0.19 in)	3 mm (0.12 in) max.
HMIGXU55**	255 ^{±1} mm (10.04 ^{±0.04} in)	185 ⁺¹ mm (7.28 ^{+0.04} in)	1...5 mm (0.04...0.19 in)	3 mm (0.12 in) max.

Installation Fasteners

Introduction

The fasteners are used to mount the HMIGXU series:

Model	Screw installation fasteners
HMIGXU35**	4
HMIGXU55**	6

Dimensions

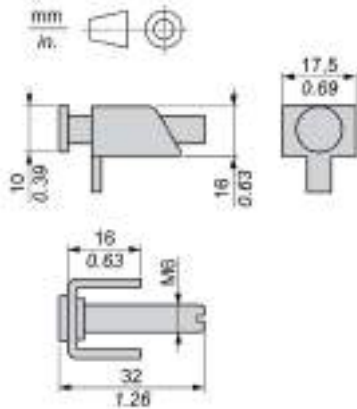

Chapter 4

Installation and Wiring

Overview

This chapter describes the installation procedures and wiring principles for HMIGXU.

What Is in This Chapter?

This chapter contains the following sections:

Section	Topic	Page
4.1	Installation	48
4.2	Wiring Principles	55
4.3	USB Port	62

Section 4.1

Installation

Overview

This section describes the installation procedures for HMIGXU.

What Is in This Section?

This section contains the following topics:

Topic	Page
Installation Procedures	49
Real Time Clock (RTC)	53

Installation Procedures

Introduction

The installation gasket and screw fasteners are required when installing the panel.

Mount the panel in an enclosure that provides a clean, dry, robust, and controlled environment (IP65 enclosure).

NOTE: The protection level of the product may vary from that which is shown on the label, as the value on the label considers product aging.

An old gasket can lose its dust and drip resistance. Changing the gasket once a year or when scratches or dirt becomes visible is recommended.

Gasket Setup Requirements

The gasket helps to maintain the protection ratings (IP65, IP20) of the panel, and provides additional protection from vibration.

Stage	Description
1	Before installing the panel into a cabinet, check that the installation gasket is securely attached to the panel.
2	A gasket which has been used for a long period may have scratches or dirt on its surface, and could have lost much of its dust and drip resistance. Change the gasket once a year or when scratches or dirt become visible.
3	Make sure that the gasket is inserted into the bottom face of the panel.

Panel Setup Procedure

Stage	Description
1	Check that the installation panel or the surface of the cabinet is flat, in good condition and has no jagged edges. Metal reinforcing strips may be attached to the inside of the panel wall, near the panel-cut, to increase the rigidity of the panel.
2	Decide on the installation of the thickness of the panel based on the level of panel strength required: 1 mm (0.04 in) to 5 mm (0.19 in).
3	Be sure that the ambient operation temperature and the ambient humidity are within their designated ranges. (When installing the panel in a cabinet or enclosure, the ambient operation temperature is the internal temperature of the cabinet or enclosure.)
4	Be sure that heat from surrounding equipment does not cause the panel to exceed its standard operating temperature (see page 24).

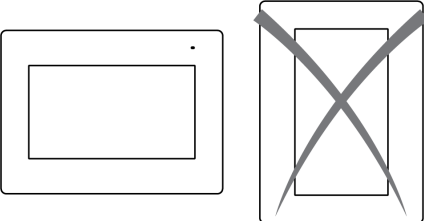
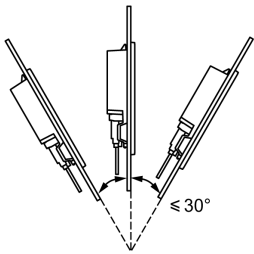
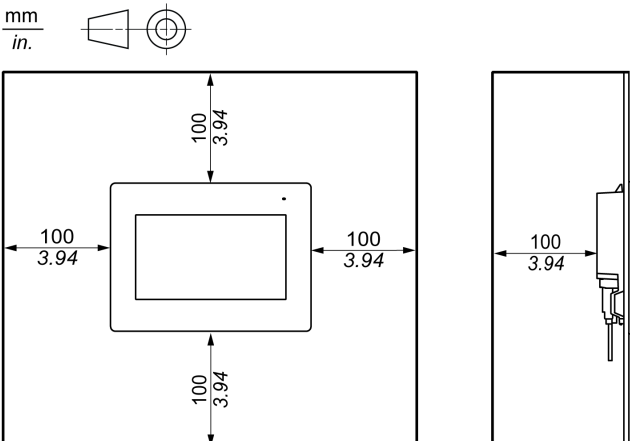
Stage	Description
4	<p>The panel is designed to be ready for landscape only in the cabinet.:</p> 
5	<p>When installing the panel in a slanted position, the panel face should not incline more than 30° :</p>  <p>When installing the panel in a slanted position, and the panel face inclines more than 30°, the ambient temperature must not exceed 40 °C (104 °F). You may need to use forced air cooling (fan, A/C) to ensure that the ambient operating temperature is 40 °C or below.</p>
6	<p>For easier maintenance, operation and improved ventilation, install the panel at least 100 mm (3.94 in) away from adjacent structures and other equipment:</p> 

Panel Mounting Procedure

NOTICE

PANEL UNSTEADY WHEN UNSECURED

Keep panel stabilized in the panel-cut while you are installing or removing the screw fasteners.
Failure to follow these instructions can result in equipment damage.

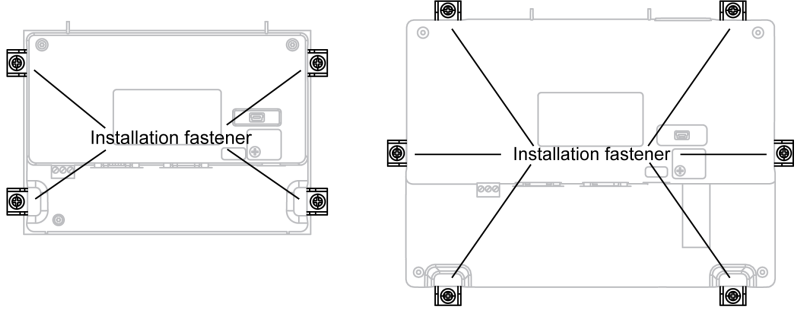
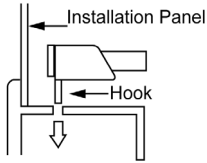
Step	Action
1	Place the panel on a clean and level surface with the display face pointing downward.
2	Check that the installation gasket of the panel is seated securely, which runs around the perimeter of the frame.
3	Create the correct sized opening required to install the panel, using the installation dimensions (see page 41).
4	Insert the panel into the panel-cut.
5	Insert the installation fasteners into the panel's insertion slots on the left and right sides (and on the top and bottom sides of the HMIGXU55**):
	
6	Slide the fasteners flat against the panel. If the fasteners are not correctly attached, the panel may shift or fall out:
	

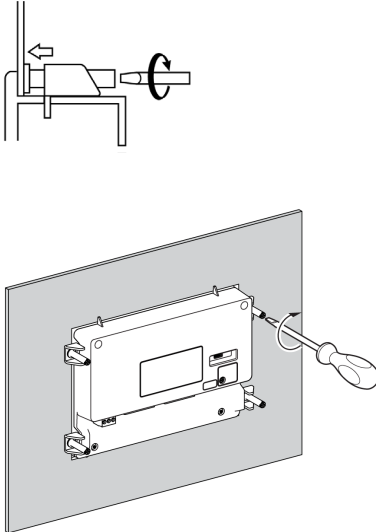
Step	Action
7	<p data-bbox="322 203 1218 251">Use a Phillips screwdriver to tighten each fastener and secure the panel in place. The necessary torque is 0.8 Nm (7.08 lb-in) maximum:</p> 

NOTICE

BROKEN ENCLOSURE

Do not exert more than 1 Nm (8.85 lb-in) of torque when tightening the fastener's screws.

Failure to follow these instructions can result in equipment damage.

Real Time Clock (RTC)

Overview

HMIGXU panels include an RTC to provide system date and time information, and to support related functions requiring a real-time clock. To keep time continuity when power is off, a non-rechargeable but replaceable battery is provided with HMIGXU panels.

NOTE: The HMIGXU panels cannot sustain the time when exchanging RTC battery without power connected.

Installing and Replacing the RTC Battery

While lithium batteries are preferred due to their slow discharge and long life, they can present hazards to personnel, equipment, and the environment, and must be handled properly.

 DANGER

EXPLOSION, FIRE, OR CHEMICAL HAZARD

Follow these instructions for the lithium batteries:

- Replace with identical type.
- Follow all battery manufacturer's instructions.
- Remove all replaceable batteries before discarding panel.
- Recycle or properly dispose of used batteries.
- Protect battery from any potential short circuit.
- Do not recharge, disassemble, heat above 100 °C (212 °F), or incinerate.
- Use your hands or insulated tools to remove or replace the battery.
- Maintain proper polarity when inserting and connecting a new battery.

Failure to follow these instructions will result in death or serious injury.

NOTE: Replace battery only with identical type: Type BR2032.

To install or replace the RTC battery, follow these steps:

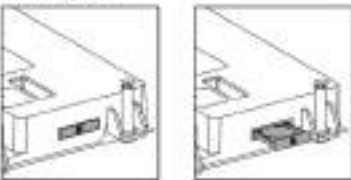
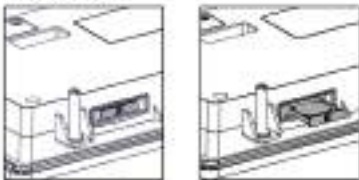
Step	Action
1	Power off your panel.
2	Open the cap to access the backup battery compartment as shown: <div style="display: flex; justify-content: space-around; align-items: center; margin-top: 10px;"> <div style="text-align: center;"> <p>HMIGXU35●●</p>  </div> <div style="text-align: center;"> <p>HMIGXU55●●</p>  </div> </div>
3	Remove the used battery from the compartment.
4	Insert the new battery in the compartment in accordance with the polarity markings in the compartment and on the battery.
5	Close the cap.
6	Power up your HMIGXU. NOTE: If you do not power up your HMIGXU immediately, the external backup battery life might be reduced.
7	Set the internal clock. For further details on the internal clock, refer to set terminal clock (see Vijeo-Designer online Help).
A lithium battery life is: <ul style="list-style-type: none"> ● 3 years when the battery's ambient temperature is $\leq 40\text{ }^{\circ}\text{C}$ ($104\text{ }^{\circ}\text{F}$). ● 3 years when the panel's ambient temperature is $\leq 25\text{ }^{\circ}\text{C}$ ($77\text{ }^{\circ}\text{F}$). 	

Section 4.2

Wiring Principles

Overview

This section presents HMIGXU wiring principles.

What Is in This Section?

This section contains the following topics:

Topic	Page
Connecting the Power Cord	56
Connecting the Power Supply	58
Grounding	60

Connecting the Power Cord

Introduction

Follow these instructions when supplying power to the panel.

- When the functional ground (FG) terminal is connected, be sure that the wire is grounded. If not grounded, the panel can result in excessive Electromagnetic Interference (EMI). Grounding is required to meet EMC level immunity.
- The shield ground (SG) and FG terminals are connected internally in the panel.
- Disconnect the power before wiring the panel's power terminals.
- The panel uses only 24 Vdc power. Using any other level of power can damage both the power supply and the panel.
- Since the panel is not equipped with a power switch, be sure to connect a power switch to the panel's power supply.
- Be sure to ground the panel's FG terminal.

Power Cord Preparation

- Make sure that the ground wire is either the same or heavier gauge than the power wires.
- Do not use aluminum wires in the power supply's power cord.
- If the ends of the individual wires are not twisted correctly, the wires may create a short circuit. To avoid this, use D25CE/AZ5CE cable ends.
- Wherever possible, use wires that are 0.75 to 2.5 mm^2 (AWG 18 - 12) for the power cord, and twist the wire ends before attaching the terminals.
- The conductor type is solid or stranded wire.

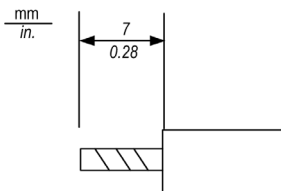

Power Plug Description

Pin connection	Pin	Wire
	+	24 Vdc
	-	0 Vdc
	FG	Grounded terminal connected to the panel chassis.

How to Connect the Power Cord

This figure shows a connection of the power cord:

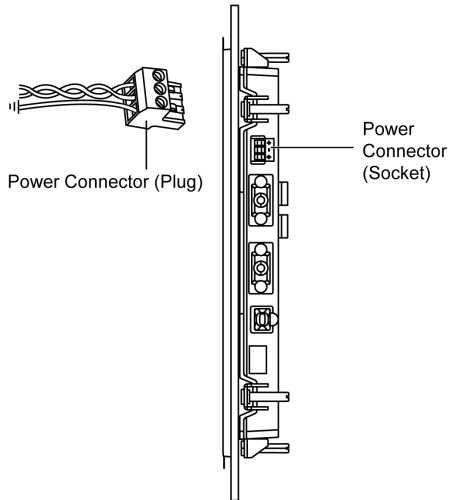

This table explains how to connect the power plug:

Step	Action
1	Remove the power cord from the power supply.
2	Remove the power plug from the panel.
3	Remove 7 mm (0.28 in.) of the vinyl cover off the ends of the power cord wires.
4	If using stranded wire, twist the ends. Tinning the ends with solder reduces risk of fraying and ensures good electrical transfer.
5	Connect the wires to the power plug by using a flat-bladed screwdriver (size 0.6 X 3.5).
6	Tighten the mounting screws using the defined torque: 0.5...0.6 Nm (5...7 lb-in).
7	Replace the power plug with the power connector.

NOTE:

- Do not solder the wire directly to the power receptacle pin.
- The power supply cord should meet the specification mentioned above. Be sure to twist the power cords together, up to the power plug, for EMC cancellation.

Connecting the Power Supply

Precautions

- Connect the power cord to the power connector on the side of the panel using the power plug.
- Between the line and the ground, be sure to use a regulated power supply with a Class 2 power supply.
- To increase the electromagnetic noise resistance, be sure to twist the ends of the power cord wires before connecting them to the power plug.
- The power supply cord of the panel should not be bundled with or kept close to main circuit lines (high voltage, high current), or input/output signal lines.
- Connect a lightning surge absorber to handle power surges.
- To reduce electromagnetic noise, make the power cord as short as possible.

Excessive stress on the power connection or attempting to install a panel with the power cables connected may disconnect or cause damage to the power connections, which can cause short circuits, fire or unintended equipment operation.

WARNING

SHORT CIRCUITS, FIRE, OR UNINTENDED EQUIPMENT OPERATION

Avoid twisting the individual wires incorrectly:

- Use D25CE/AZ5CE cable ends.

Avoid excessive force on the power cable to prevent accidental disconnection:

- Securely attach power cables to the panel or cabinet.
- Use the torque less than 0.5 Nm (4.4 lb-in) to tighten the terminal block screws of the panel.
- Install and fasten panel on installation panel or cabinet before connecting power supply and communication lines.

Failure to follow these instructions can result in death, serious injury, or equipment damage.

Power Supply Connections

For ease of maintenance, use the following connection diagram to set up your power supply connections.

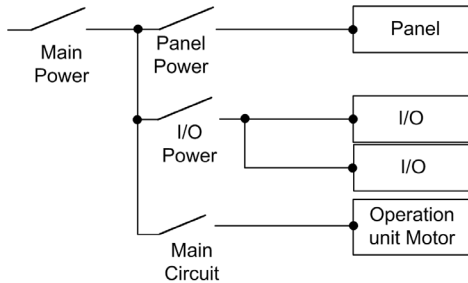

NOTE:

- Ground the surge absorber (E1) separately from the panel (E2).
- Select a surge absorber that has a maximum circuit voltage greater than that of the peak voltage of the power supply.

The following shows a lightning surge absorber connection:

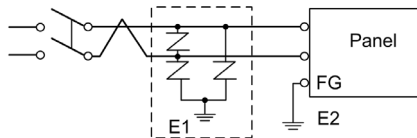

Grounding

Exclusive Grounding

Take the following precautions for grounding the panel. Connect the functional ground (FG) terminal on the power plug to an exclusive ground.

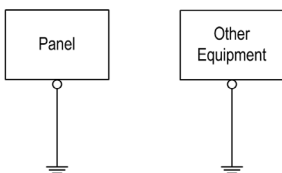

Grounding Procedure

Step	Action
1	Check that the grounding resistance is less than 0.1Ω ⁽¹⁾ .
2	The FG wire should have a cross sectional area greater than 2 mm^2 ⁽¹⁾ . Create the connection point as close to the panel as possible, and make the wire as short as possible. When using a long grounding wire, replace the thin wire with a thicker wire, and place it in a duct.
3	If the equipment does not function properly when grounded, disconnect the ground wire from the FG terminal.
⁽¹⁾ Observe local codes and standards. Ensure that the ground connection has a resistance of less than 0.1Ω and that the ground wire has a cross-section of at least 2 mm^2 or AWG 14.	

Common Grounding

Take the following precautions for grounding the panel.

Electromagnetic Interference (EMI) can be created if the devices are improperly grounded. EMI can cause loss of communication.

Do not use common grounding, except for the authorized configuration described below.

If exclusive grounding is not possible, use a common connection point.

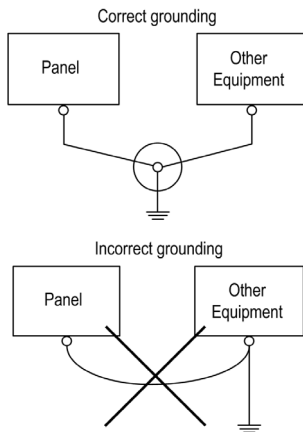

Section 4.3

USB Port

USB Type A Installation

Introduction

When using a USB device, locking the USB interface with the panel helps prevent the USB cable from being disconnected.

The USB locker does not work with the slim type USB memory stick.

Locking the USB

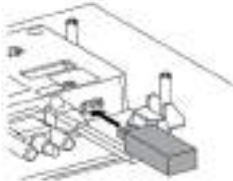
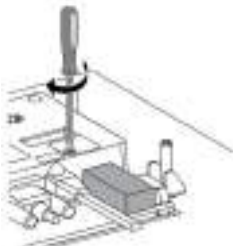
Step	Action
1	Insert the USB cable into the USB host interface: 
2	Lock the USB using a screw driver, torque is 0.5...0.8 Nm (4.42...7.07 lb-in): 

Releasing the USB

Unlock the USB and then remove the USB memory key.

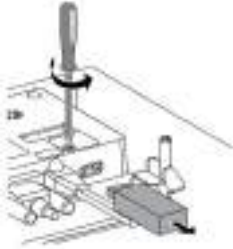

Chapter 5

Maintenance

Overview

This chapter explains how to maintain your HMIGXU.

What Is in This Chapter?

This chapter contains the following topics:

Topic	Page
Precaution	66
Periodic Check Points	67
Regular Cleaning	68

Precaution

Precaution for Long and Safe Use Without Any Breakdowns



Operating the screen with sharp objects may result in damage to the front sheet or the touch panel, and cause abnormal operation. (A switch in a different location from the one you touched may be activated.)



Dropping this product or impacting the screen with excessive pressure may result in breakage of the glass of the touch panel or liquid crystal display. In addition, when mounting this product with the installation fasteners, applying force exceeding the appropriate torque specified in the manual may result in breakage of the front panel.



Using HMI in sunlight or ultraviolet light may shorten the lifetime of the touch panel and may cause the failure of touch functions.



Cleaning the product with chemical agents or allowing penetration of liquids into the product may cause abnormal operation or breakdowns.

NOTICE

EQUIPMENT DAMAGE

- Power off the unit before cleaning it.
- Do not touch the screen with sharp objects when operating this product.
- Do not touch the screen with excessive pressure when operating this product.
- Avoid using HMI in sunlight or ultraviolet light.
- Avoid using chemical agents or allowing liquids to get into this product.

Failure to follow these instructions can result in equipment damage.

Periodic Check Points

Operation Environment

- The operating temperature should be within the allowable range (0...50 °C) (32...122 °F).
- The operating humidity should be within the specified range.
- The operating atmosphere should be free of corrosive gases.

Electrical Specifications

The input voltage should be within 20.4 to 28.8 Vdc.

Related Items

- Are all power cords and cables connected properly? Have any become loose?
- Are all mounting brackets holding the unit securely?
- Are there many scratches or traces of dirt on the installation gasket?

<i>NOTICE</i>
EQUIPMENT DAMAGE <ul style="list-style-type: none">● Do not use hard or pointed objects to operate the touch panel since it can damage the panel surface.● Do not apply excessive pressure to the panel.● Do not expose the panel to direct sunlight/ultraviolet rays.● Do not use paint thinner, organic solvents, or a strong acid compound to clean the unit. Failure to follow these instructions can result in equipment damage.

Regular Cleaning

Cleaning the Display

NOTICE

EQUIPMENT DAMAGE

- Power off the unit before cleaning it.
- Do not use hard or pointed objects to operate the touch panel, since it can damage the panel surface.
- Do not use paint thinner, organic solvents, or a strong acid compound to clean the unit.

Failure to follow these instructions can result in equipment damage.

When the surface or the frame of the display gets dirty, soak a soft cloth in water with a neutral detergent, wring the cloth tightly, and wipe the display.

Do not use paint thinner, organic solvents, or a strong acid compound to clean the unit.

Cleaning the Gasket

The gasket protects the panel and improves its water resistance.

NOTICE

GASKET AGING

- Inspect the gasket periodically as required by your operating environment to keep the initial IP level.
- Change the gasket at least once a year, or as soon as scratches or dirt become visible.

Failure to follow these instructions can result in equipment damage.

During normal maintenance and reinstallation, check the gasket for dirt and scratches.

Inserting the Gasket

Insert the gasket correctly into the groove to comply with IP65.



Symbols

peripherals
 edit mode, 18
 run mode, 19, 20

A

accessories, 21

C

certifications and standards, 13
clock, 29
connecting the power cord, 56
connecting the power supply, 58

D

dimensions, 42, 43

E

edit mode peripherals, 18

F

fasteners, 46

G

grounding, 60

I

installation
 fasteners, 46
 procedures, 49

M

maintenance
 check points, 67
 cleaning, 68
memory, 29

P

panel-cut dimensions, 45
parts identification and functions, 11
power plug description, 56

R

run mode peripherals, 19, 20

S

specifications, 24
 display, 28
 interfaces, 31
 RS-232C, 31, 33
 RS-422/485, 31, 35
 USB, 31

T

touch panel, 29

U

USB
 port, 37
 USB type A
 installation, 62

