

Electromagnetic brake motor

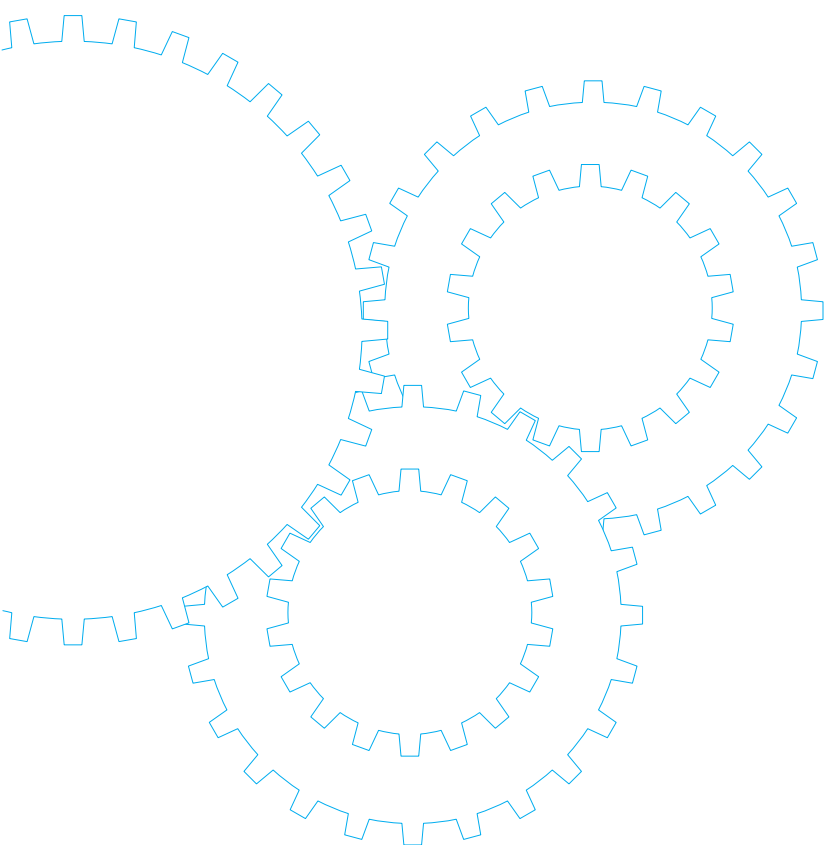

Contents

- Motor Overview B-168
- Model list B-174
- Product information for each model B-178
- Gear head combination dimensions B-218
- Round shaft motor dimensions B-220

Outline of electromagnetic brake motor

Features

- It is suitable for holding the load.
Because the electromagnetic brake is off, when the power is turned off, it will be activated and hold the load securely.
- The brake can be used as an excellent safety brake.
Among the examples are emergency braking at the time of power failure, load holding for a long period of time and the prevention of free-run of the machine.
- The brake will be activated instantly.
The overrun is only 2 to 4 revolutions when the motor is used alone.
- A quick-reversal run can be frequently.
Up to 6 cycles of start/stop can be performed through simple switching. (Secure 3 seconds or longer for a pause.)
If it is necessary that the frequency of reversal operation is 7 to 100 cycles per minute, use the C&B motor. (For running in one direction only)
- Common power for both motor and brake can be used.
Because the electromagnetic brake section contains a rectifier circuit, it can use the same AC power supply as the motor.

Principle of Operation

The construction of the electromagnetic brake motor is shown below. The electromagnetic brake is off. When voltage is applied to the coil, the armature is retracted to the spring. This creates an air gap between the armature and brake lining. The motor shaft is then released from braking to run freely. When the voltage to the coil is shut off (the power is turned off), the armature is pressed against the brake lining by the spring force to stop the motor shaft.

Construction

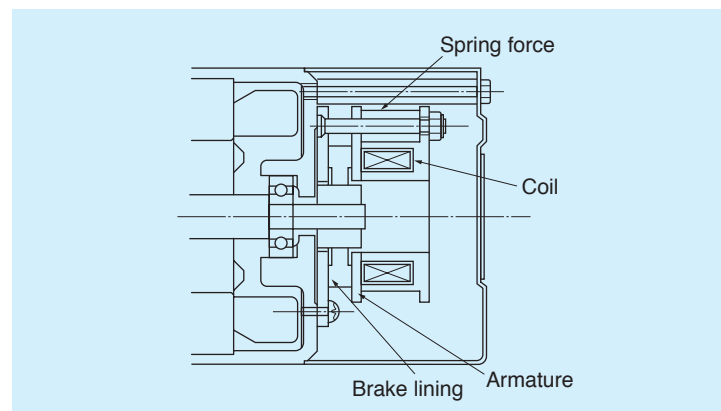

System configuration diagram <In the case of single-phase power supply>

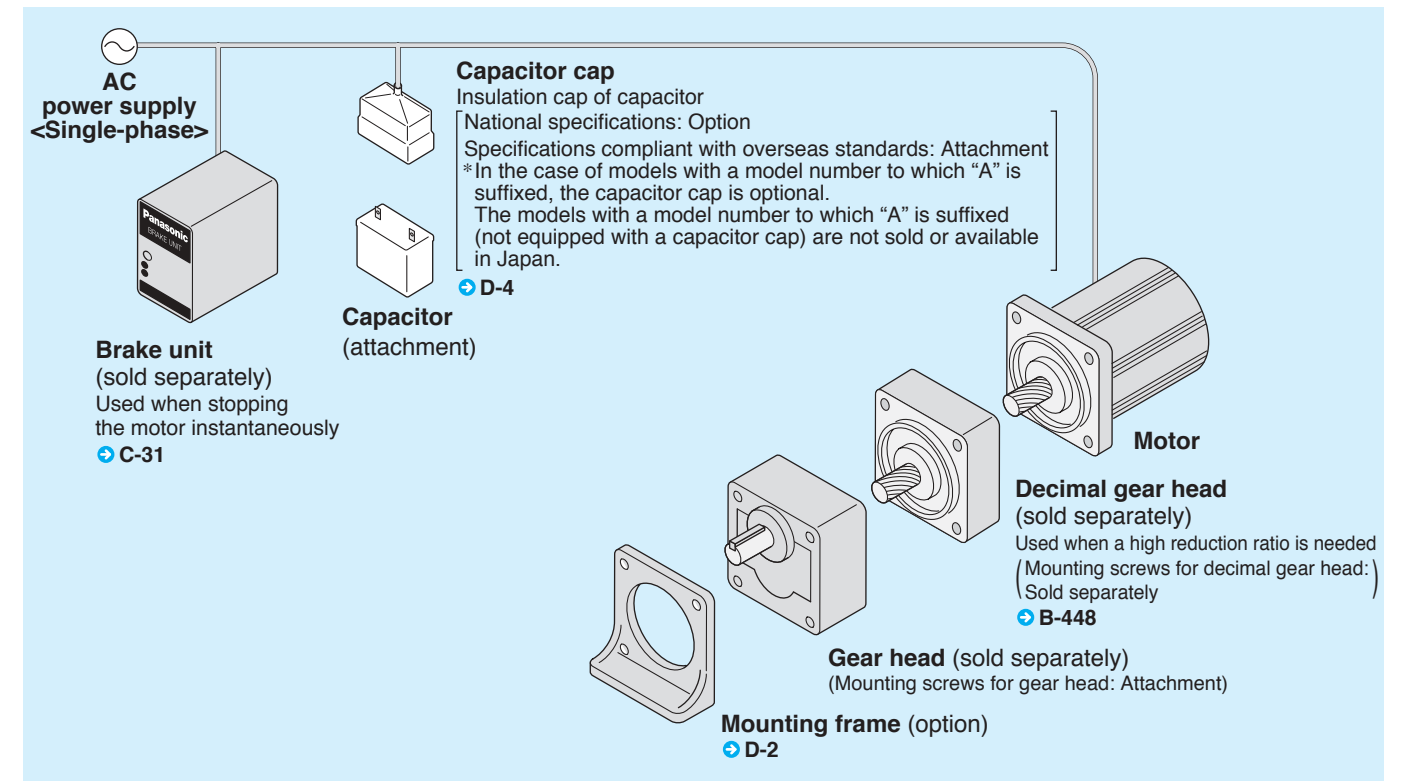

Coding system

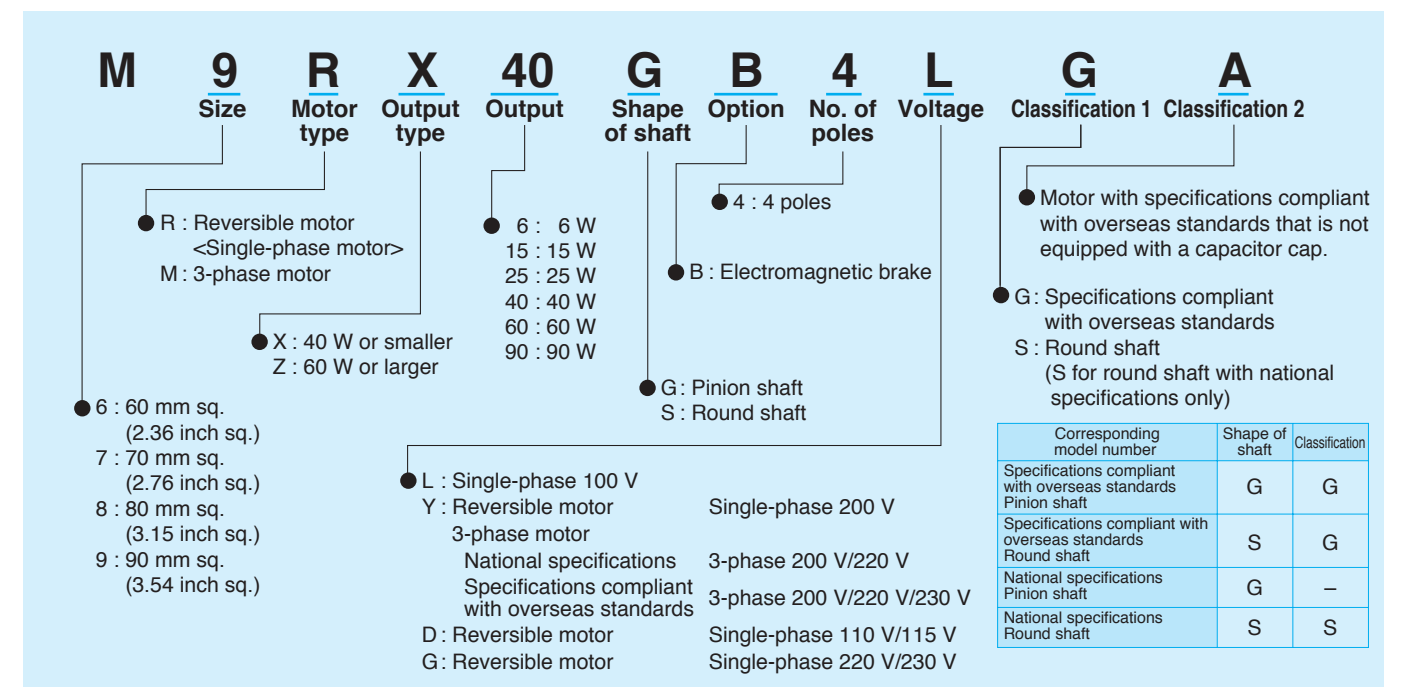

Fit tolerance

Fit tolerance symbol is used in the outside dimension diagram of motor and gear head. For further information, see "Fit tolerance" on page A-33.

Outline of electromagnetic brake motor

Various characteristics of electromagnetic brake motor

The characteristics of the electromagnetic motor include responses regarding a start time, stop time, overrun, etc. And these are all affected by the load inertia.

The characteristics of the electromagnetic motor depend on the following three elements.

- 1) Average acceleration torque of the motor
- 2) Average value of brake torque
- 3) Load torque and inertia

When these elements are identified, the start time and stop time will be determined. It is necessary to give sufficient attention to the load inertia in particular because it varies depending on the equipment used together with the motor. These various characteristics are shown below.

• **Characteristic table** [The brake response characteristics shown below are those obtained when the motor is used alone (load inertia=0).]

No. of phases	Size	Output (W)	Rotor inertia			Brake torque			Frequency (Hz)	Start time (s)	Stop time (s)	Overrun (revolutions)
			J(kg·cm ²)	J (oz-in ²)	GD ² (kgf·cm ²)	N·m	kgf·cm	oz-in				
Single-phase Reversible	60 mm sq. (2.36 inch sq.)	6	0.201	1.099	0.805	0.049	0.5	6.94	50	0.07	0.08	1.5
									60	0.09	0.09	1.6
	70 mm sq. (2.76 inch sq.)	15	0.329	1.799	1.316	0.078	0.8	11.05	50	0.07	0.05	1.5
									60	0.085	0.07	1.5
	80 mm sq. (3.15 inch sq.)	25	0.603	3.299	2.411	0.10	1.0	14.16	50	0.05	0.13	2.2
									60	0.06	0.14	2.3
	90 mm sq. (3.54 inch sq.)	40	1.362	7.447	5.446	0.20	2.0	28.32	50	0.065	0.14	3.0
									60	0.08	0.15	3.5
		60	1.862	10.180	7.447	0.39	4.0	55.23	50	0.055	0.11	2.5
									60	0.065	0.12	2.9
		90	2.353	12.865	9.413	0.39	4.0	55.23	50	0.07	0.13	2.8
									60	0.075	0.14	3.2
3-phase	80 mm sq. (3.15 inch sq.)	25	0.603	3.297	2.411	0.10	1.0	14.16	50	0.05	0.13	2.2
									60	0.06	0.14	2.3
	40	1.362	7.447	5.446	0.20	2.0	28.32	50	0.05	0.15	3.5	
								60	0.06	0.16	4.0	
	60	1.862	10.180	7.447	0.39	4.0	55.23	50	0.06	0.12	3.0	
								60	0.065	0.13	3.4	
	90	2.286	12.499	9.143	0.39	4.0	55.23	50	0.06	0.14	3.3	
								60	0.065	0.15	3.7	

• Inertia

To describe the moment of inertia when handling motors, **J** and **GD²** are used. **J** is generally called Inertia and has the same value as the physical moment of inertia in SI Units. The unit is in [kgf·m²].

GD² is called "Flywheel Effect" and generally used in industrial applications with gravitational systems of units. The unit is in [kgf·m²] or [kgf·cm²]. The relation between **J** and **GD²** is described as follows:

$$J = GD^2 / 4$$

In this catalog, we both use **J** for SI units and **GD²** for gravitational system of units. Unit of **J** should be [kgf·m²] in dynamical significance, however, [kgf·cm²] is used for convenience. Refer to the attached table (page A-48) for calculation of **J** and **GD²** depending on the shape of the load.

Response of electromagnetic brake motor

The following figure shows the start time, stop time and speed variation of the electromagnetic brake motor.

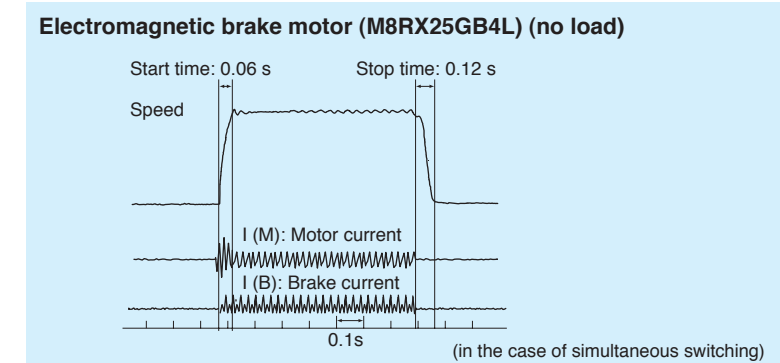

(1) Start time

You can obtain the start time (**ts**) of the motor from the following formula.

• SI units

$$ts = \frac{JM + JL}{9.55 \times 10^4} \times \frac{n}{TA - TL}$$

ts : Start time (s)
TA : Average acceleration torque (N·m)
TL : Load torque (N·m)
JM : Motor inertia (kg·cm²)
JL : Load inertia (kg·cm²)
n : Motor speed (r/min)

• Gravitational system of units

$$ts = \frac{GD^2M + GD^2L}{37500} \times \frac{n}{TA - TL}$$

ts : Start time (s)
TA : Average acceleration torque (kgf·cm)
TL : Load torque (kgf·cm)
GD²M : Rotor GD² (kgf·cm²)
GD²L : Load GD² (kgf·cm²)
n : Motor speed (r/min)

• Average acceleration torque of electromagnetic brake motor

No. of phases	Size	Output (W)	Rotor inertia			Average acceleration torque			Permissible load inertia at motor shaft				
			J (kg·cm ²)	J (oz-in ²)	GD ² (kgf·cm ²)	(N·m)	(oz-in)	(kgf·cm)	J (kg·cm ²)	J (oz-in ²)	GD ² (kgf·cm ²)		
Single-phase Reversible	60 mm sq. (2.36 inch sq.)	6	0.201	1.099	0.805	50 Hz	0.0637	9.02	0.65	0.080	0.437	0.32	
						60 Hz	0.0647	9.16	0.66				
	70 mm sq. (2.76 inch sq.)	15	0.329	1.799	1.316	50 Hz	0.120	16.99	1.22	0.158	0.864	0.63	
						60 Hz	0.114	16.14	1.16				
	80 mm sq. (3.15 inch sq.)	25	0.603	3.299	2.411	50 Hz	0.235	33.28	2.40	0.178	0.973	0.71	
						60 Hz	0.222	31.44	2.27				
	90 mm sq. (3.54 inch sq.)	40	1.362	7.447	5.446	50 Hz	0.439	62.17	4.48	0.735	4.019	2.94	
						60 Hz	0.420	59.48	4.29				
		60	1.862	10.180	7.447	0.39	50 Hz	0.639	90.49	6.52	0.875	4.784	3.50
							60 Hz	0.615	87.09	6.27			
		90	2.353	12.865	9.413	0.39	50 Hz	0.859	121.64	8.76	1	5.468	4.0
							60 Hz	0.804	113.86	8.20			
3-phase	80 mm sq. (3.15 inch sq.)	25	0.603	3.297	2.411	50 Hz	0.388	54.95	3.96	0.178	0.973	0.71	
						60 Hz	0.306	43.33	3.12				
	40	1.362	7.447	5.446	0.20	50 Hz	0.667	94.46	6.80	0.735	4.019	2.94	
						60 Hz	0.513	72.65	5.23				
	60	1.862	10.180	7.447	0.39	50 Hz	1.031	146.00	10.51	0.875	4.784	3.50	
						60 Hz	0.767	108.62	7.82				
	90	2.286	12.499	9.143	0.39	50 Hz	1.429	202.36	14.57	1	5.468	4.0	
						60 Hz	1.065	150.82	10.86				

Outline of electromagnetic brake motor

(2) Stop time

The brake of the electromagnetic brake motor is activated when the power is turned off. However there exists some delay time between power-off and brake activation due to the mechanism of the brake. You can obtain the stop time of the electromagnetic brake motor from the following formula.

• SI units

$$T_b = T_a + T_{b1}$$

$$T_{b1} = \frac{J_M + J_L}{9.55 \times 10^4} \times \frac{n}{T_{bB}}$$

T_b : Stop time of electromagnetic brake motor (s)

T_a : Absorbing time of armature :

Separate switching About 0.02 sec

Simultaneous switching About 0.1 sec

T_{b1} : Braking time (s)

T_{bB} : Brake torque of electromagnetic brake motor (N·m)

• Gravitational system of units

$$T_b = T_a + T_{b1}$$

$$T_{b1} = \frac{GD^2_M + GD^2_L}{37500} \times \frac{n}{T_{bB}}$$

T_b : Stop time of electromagnetic brake motor (s)

T_a : Absorbing time of armature :

Separate switching About 0.02 sec

Simultaneous switching About 0.1 sec

T_{b1} : Braking time (s)

T_{bB} : Brake torque of electromagnetic brake motor (kgf·cm)

(3) Stop time and overrun

An overrun is defined as a revolution which the motor makes when the stop signal is inputted. You can obtain the overrun of the electromagnetic brake motor from the following formula, considering the absorbing time of the

$$nbB = a + \frac{n}{120} \times tb1 \dots\dots\dots(5)$$

where

nbB : Overrun of electromagnetic brake motor (revolution)

a : Constant due to delay

Separate switching: 0.43 (50 Hz), 0.53 (60 Hz)

Simultaneous switching: 2.15 (50 Hz), 2.65 (60 Hz)

(4) Overrun of gear head output shaft

The overrun of the gear head output shaft is obtained by dividing the overrun of the electromagnetic brake motor by the gear reduction ratio.

• Overrun in revolution $nGbB = nbB \times \frac{1}{i}$

• Overrun in angle $\thetaGbB = 360nGbB$

where

$nGbB$: Overrun of gear head output shaft (revolution)

θGbB : Overrun of gear head output shaft (degree)

nbB : Overrun of electromagnetic brake motor (revolution)

Separate switching and simultaneous switching <In the case of single-phase power supply>

In the case of the electromagnetic brake motor, the stop time varies depending on the position where the switch is connected.

In the case of a simultaneous switching circuit, because the motor coil and brake coil are in a closed loop, the release time of the armature is made longer due to the effect of the residual magnetic flux to the coil, resulting in a longer stop time.

When a shorter stop time is required, use a separate switching circuit.

• Separate switching circuit

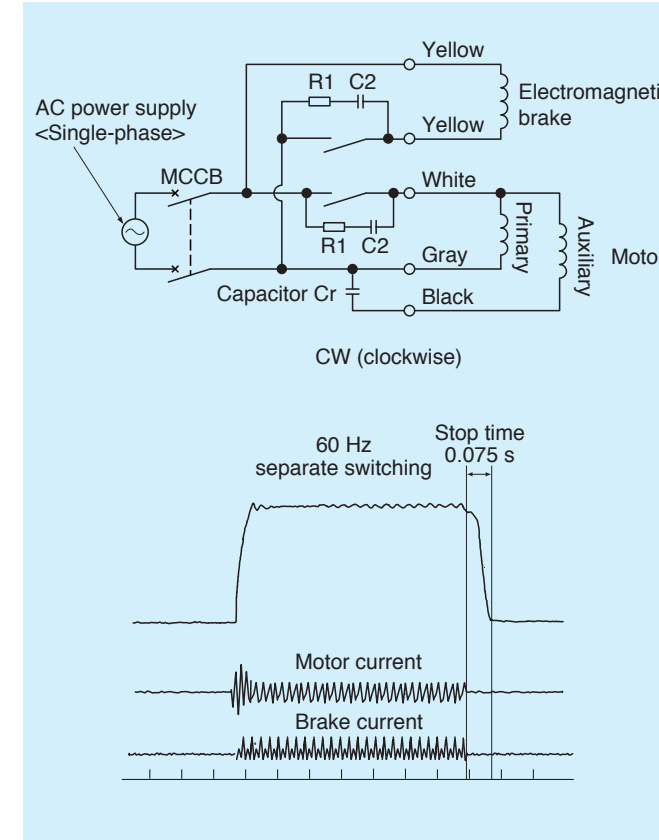

• Simultaneous switching circuit

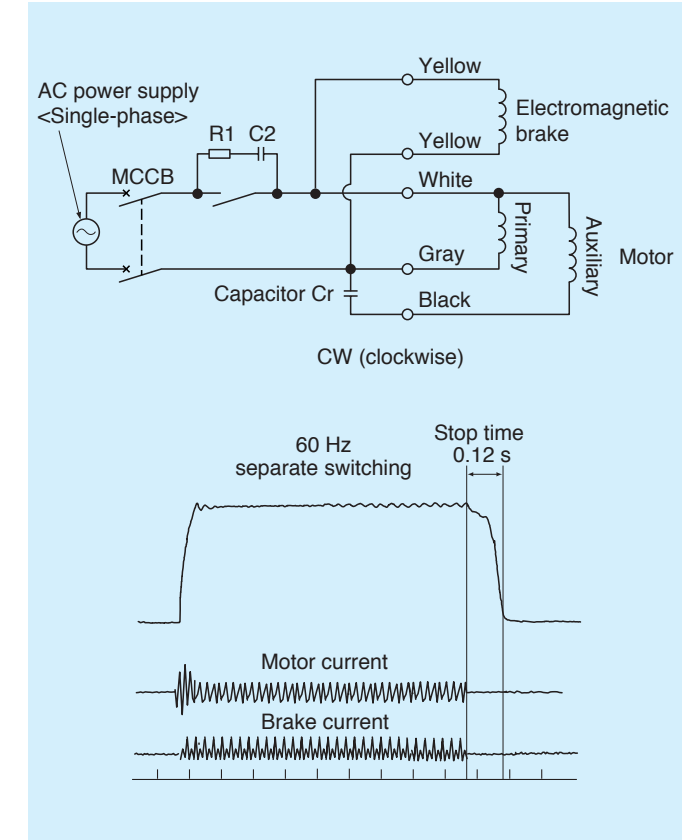

Life expectancy

The life expectancy of the brake of the electromagnetic brake motor is one million cycles at the permissible inertia load.

The permissible inertia load of the electromagnetic brake motor is shown on page A-51, which should not be exceeded.

Model list of electromagnetic brake motor

Pinion shaft motor

Applicable gear head

★ Motor compliant with overseas standards 

 Hinge attached

Size	Output (W)	single-phase motor, leadwire type			3-phase motor, leadwire type		
		Model number	Specifications	Page	Model number	Specifications	Page
60 mm sq. (2.36 inch sq.)	4						
	6	M6RX6GB4L	100 V	B-178			
		M6RX6GB4Y	200 V	B-178			
		M6RX6GB4LG(A)	100 V ★	B-180			
		M6RX6GB4DG(A)	110 V/115 V ★	B-180			
M6RX6GB4YG(A)	200 V ★	B-180					
M6RX6GB4GG(A)	220 V/230 V ★	B-180					
70 mm sq. (2.76 inch sq.)	10						
	15	M7RX15GB4L	100 V	B-182			
		M7RX15GB4Y	200 V	B-182			
		M7RX15GB4LG(A)	100 V ★	B-184			
		M7RX15GB4DG(A)	110 V/115 V ★	B-184			
M7RX15GB4YG(A)	200 V ★	B-184					
M7RX15GB4GG(A)	220 V/230 V ★	B-184					
80 mm sq. (3.15 inch sq.)	20						
	25	M8RX25GB4L	100 V	B-186			
		M8RX25GB4Y	200 V	B-186	M8MX25GB4Y	200 V	B-202
		M8RX25GB4LG(A)	100 V ★	B-188			
		M8RX25GB4DG(A)	110 V/115 V ★	B-188			
M8RX25GB4YG(A)	200 V ★	B-188	M8MX25GB4YG(A)	200 V/220 V/230 V ★	B-204		
M8RX25GB4GG(A)	220 V/230 V ★	B-188					
90 mm sq. (3.54 inch sq.)	40	M9RX40GB4L	100 V	B-190			
		M9RX40GB4Y	200 V	B-190	M9MX40GB4Y	200 V	B-206
		M9RX40GB4LG(A)	100 V ★	B-192			
		M9RX40GB4DG(A)	110 V/115 V ★	B-192			
		M9RX40GB4YG(A)	200 V ★	B-192	M9MX40GB4YG(A)	200 V/220 V/230 V ★	B-208
		M9RX40GB4GG(A)	220 V/230 V ★	B-192			
	60	M9RZ60GB4L	100 V	B-194			
		M9RZ60GB4Y	200 V	B-194	M9MZ60GB4Y	200 V	B-210
		M9RZ60GB4LG(A)	100 V ★	B-196			
		M9RZ60GB4DG(A)	110 V/115 V ★	B-196			
		M9RZ60GB4YG(A)	200 V ★	B-196	M9MZ60GB4YG(A)	200 V/220 V/230 V ★	B-212
		M9RZ60GB4GG(A)	220 V/230 V ★	B-196			
90	M9RZ90GB4L	100 V	B-198				
	M9RZ90GB4Y	200 V	B-198	M9MZ90GB4Y	200 V	B-214	
	M9RZ90GB4LG(A)	100 V ★	B-200				
	M9RZ90GB4DG(A)	110 V/115 V ★	B-200				
	M9RZ90GB4YG(A)	200 V ★	B-200	M9MZ90GB4YG(A)	200 V/220 V/230 V ★	B-216	
	M9RZ90GB4GG(A)	220 V/230 V ★	B-200				



Standard gear head		High torque gear head	Right-angle gear head	Gear head -Inch (U.S.A.)	Decimal gear head
Ball bearing	metal bearing				
MX6G□BA MX6G□B	MX6G□MA MX6G□M	—	—	MX6G□BU	MX6G10XB
MX7G□BA MX7G□B	MX7G□MA MX7G□M	—	—	MX7G□BU	MX7G10XB
MX8G□B	MX8G□M	—	—	MX8G□BU	MX8G10XB
MX9G□B	MX9G□M	—	MX9G□R	MX9G□BU	MX9G10XB
MZ9G□B	—	MR9G□B	MZ9G□R	MZ9G□BU	MZ9G10XB
MY9G□B	—	MP9G□B			

* The models with a motor model number to which "A" is suffixed are not equipped with a capacitor cap.
The models with a motor model number to which "A" is suffixed are not sold or available in Japan.

* Refer to page B-444 for dimensions and permissible torque of high torque gear head.
Refer to page B-446 for dimensions and permissible torque of right-angle gear head.
Refer to page B-451 for dimensions and permissible torque of gear head -Inch (U.S.A.).
Refer to page B-448 for dimensions of decimal gear head.

Model list of electromagnetic brake motor

Round shaft motor

★ Motor compliant with overseas standards   
 ㊦ Electrical Appliance and Material Safety Law

Size	Output (W)	single-phase motor, leadwire type		3-phase motor, leadwire type	
		Model number	Specifications	Model number	Specifications
60 mm sq. (2.36 inch sq.)	4				
	6	M6RX6SB4LS	100 V		
		M6RX6SB4YS	200 V		
		M6RX6SB4LG(A)	100 V	★	
		M6RX6SB4DG(A)	110 V/115 V	★	
		M6RX6SB4YG(A)	200 V	★	
M6RX6SB4GG(A)	220 V/230 V	★			
70 mm sq. (2.76 inch sq.)	10				
	15	M7RX15SB4LS	100 V		
		M7RX15SB4YS	200 V		
		M7RX15SB4LG(A)	100 V	★	
		M7RX15SB4DG(A)	110 V/115 V	★	
		M7RX15SB4YG(A)	200 V	★	
M7RX15SB4GG(A)	220 V/230 V	★			
80 mm sq. (3.15 inch sq.)	20				
	25	M8RX25SB4LS	100 V		
		M8RX25SB4YS	200 V		M8MX25SB4YS 200 V
		M8RX25SB4LG(A)	100 V	★	
		M8RX25SB4DG(A)	110 V/115 V	★	
		M8RX25SB4YG(A)	200 V	★	M8MX25SB4YG(A) 200 V/220 V/230 V ★
M8RX25SB4GG(A)	220 V/230 V	★			
90 mm sq. (3.54 inch sq.)	40	M9RX40SB4LS	100 V		
		M9RX40SB4YS	200 V		M9MX40SB4YS 200 V
		M9RX40SB4LG(A)	100 V	★	
		M9RX40SB4DG(A)	110 V/115 V	★	
		M9RX40SB4YG(A)	200 V	★	M9MX40SB4YG(A) 200 V/220 V/230 V ★
		M9RX40SB4GG(A)	220 V/230 V	★	
	60	M9RZ60SB4LS	100 V		
		M9RZ60SB4YS	200 V		M9MZ60SB4YS 200 V
		M9RZ60SB4LG(A)	100 V	★	
		M9RZ60SB4DG(A)	110 V/115 V	★	
		M9RZ60SB4YG(A)	200 V	★	M9MZ60SB4YG(A) 200 V/220 V/230 V ★
		M9RZ60SB4GG(A)	220 V/230 V	★	
	90	M9RZ90SB4LS	100 V		
		M9RZ90SB4YS	200 V		M9MZ90SB4YS 200 V
		M9RZ90SB4LG(A)	100 V	★	
		M9RZ90SB4DG(A)	110 V/115 V	★	
		M9RZ90SB4YG(A)	200 V	★	M9MZ90SB4YG(A) 200 V/220 V/230 V ★
		M9RZ90SB4GG(A)	220 V/230 V	★	

* The specifications and wire connections of the round shaft motor are the same as those of the pinion shaft motor.
 Dimensional outline drawing → Page B-220.

* The models with a motor model number to which "A" is suffixed are not equipped with a capacitor cap.
 The models with a motor model number to which "A" is suffixed are not sold or available in Japan.

Electromagnetic brake single-phase motor (leadwire)

60 mm (2.36 inch) sq. 6 W

Specifications

Size	Motor model No.	Number of pole (P)	Output (W)	Voltage (V)	Frequency (Hz)	Rating (min)	Rating				Starting current (A)	Starting torque N·m (oz-in)	Brake Input (W)	Brake Current (A)	Brake Friction Torque N·m (oz-in)	Capacitor (μF) (rated voltage)
							Input (W)	Current (A)	Speed (r/min)	Torque N·m (oz-in)						
60 mm sq.	M6RX6GB4L	4	6	100	50	30	22	0.22	1300	0.044 (6.23)	0.32	0.056 (7.93)	4	0.04	0.049 (6.94)	3.5 (200 V)
							22	0.22	1600	0.035 (4.96)	0.32	0.056 (7.93)	4	0.04	0.049 (6.94)	
	M6RX6GB4Y	4	6	200	50	30	25	0.13	1300	0.044 (6.23)	0.17	0.056 (7.93)	4	0.02	0.049 (6.94)	0.9 (400 V)
							25	0.13	1600	0.035 (4.96)	0.18	0.056 (7.93)	4	0.02	0.049 (6.94)	

* The specifications and wire connections of the round shaft motor are the same as those of the pinion shaft type. For the dimensional outline drawing, refer to page B-220.

Permissible torque at output shaft of gear head

* The speed shown below is a calculated value based on the synchronous rotational speed. Depending on the load, the speed is less than the indicated value by 2% to 20%.

Unit of permissible torque: upper (N·m) / lower (lb-in)

Reduction ratio	Unit of permissible torque: upper (N·m) / lower (lb-in)																							
	3	3.6	5	6	7.5	9	10	12.5	15	18	20	25	30	36	50	60	75	90	100	120	150	180		
Speed (r/min)	50 Hz	500	416.7	300	250	200	166.7	150	120	100	83.3	75	60	50	41.7	30	25	20	16.7	15	12.5	10	8.3	
	60 Hz	600	500	360	300	240	200	180	144	120	100	90	72	60	50	36	30	24	20	18	15	12	10	
Applicable gear head	MX6G3BA to MX6G180B (ball bearing)	50 Hz	0.098 (0.87)	0.12 (1.06)	0.16 (1.42)	0.19 (1.68)	0.25 (2.21)	0.29 (2.57)	0.33 (2.92)	0.40 (3.54)	0.49 (4.34)	0.59 (5.22)	0.66 (5.84)	0.79 (6.99)	0.95 (8.41)	1.18 (10.4)	1.57 (13.9)	1.86 (16.5)	2.25 (19.9)	2.45 (21.7)				
		60 Hz	0.081 (0.72)	0.098 (0.87)	0.13 (1.15)	0.16 (1.42)	0.21 (1.86)	0.25 (2.21)	0.26 (2.30)	0.33 (2.92)	0.40 (3.54)	0.49 (4.34)	0.53 (4.69)	0.66 (5.84)	0.79 (6.99)	0.95 (8.41)	1.27 (11.2)	1.57 (13.9)	1.86 (16.5)	2.25 (19.9)	2.45 (21.7)			
	MX6G3MA to MX6G180M (metal bearing)	50 Hz	0.098 (0.87)	0.12 (1.06)	0.16 (1.42)	0.19 (1.68)	0.25 (2.21)	0.29 (2.57)	0.33 (2.92)	0.40 (3.54)	0.49 (4.34)	0.59 (5.22)	0.66 (5.84)	0.79 (6.99)	0.95 (8.41)	1.18 (10.4)	1.57 (13.9)	1.86 (16.5)	2.25 (19.9)	2.45 (21.7)				
	MX6G3MA to MX6G180M (metal bearing)	60 Hz	0.081 (0.72)	0.098 (0.87)	0.13 (1.15)	0.16 (1.42)	0.21 (1.86)	0.25 (2.21)	0.26 (2.30)	0.33 (2.92)	0.40 (3.54)	0.49 (4.34)	0.53 (4.69)	0.66 (5.84)	0.79 (6.99)	0.95 (8.41)	1.27 (11.2)	1.57 (13.9)	1.86 (16.5)	2.25 (19.9)	2.45 (21.7)			
Rotational direction	Same as motor rotational direction											Reverse to motor rotational direction												

Permissible torque at output shaft of gear head using decimal gear head

Applicable gear head		Reduction ratio	Reduction ratio													
Bearing	Decimal gear head		Speed (r/min)	200	250	300	360	500	600	750	900	1000	1200	1500	1800	
MX6G□BA (ball bearing)	MX6G□B (ball bearing)	MX6G10XB	50 Hz	7.5	6	5	4.2	3	2.5	2	1.7	1.5	1.3	1	0.8	
			60 Hz	9	7.2	6	5	3.6	3	2.4	2	1.8	1.5	1.2	1	
MX6G□MA (metal bearing)	MX6G□M (metal bearing)		Permissible torque (N·m / lb-in)	2.45 (21.7)	2.45 (21.7)	2.45 (21.7)	2.45 (21.7)	2.45 (21.7)	2.45 (21.7)	2.45 (21.7)	2.45 (21.7)	2.45 (21.7)	2.45 (21.7)	2.45 (21.7)	2.45 (21.7)	
Rotational direction			Same as motor rotational direction / Reverse to motor rotational direction													

Connection diagram

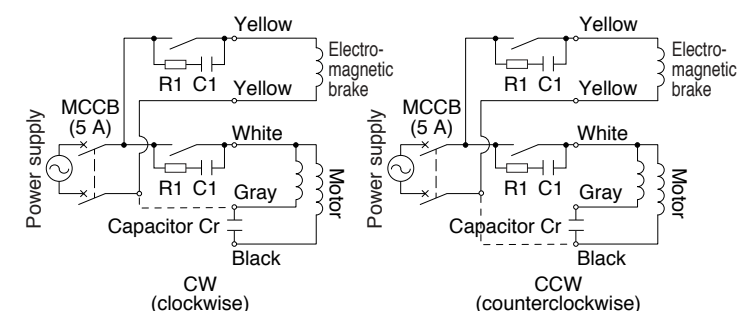

<Note>
 1. Brake will be activated and held when electromagnetic brake power is turned OFF.
 2. Protect the contacts by inserting the spark-killer circuit (R1+C1) between the contacts. R1+C1 is provided as an option (DV0P008A, refer to page D-3).
 3. Use a circuit breaker for the power supply.

Speed-torque characteristics

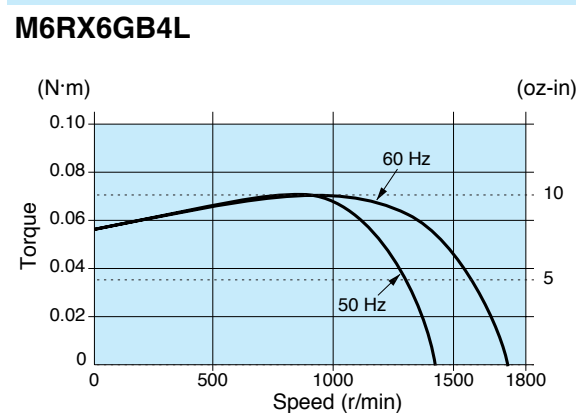

Motor (dimensions)

Scale: 1/3, Unit: mm (inch)

M6RX6GB4L 4P 6 W 100 V
 M6RX6GB4Y 4P 6 W 200 V

Mass 1.0 kg 2.20 lb
 Helical gear
 Module 0.5
 Number of teeth 6

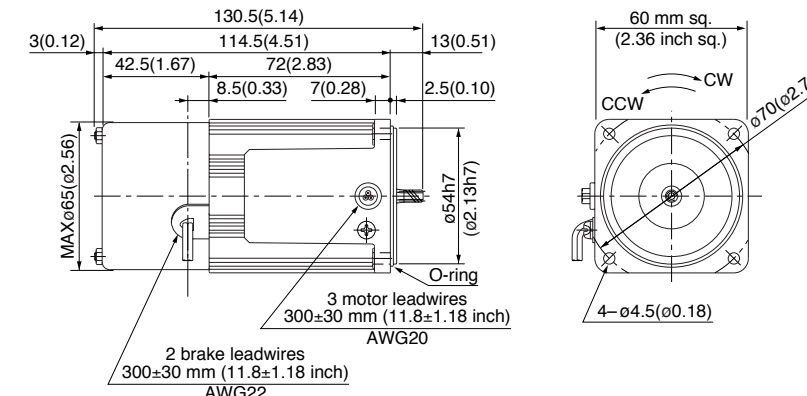

Capacitor (dimensions) [attachment]

Unit: mm (inch)

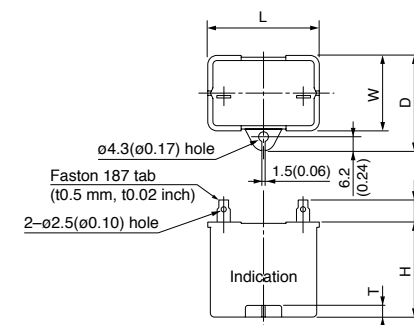

Capacitor cap (dimensions) [option]

Unit: mm (inch)

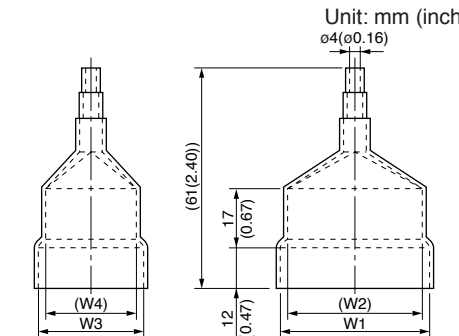

Capacitor dimension list Unit: upper (mm) / lower (inch)

Model number of motor	Model number of capacitor (attachment)	L	W	D	H	T	Capacitor cap (option)	W1	W2	W3	W4
M6RX6GB4L	M0PC3.5M20	39.5 (1.56)	16 (0.63)	26.5 (1.04)	30.5 (1.20)	4 (0.16)	M0PC3917	39.5 (1.56)	37.5 (1.48)	17 (0.67)	15 (0.59)
M6RX6GB4Y	M0PC0.9M40	39.5 (1.56)	16.2 (0.64)	27 (1.06)	27 (1.06)	4 (0.16)	M0PC3917	39.5 (1.56)	37.5 (1.48)	17 (0.67)	15 (0.59)

Gear head (dimensions)

Scale: 1/3, Unit: mm (inch)

MX6G□BA (ball bearing) Mass 0.24 kg (0.53 lb): Output shaft D cut
 MX6G□B (ball bearing) Mass 0.3 kg (0.66 lb): Output shaft D cut
 MX6G□MA (metal bearing) Mass 0.24 kg (0.53 lb): Output shaft D cut
 MX6G□M (metal bearing) Mass 0.3 kg (0.66 lb): Output shaft D cut

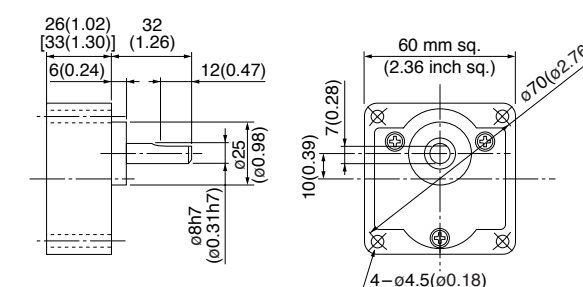

* Figures in [] represent the dimensions of MX6G□B (M) (1/30 or larger reduction ratio).

(The model number of the gear head with a reduction ratio of 1/25 or smaller is MX6G□BA (MA).)

(Note) Because the dimensions may be subject to change, also check the determinate dimensions if the gear head is to be used for design.

Electromagnetic brake single-phase motor (leadwire)

60 mm (2.36 inch) sq. **6 W**

Specifications

Size	Motor model No.	Number of pole (P)	Output (W)	Voltage (V)	Frequency (Hz)	Rating (min)	Rating				Starting current (A)	Starting torque N·m (oz-in)	Brake Input (W)	Brake Current (A)	Brake Friction Torque N·m (oz-in)	Capacitor (μF) (rated voltage)
							Input (W)	Current (A)	Speed (r/min)	Torque N·m (oz-in)						
60 mm sq.	M6RX6GB4LG M6RX6GB4LGA	4	6	100	50	30	24	0.24	1300	0.044 (6.23)	0.34	0.063 (8.92)	4	0.04	0.049 (6.94)	4
							26	0.26	1625	0.035 (4.96)	0.35	0.063 (8.92)	4	0.04	0.049 (6.94)	(250 V)
	M6RX6GB4DG M6RX6GB4DGA	4	6	110	60	30	24	0.22	1625	0.035 (4.96)	0.34	0.057 (8.07)	4	0.05	0.049 (6.94)	3
							26	0.23	1625	0.035 (4.96)	0.36	0.063 (8.92)	5	0.05	0.049 (6.94)	(250 V)
	M6RX6GB4YG M6RX6GB4YGA	4	6	200	50	30	24	0.12	1275	0.045 (6.37)	0.15	0.063 (8.92)	4	0.02	0.049 (6.94)	1
							28	0.14	1550	0.037 (5.24)	0.16	0.063 (8.92)	4	0.02	0.049 (6.94)	(450 V)
	M6RX6GB4GG M6RX6GB4GGA	4	6	220	50	30	24	0.11	1275	0.045 (6.37)	0.15	0.063 (8.92)	4	0.02	0.049 (6.94)	0.8
							26	0.12	1600	0.036 (5.10)	0.16	0.063 (8.92)	4	0.02	0.049 (6.94)	
					60	30	26	0.12	1300	0.044 (6.23)	0.16	0.069 (9.77)	5	0.02	0.049 (6.94)	0.8
							28	0.12	1625	0.035 (4.96)	0.16	0.069 (9.77)	5	0.02	0.049 (6.94)	

• The specifications and wire connections of the round shaft motor are the same as those of the pinion shaft type. For the dimensional outline drawing, refer to page B-220.
 • The models with a motor model number to which "A" is suffixed are not equipped with a capacitor cap.
 • The models with a motor model number to which "A" is suffixed are not sold or available in Japan.

Permissible torque at output shaft of gear head

* The speed shown below is a calculated value based on the synchronous rotational speed. Depending on the load, the speed is less than the indicated value by 2 % to 20 %.

Unit of permissible torque: upper (N·m) / lower (lb-in)

Reduction ratio	Unit of permissible torque: upper (N·m) / lower (lb-in)																							
	3	3.6	5	6	7.5	9	10	12.5	15	18	20	25	30	36	50	60	75	90	100	120	150	180		
Speed (r/min)	50 Hz	500	416.7	300	250	200	166.7	150	120	100	83.3	75	60	50	41.7	30	25	20	16.7	15	12.5	10	8.3	
	60 Hz	600	500	360	300	240	200	180	144	120	100	90	72	60	50	36	30	24	20	18	15	12	10	
Applicable gear head	50 Hz	0.098 (0.87)	0.12 (1.06)	0.16 (1.42)	0.19 (1.68)	0.25 (2.21)	0.29 (2.57)	0.33 (2.92)	0.40 (3.54)	0.49 (4.34)	0.59 (5.22)	0.66 (5.84)	0.79 (6.99)	0.95 (8.41)	1.18 (10.4)	1.57 (13.9)	1.86 (16.5)	2.25 (19.9)	2.45 (21.7)					2.45 (21.7)
	60 Hz	0.081 (0.72)	0.098 (0.87)	0.13 (1.15)	0.16 (1.42)	0.21 (1.86)	0.25 (2.21)	0.26 (2.30)	0.33 (2.92)	0.40 (3.54)	0.49 (4.34)	0.53 (4.69)	0.66 (5.84)	0.79 (6.99)	0.95 (8.41)	1.27 (11.2)	1.57 (13.9)	1.86 (16.5)	2.25 (19.9)					2.45 (21.7)
Rotational direction	Same as motor rotational direction											Reverse to motor rotational direction												

Permissible torque at output shaft of gear head using decimal gear head

Applicable gear head	Reduction ratio	Permissible torque												
		200	250	300	360	500	600	750	900	1000	1200	1500	1800	
Bearing	Speed (r/min)	50 Hz	7.5	6	5	4.2	3	2.5	2	1.7	1.5	1.3	1	0.8
		60 Hz	9	7.2	6	5	3.6	3	2.4	2	1.8	1.5	1.2	1
MX6G□BA (ball bearing)	MX6G10XB	Permissible torque (N·m) (lb-in)	2.45 (21.7)	2.45 (21.7)	2.45 (21.7)	2.45 (21.7)	2.45 (21.7)	2.45 (21.7)	2.45 (21.7)	2.45 (21.7)	2.45 (21.7)	2.45 (21.7)	2.45 (21.7)	2.45 (21.7)
MX6G□B (bearing)			2.45 (21.7)	2.45 (21.7)	2.45 (21.7)	2.45 (21.7)	2.45 (21.7)	2.45 (21.7)	2.45 (21.7)	2.45 (21.7)	2.45 (21.7)	2.45 (21.7)	2.45 (21.7)	2.45 (21.7)
MX6G□MA (metal bearing)	MX6G10XB	Rotational direction	Same as motor rotational direction						Reverse to motor rotational direction					
MX6G□M (bearing)														

Connection diagram

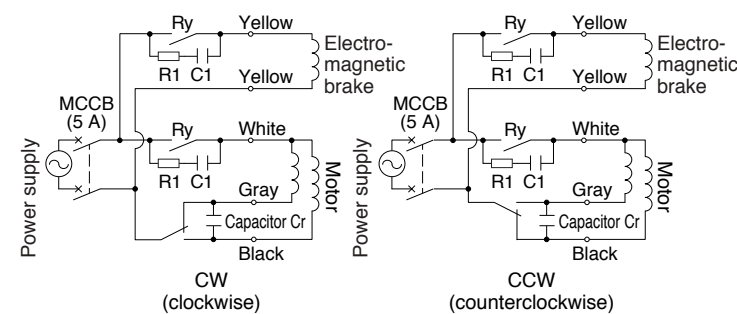

<Note>
 1. Brake will be activated and held when electromagnetic brake power is turned OFF.
 2. Protect the contacts by inserting the spark-killer circuit (R1+C1) between the contacts. R1+C1 is provided as an option (DV0P008A, refer to page D-3).
 3. Use a circuit breaker for the power supply.

Speed-torque characteristics

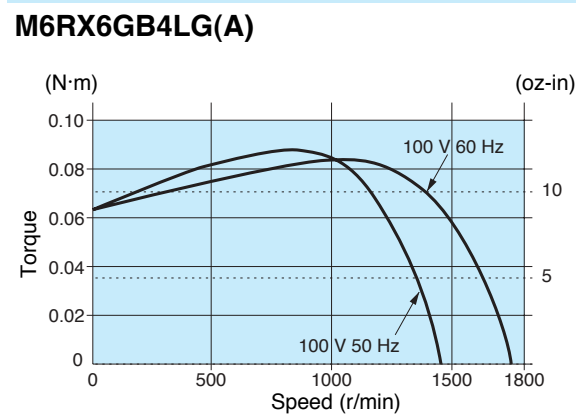

Motor (dimensions)

Scale: 1/3, Unit: mm (inch)

M6RX6GB4LG(A)	4P 6 W 100 V
M6RX6GB4DG(A)	4P 6 W 110 V / 115 V
M6RX6GB4YG(A)	4P 6 W 200 V
M6RX6GB4GG(A)	4P 6 W 220 V / 230 V

Mass **1.0 kg** (2.20 lb)
 Helical gear
 Module **0.5**
 Number of teeth **6**

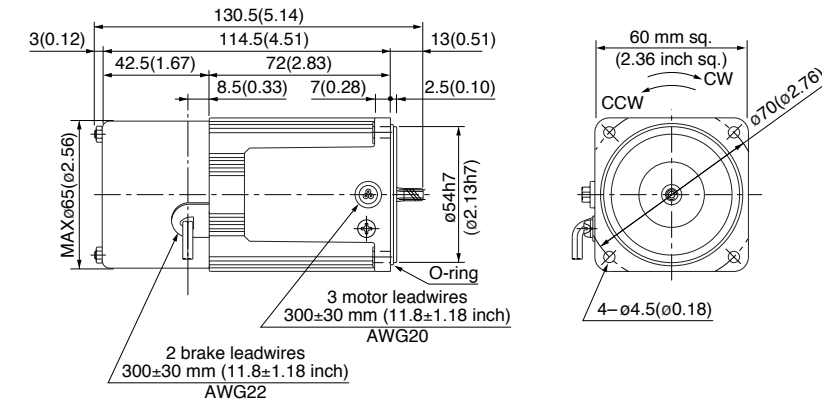

Capacitor (dimensions) [attachment]

Unit: mm (inch)

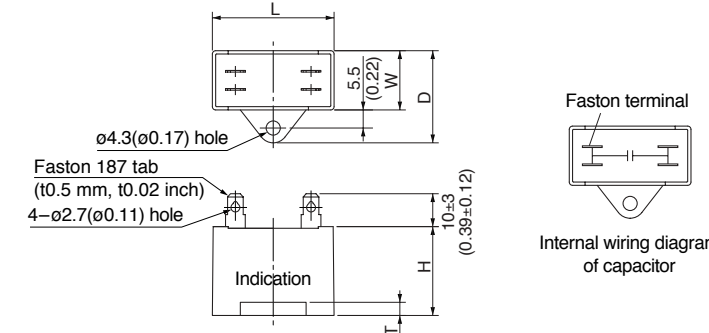

Capacitor cap (dimensions) [attachment]

Unit: mm (inch)

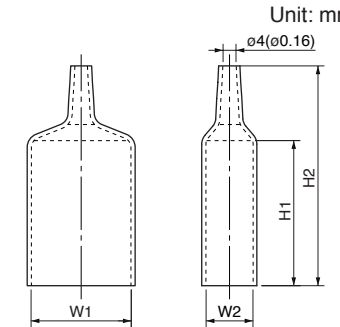

Capacitor dimension list

Unit: upper (mm) / lower (inch)

Model number of motor	Model number of capacitor (attachment)	L	W	D	H	T	Capacitor cap (attachment)	W1	W2	H1	H2
M6RX6GB4LG(A)	M0PC4M25G	37 (1.46)	18 (0.71)	28 (1.10)	27 (1.06)	4 (0.16)	M0PC3718G	37 (1.46)	18 (0.71)	50 (1.97)	73 (2.87)
M6RX6GB4DG(A)	M0PC3M25G	31 (1.22)	17 (0.67)	27 (1.06)	27 (1.06)	4 (0.16)	M0PC3117G	31 (1.22)	17 (0.67)	50 (1.97)	73 (2.87)
M6RX6GB4YG(A)	M0PC1M45G	37 (1.46)	18 (0.71)	28 (1.10)	27 (1.06)	4 (0.16)	M0PC3718G	37 (1.46)	18 (0.71)	50 (1.97)	73 (2.87)
M6RX6GB4GG(A)	M0PC0.8M45G	31 (1.22)	17 (0.67)	27 (1.06)	27 (1.06)	4 (0.16)	M0PC3117G	31 (1.22)	17 (0.67)	50 (1.97)	73 (2.87)

* The models with a motor model number to which "A" is suffixed are not equipped with a capacitor cap.

Gear head (dimensions)

Scale: 1/3, Unit: mm (inch)

MX6G□BA (ball bearing)	Mass 0.24 kg (0.53 lb): Output shaft D cut	MX6G□B (ball bearing)	Mass 0.3 kg (0.66 lb): Output shaft D cut
MX6G□MA (metal bearing)	Mass 0.24 kg (0.53 lb): Output shaft D cut	MX6G□M (metal bearing)	Mass 0.3 kg (0.66 lb): Output shaft D cut

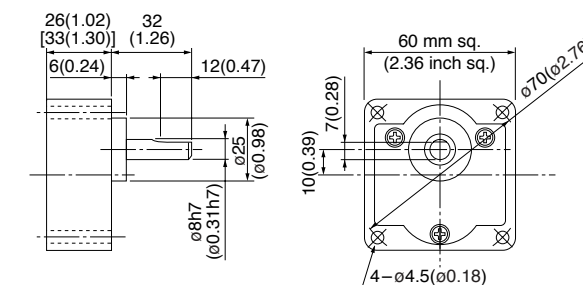

* Figures in [] represent the dimensions of MX6G□B (M) (1/30 or larger reduction ratio).

(The model number of the gear head with a reduction ratio of 1/25 or smaller is MX6G□BA (MA).)

(Note) Because the dimensions may be subject to change, also check the determinate dimensions if the gear head is to be used for design.

Electromagnetic brake single-phase motor (leadwire)

70 mm (2.76 inch) sq. 15 W

Specifications

Size	Motor model No.	Number of pole (P)	Output (W)	Voltage (V)	Frequency (Hz)	Rating (min)	Rating				Starting current (A)	Starting torque N·m (oz-in)	Brake Input (W)	Brake Current (A)	Brake Friction Torque N·m (oz-in)	Capacitor (μF) (rated voltage)
							Input (W)	Current (A)	Speed (r/min)	Torque N·m (oz-in)						
70 mm sq.	M7RX15GB4L	4	15	100	50	30	36	0.36	1300	0.110 (15.6)	0.59	0.10 (14.2)	4	0.05	0.078 (11.0)	6 (200 V)
							38	0.38	1600	0.088 (12.5)	0.57	0.10 (14.2)	4	0.05	0.078 (11.0)	
	M7RX15GB4Y	4	15	200	50	30	38	0.18	1300	0.110 (15.6)	0.28	0.10 (14.2)	4	0.02	0.078 (11.0)	1.5 (400 V)
							39	0.19	1600	0.088 (12.5)	0.28	0.10 (14.2)	4	0.02	0.078 (11.0)	

* The specifications and wire connections of the round shaft motor are the same as those of the pinion shaft type. For the dimensional outline drawing, refer to page B-220.

Permissible torque at output shaft of gear head

* The speed shown below is a calculated value based on the synchronous rotational speed. Depending on the load, the speed is less than the indicated value by 2% to 20%.

Unit of permissible torque: upper (N·m) / lower (lb-in)

Reduction ratio	Unit of permissible torque: upper (N·m) / lower (lb-in)																						
	3	3.6	5	6	7.5	9	10	12.5	15	18	20	25	30	36	50	60	75	90	100	120	150	180	
Speed (r/min)	50 Hz 60 Hz	500 600	416.7 500	300 360	250 300	200 240	166.7 200	150 180	120 144	100 120	83.3 90	75 90	60 72	50 60	41.7 50	30 36	25 30	20 24	16.7 20	15 18	12.5 15	10 12	8.3 10
Applicable gear head	50 Hz	MX7G3BA to MX7G180B (ball bearing)	0.24 (2.12)	0.28 (2.48)	0.39 (3.45)	0.47 (4.16)	0.59 (5.22)	0.71 (6.28)	0.80 (7.08)	0.98 (8.67)	1.18 (10.4)	1.37 (12.1)	1.57 (13.9)	1.86 (16.5)	2.25 (19.9)	2.74 (24.3)	3.82 (33.8)	4.61 (40.8)	4.90 (43.4)				
		MX7G3MA to MX7G180M (metal bearing)	0.20 (1.77)	0.24 (2.12)	0.32 (2.83)	0.39 (3.45)	0.49 (4.34)	0.59 (5.22)	0.66 (5.84)	0.81 (7.17)	0.98 (8.67)	1.18 (10.4)	1.27 (11.2)	1.57 (13.9)	1.86 (16.5)	2.25 (19.9)	3.23 (28.6)	3.82 (33.8)	4.80 (42.5)				
Rotational direction	Same as motor rotational direction											Reverse to motor rotational direction											

Permissible torque at output shaft of gear head using decimal gear head

Applicable gear head		Reduction ratio	Unit of permissible torque: upper (N·m) / lower (lb-in)													
Bearing	Decimal gear head		Speed (r/min)	50 Hz	7.5	6	5	4.2	3	2.5	2	1.7	1.5	1.3	1	0.8
MX7G□BA (ball bearing)	MX7G10XB	Permissible torque	N·m (lb-in)	4.90 (43.4)	4.90 (43.4)	4.90 (43.4)	4.90 (43.4)	4.90 (43.4)	4.90 (43.4)	4.90 (43.4)	4.90 (43.4)	4.90 (43.4)	4.90 (43.4)	4.90 (43.4)	4.90 (43.4)	4.90 (43.4)
MX7G□B (ball bearing)				4.90 (43.4)	4.90 (43.4)	4.90 (43.4)	4.90 (43.4)	4.90 (43.4)	4.90 (43.4)	4.90 (43.4)	4.90 (43.4)	4.90 (43.4)	4.90 (43.4)	4.90 (43.4)	4.90 (43.4)	4.90 (43.4)
MX7G□MA (metal bearing)		Rotational direction	Same as motor rotational direction													
MX7G□M (metal bearing)			Reverse to motor rotational direction													

Connection diagram

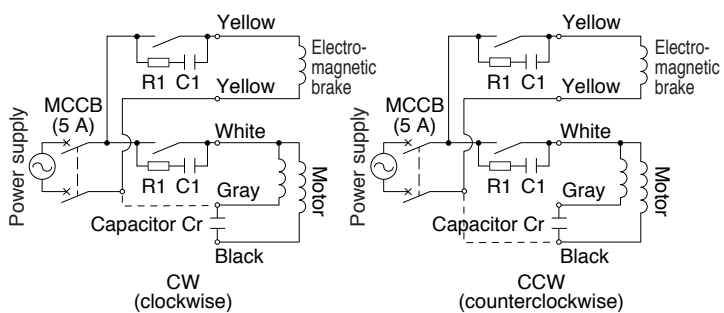

- <Note>**
- Brake will be activated and held when electromagnetic brake power is turned OFF.
 - Protect the contacts by inserting the spark-killer circuit (R1+C1) between the contacts. R1+C1 is provided as an option (DV0P008A, refer to page D-3).
 - Use a circuit breaker for the power supply.

Speed-torque characteristics

M7RX15GB4L

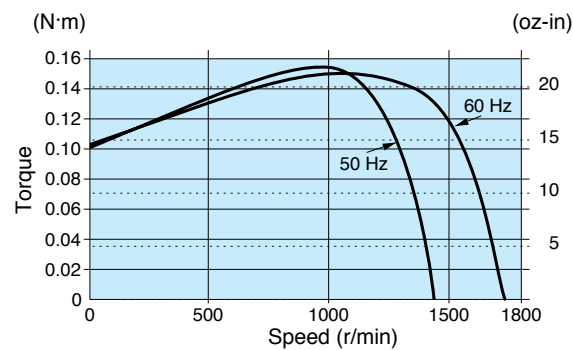

Motor (dimensions)

Scale: 1/3, Unit: mm (inch)

M7RX15GB4L	4P 15 W 100 V
M7RX15GB4Y	4P 15 W 200 V

Mass	Helical gear	Module	Number of teeth
1.5 kg 3.31 lb		0.5	7

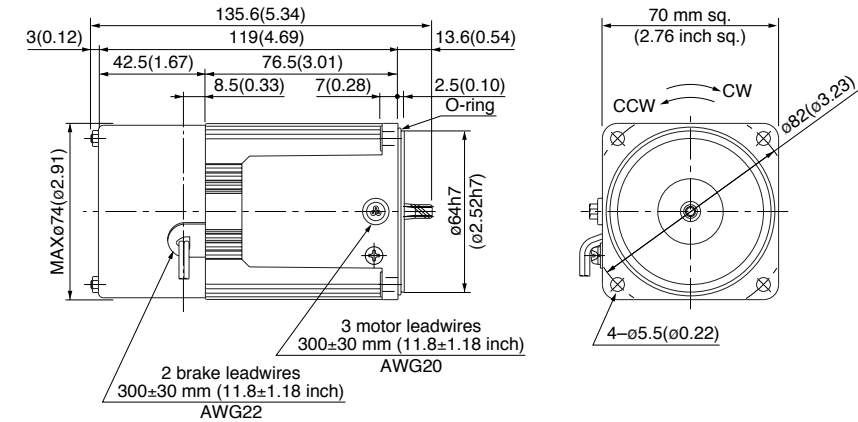

Capacitor (dimensions) [attachment]

Unit: mm (inch)

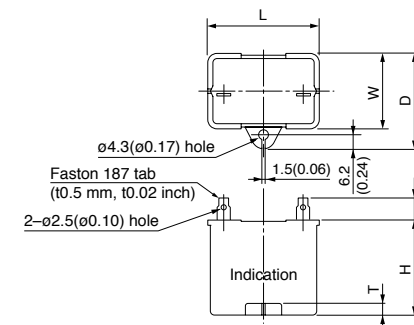

Capacitor cap (dimensions) [option]

Unit: mm (inch)

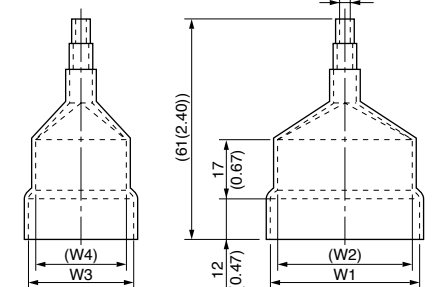

Capacitor dimension list Unit: upper (mm) / lower (inch)

Model number of motor	Model number of capacitor (attachment)	L	W	D	H	T	Capacitor cap (option)	W1	W2	W3	W4
M7RX15GB4L	M0PC6M20	39.5 (1.56)	17.5 (0.69)	28 (1.10)	30.5 (1.20)	4 (0.16)	M0PC3917	39.5 (1.56)	37.5 (1.48)	17 (0.67)	15 (0.59)
M7RX15GB4Y	M0PC1.5M40	39.5 (1.56)	22 (0.87)	32.5 (1.28)	32.5 (1.28)	4 (0.16)	M0PC3922	39.5 (1.56)	37.5 (1.48)	22 (0.87)	20 (0.79)

Gear head (dimensions)

Scale: 1/3, Unit: mm (inch)

MX7G□BA (ball bearing)	Mass 0.38 kg (0.84 lb)
MX7G□MA (metal bearing)	Mass 0.38 kg (0.84 lb)

MX7G□B (ball bearing)	Mass 0.45 kg (0.99 lb)
MX7G□M (metal bearing)	Mass 0.45 kg (0.99 lb)

Key and keyway (dimensions) [attachment]

MX7G□BA(B)	Key width: 25(0.98)
MX7G□MA(M)	Key width: 25(0.98)

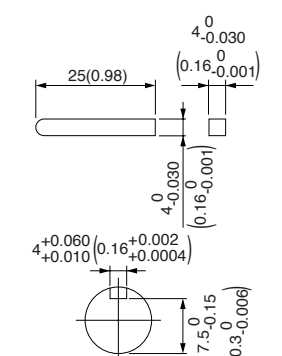
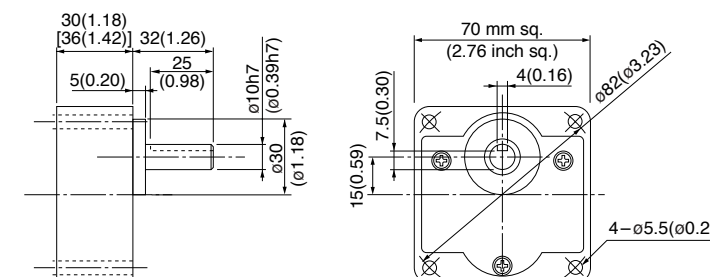

* Figures in [] represent the dimensions of MX7G□B (M) (1/30 or larger reduction ratio).

(The model number of the gear head with a reduction ratio of 1/25 or smaller is MX7G□BA (MA).)

(Note) Because the dimensions may be subject to change, also check the determinate dimensions if the gear head is to be used for design.

Electromagnetic brake single-phase motor (leadwire)

US CE 70 mm (2.76 inch) sq. 15 W

Specifications

Size	Motor model No.	Number of pole (P)	Output (W)	Voltage (V)	Frequency (Hz)	Rating (min)	Rating				Starting current (A)	Starting torque N·m (oz-in)	Brake Input (W)	Brake Current (A)	Brake Friction Torque N·m (oz-in)	Capacitor (μF) (rated voltage)
							Input (W)	Current (A)	Speed (r/min)	Torque N·m (oz-in)						
70 mm sq.	M7RX15GB4LG M7RX15GB4LGA	4	15	100	50	30	36	0.36	1300	0.11 (15.6)	0.60	0.11 (15.6)	4	0.05	0.078 (11.0)	6.5 (250 V)
							41	0.42	1600	0.090 (12.7)	0.59	0.11 (15.6)	4	0.05	0.078 (11.0)	
	M7RX15GB4DG M7RX15GB4DGA	4	15	110	60	30	39	0.36	1625	0.088 (12.5)	0.61	0.11 (15.6)	5	0.05	0.078 (11.0)	5.5 (250 V)
							42	0.36	1650	0.087 (12.3)	0.64	0.12 (17.0)	5	0.05	0.078 (11.0)	
	M7RX15GB4YG M7RX15GB4YGA	4	15	200	50	30	38	0.19	1275	0.11 (15.6)	0.27	0.11 (15.6)	4	0.02	0.078 (11.0)	1.7 (450 V)
							48	0.25	1550	0.092 (13.0)	0.29	0.11 (15.6)	4	0.02	0.078 (11.0)	
	M7RX15GB4GG M7RX15GB4GGA	4	15	220	60	30	36	0.17	1275	0.11 (15.6)	0.27	0.10 (14.2)	5	0.03	0.078 (11.0)	1.3 (450 V)
							39	0.18	1600	0.090 (12.7)	0.27	0.10 (14.2)	5	0.03	0.078 (11.0)	
							38	0.17	1300	0.11 (15.6)	0.28	0.11 (15.6)	5	0.03	0.078 (11.0)	
							41	0.18	1625	0.088 (12.5)	0.28	0.11 (15.6)	5	0.03	0.078 (11.0)	

The specifications and wire connections of the round shaft motor are the same as those of the pinion shaft type. For the dimensional outline drawing, refer to page B-220.
The models with a motor model number to which "A" is suffixed are not equipped with a capacitor cap.
The models with a motor model number to which "A" is suffixed are not sold or available in Japan.

Permissible torque at output shaft of gear head

The speed shown below is a calculated value based on the synchronous rotational speed. Depending on the load, the speed is less than the indicated value by 2% to 20%.

Unit of permissible torque: upper (N·m) / lower (lb-in)

Reduction ratio	Unit of permissible torque: upper (N·m) / lower (lb-in)																									
	3	3.6	5	6	7.5	9	10	12.5	15	18	20	25	30	36	50	60	75	90	100	120	150	180				
Speed (r/min)	50 Hz		60 Hz																							
Applicable gear head	Same as motor rotational direction																									
MX7G3BA to MX7G180B (ball bearing)	Reverse to motor rotational direction																									
MX7G3MA to MX7G180M (metal bearing)																										
Rotational direction																										

Permissible torque at output shaft of gear head using decimal gear head

Applicable gear head	Reduction ratio	Unit of permissible torque: upper (N·m) / lower (lb-in)															
		200	250	300	360	500	600	750	900	1000	1200	1500	1800				
Bearing	Decimal gear head																
MX7G□BA (ball bearing)	MX7G10XB	Same as motor rotational direction															
MX7G□B (bearing)		Reverse to motor rotational direction															
MX7G□MA (metal bearing)	MX7G10XB	Same as motor rotational direction															
MX7G□M (bearing)		Reverse to motor rotational direction															
Rotational direction																	

Connection diagram

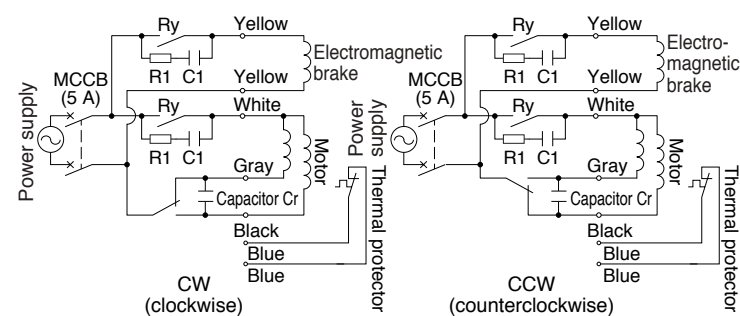

<Note>
1. Brake will be activated and held when electromagnetic brake power is turned OFF.
2. Protect the contacts by inserting the spark-killer circuit (R1+C1) between the contacts. R1+C1 is provided as an option (DV0P008A, refer to page D-3).
3. Refer to page A-58 for connection of thermal protector.
4. Use a circuit breaker for the power supply.

Speed-torque characteristics

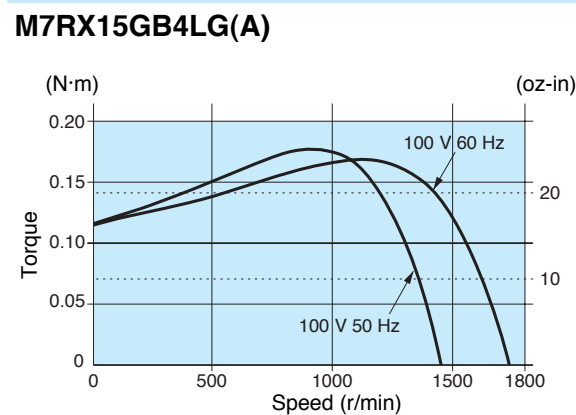

Motor (dimensions)

Scale: 1/3, Unit: mm (inch)

M7RX15GB4LG(A)	4P 15 W 100 V
M7RX15GB4DG(A)	4P 15 W 110 V / 115 V
M7RX15GB4YG(A)	4P 15 W 200 V
M7RX15GB4GG(A)	4P 15 W 220 V / 230 V

Mass	Helical gear	Module	Number of teeth
1.5 kg (3.31 lb)		0.5	7

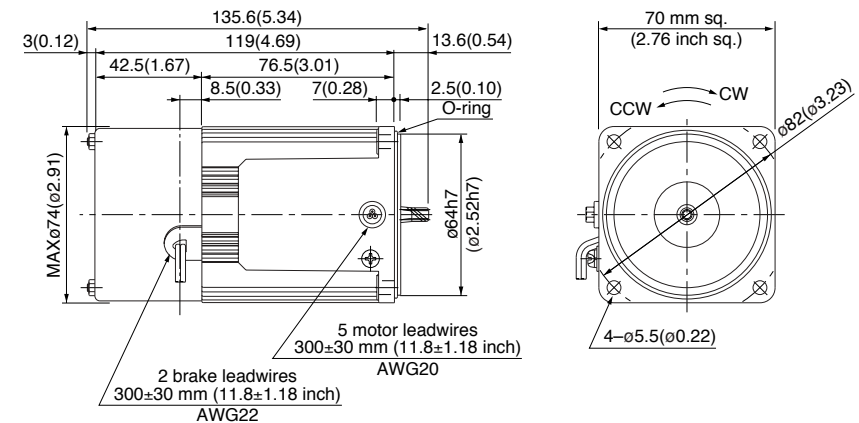

Capacitor (dimensions) [attachment]

Unit: mm (inch)

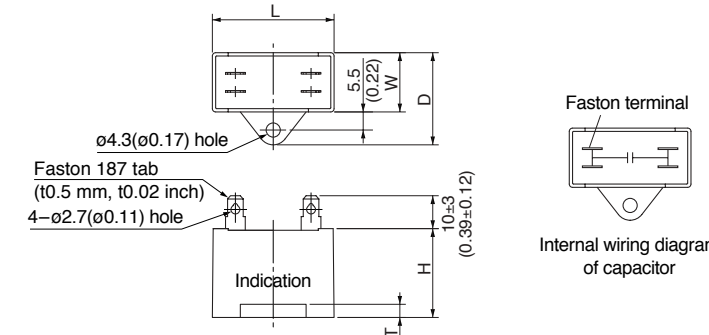

Capacitor cap (dimensions) [attachment]

Unit: mm (inch)

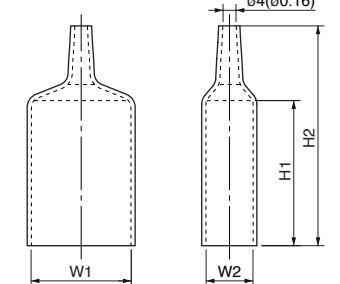

Capacitor dimension list

Unit: upper (mm) / lower (inch)

Model number of motor	Model number of capacitor (attachment)	L	W	D	H	T	Capacitor cap (attachment)	W1	W2	H1	H2
M7RX15GB4LG(A)	M0PC6.5M25G	48 (1.89)	19 (0.75)	29 (1.14)	29 (1.14)	4 (0.16)	M0PC4819G	48 (1.89)	19 (0.75)	55 (2.17)	78 (3.07)
M7RX15GB4DG(A)	M0PC5.5M25G	38 (1.50)	21 (0.83)	31 (1.22)	31 (1.22)	4 (0.16)	M0PC3821G	38 (1.50)	21 (0.83)	55 (2.17)	78 (3.07)
M7RX15GB4YG(A)	M0PC1.7M45G	38 (1.50)	21 (0.83)	31 (1.22)	31 (1.22)	4 (0.16)	M0PC3821G	38 (1.50)	21 (0.83)	55 (2.17)	78 (3.07)
M7RX15GB4GG(A)	M0PC1.3M45G	38 (1.50)	19 (0.75)	29 (1.14)	29 (1.14)	4 (0.16)	M0PC3819G	38 (1.50)	19 (0.75)	50 (1.97)	73 (2.87)

The models with a motor model number to which "A" is suffixed are not equipped with a capacitor cap.

Gear head (dimensions)

Scale: 1/3, Unit: mm (inch)

MX7G□BA (ball bearing) Mass 0.38 kg (0.84 lb)
MX7G□MA (metal bearing) Mass 0.38 kg (0.84 lb)

MX7G□B (ball bearing) Mass 0.45 kg (0.99 lb)
MX7G□M (metal bearing) Mass 0.45 kg (0.99 lb)

Key and keyway (dimensions) [attachment]

MX7G□BA(B)
MX7G□MA(M)

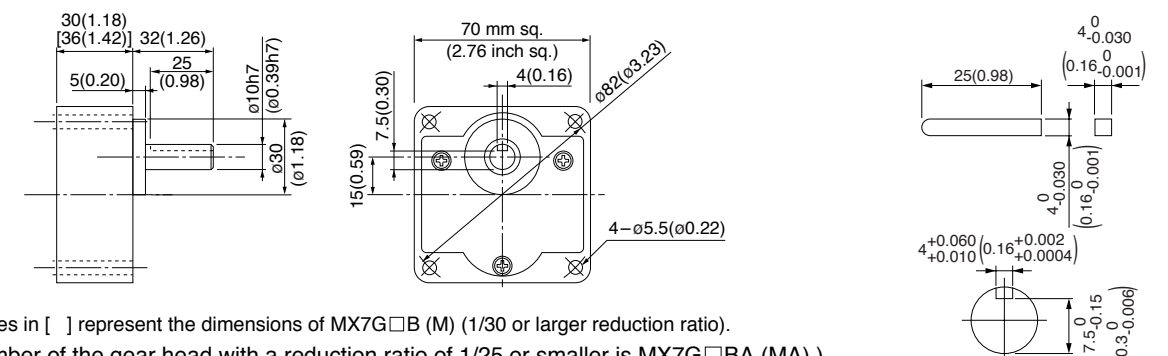

* Figures in [] represent the dimensions of MX7G□B (M) (1/30 or larger reduction ratio).
(The model number of the gear head with a reduction ratio of 1/25 or smaller is MX7G□BA (MA).)

(Note) Because the dimensions may be subject to change, also check the determinate dimensions if the gear head is to be used for design.

Electromagnetic brake single-phase motor (leadwire)

80 mm (3.15 inch) sq. 25 W

Specifications

Size	Motor model No.	Number of pole (P)	Output (W)	Voltage (V)	Frequency (Hz)	Rating (min)	Rating				Starting current (A)	Starting torque N-m (oz-in)	Brake Input (W)	Brake Current (A)	Brake Friction Torque N-m (oz-in)	Capacitor (μF) (rated voltage)
							Input (W)	Current (A)	Speed (r/min)	Torque N-m (oz-in)						
80 mm sq.	M8RX25GB4L	4	25	100	50	30	56	0.57	1300	0.19 (26.9)	1.0	0.20 (28.3)	6	0.07	0.10 (14.2)	9.5 (200 V)
						60	56	0.56	1600	0.16 (22.7)	1.0	0.20 (28.3)	6	0.07	0.10 (14.2)	
	M8RX25GB4Y	4	25	200	50	30	56	0.29	1300	0.19 (26.9)	0.52	0.20 (28.3)	6	0.03	0.10 (14.2)	2.4 (400 V)
						60	56	0.28	1600	0.16 (22.7)	0.51	0.20 (28.3)	6	0.03	0.10 (14.2)	

* The specifications and wire connections of the round shaft motor are the same as those of the pinion shaft type. For the dimensional outline drawing, refer to page B-220.

Permissible torque at output shaft of gear head

* The speed shown below is a calculated value based on the synchronous rotational speed. Depending on the load, the speed is less than the indicated value by 2% to 20%.

Unit of permissible torque: upper (N·m) / lower (lb·in)

Reduction ratio	Speed (r/min)																							
	50 Hz	60 Hz	3	3.6	5	6	7.5	9	10	12.5	15	18	20	25	30	36	50	60	75	90	100	120	150	180
Applicable gear head	Same as motor rotational direction																							
Rotational direction	Same as motor rotational direction												Reverse to motor rotational direction											

Permissible torque at output shaft of gear head using decimal gear head

Applicable gear head	Reduction ratio	Speed (r/min)															
		50 Hz	60 Hz	200	250	300	360	500	600	750	900	1000	1200	1500	1800		
Bearing	Decimal gear head	Speed (r/min)	50 Hz	60 Hz	7.5	6	5	4.2	3	2.5	2	1.7	1.5	1.3	1	0.8	
MX8G□B (ball bearing)	MX8G10XB	Permissible torque	N-m (lb-in)	7.84 (69.4)	7.84 (69.4)	7.84 (69.4)	7.84 (69.4)	7.84 (69.4)	7.84 (69.4)	7.84 (69.4)	7.84 (69.4)	7.84 (69.4)	7.84 (69.4)	7.84 (69.4)	7.84 (69.4)	7.84 (69.4)	
MX8G□M (metal bearing)			Rotational direction	Same as motor rotational direction													

Connection diagram

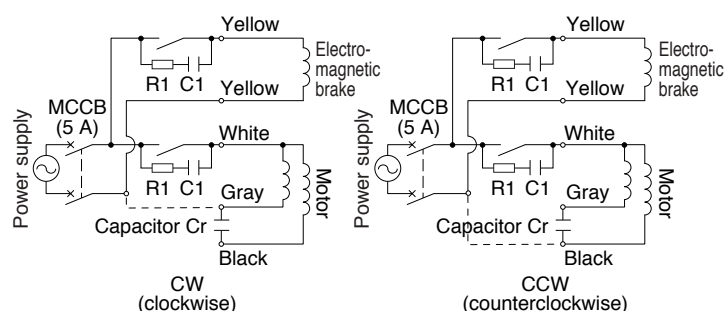

<Note>
 1. Brake will be activated and held when electromagnetic brake power is turned OFF.
 2. Protect the contacts by inserting the spark-killer circuit (R1+C1) between the contacts. R1+C1 is provided as an option (DV0P008A, refer to page D-3).
 3. Use a circuit breaker for the power supply.

Speed-torque characteristics

M8RX25GB4L

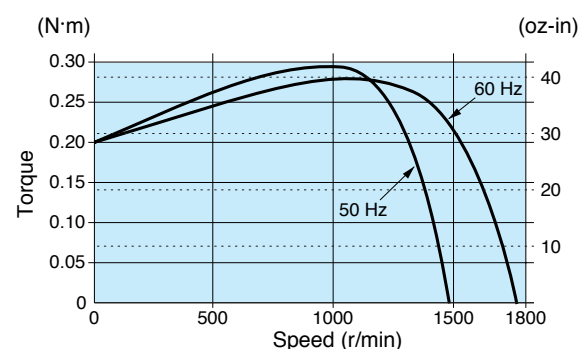

Motor (dimensions)

Scale: 1/3, Unit: mm (inch)

M8RX25GB4L 4P 25 W 100 V
 M8RX25GB4Y 4P 25 W 200 V

Mass 2.1 kg 4.63 lb
 Helical gear
 Module 0.5
 Number of teeth 9

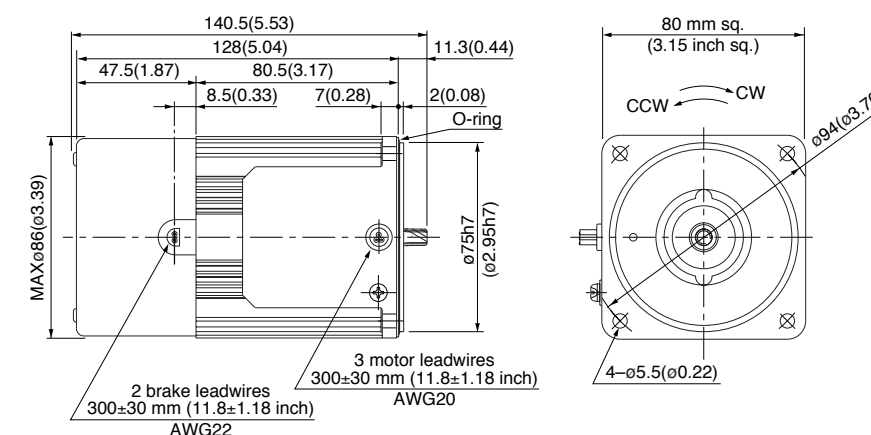

Capacitor (dimensions) [attachment]

Unit: mm (inch)

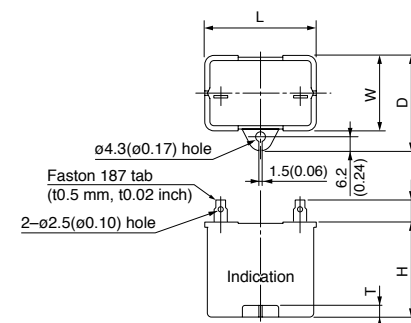

Capacitor cap (dimensions) [option]

Unit: mm (inch)

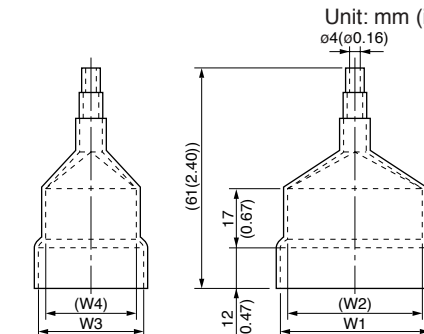

Capacitor dimension list Unit: upper (mm) / lower (inch)

Model number of motor	Model number of capacitor (attachment)	L	W	D	H	T	Capacitor cap (option)	W1	W2	W3	W4
M8RX25GB4L	M0PC9.5M20	39.5 (1.56)	22 (0.87)	32.5 (1.28)	30.5 (1.20)	4 (0.16)	M0PC3922	39.5 (1.56)	37.5 (1.48)	22 (0.87)	20 (0.79)
M8RX25GB4Y	M0PC2.4M40	49.7 (1.96)	24 (0.94)	34.5 (1.36)	34.5 (1.36)	4 (0.16)	M0PC5026	50 (1.97)	48 (1.89)	26 (1.02)	22 (0.87)

Gear head (dimensions)

Scale: 1/3, Unit: mm (inch)

MX8G□B (ball bearing) Mass 0.6 kg (1.32 lb) MX8G□M (metal bearing) Mass 0.6 kg (1.32 lb)

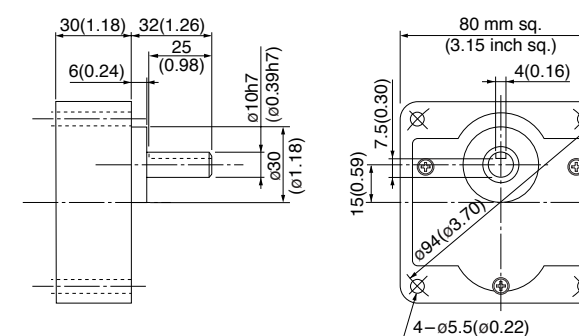

Key and keyway (dimensions) [attachment]

MX8G□B(M)

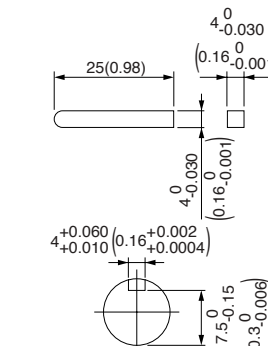

* Please read your User's manual carefully so that you will understand the operation and safety precautions before attempting to operate the system.

(Note) Because the dimensions may be subject to change, also check the determinate dimensions if the gear head is to be used for design.

Electromagnetic brake single-phase motor (leadwire)

US CE 80 mm (3.15 inch) sq. 25 W

Specifications

Size	Motor model No.	Number of pole (P)	Output (W)	Voltage (V)	Frequency (Hz)	Rating (min)	Rating				Starting current (A)	Starting torque N·m (oz-in)	Brake Input (W)	Brake Current (A)	Brake Friction Torque N·m (oz-in)	Capacitor (μF) (rated voltage)
							Input (W)	Current (A)	Speed (r/min)	Torque N·m (oz-in)						
80 mm sq.	M8RX25GB4LG M8RX25GB4LGA	4	25	100	50	30	55	0.56	1300	0.18 (25.5)	1.1	0.20 (28.3)	6	0.07	0.10 (14.2)	10
							57	0.57	1600	0.15 (21.2)	1.1	0.20 (28.3)	6	0.07	0.10 (14.2)	(250 V)
	M8RX25GB4DG M8RX25GB4DGA	4	25	110	60	30	54	0.50	1625	0.15 (21.2)	1.1	0.19 (26.9)	7	0.07	0.10 (14.2)	8
							57	0.50	1625	0.15 (21.2)	1.2	0.21 (29.7)	8	0.08	0.10 (14.2)	(250 V)
	M8RX25GB4YG M8RX25GB4YGA	4	25	200	50	30	55	0.28	1250	0.19 (26.9)	0.44	0.20 (28.3)	6	0.03	0.10 (14.2)	2.5
							64	0.33	1550	0.15 (21.2)	0.45	0.20 (28.3)	6	0.03	0.10 (14.2)	(450 V)
	M8RX25GB4GG M8RX25GB4GGA	4	25	220	60	30	56	0.26	1250	0.19 (26.9)	0.46	0.19 (26.9)	7	0.04	0.10 (14.2)	2
							57	0.26	1575	0.15 (21.2)	0.45	0.19 (26.9)	7	0.04	0.10 (14.2)	
							59	0.27	1275	0.19 (26.9)	0.48	0.21 (29.7)	8	0.04	0.10 (14.2)	
							60	0.26	1600	0.15 (21.2)	0.47	0.21 (29.7)	8	0.04	0.10 (14.2)	

The specifications and wire connections of the round shaft motor are the same as those of the pinion shaft type. For the dimensional outline drawing, refer to page B-220.
The models with a motor model number to which "A" is suffixed are not equipped with a capacitor cap.
The models with a motor model number to which "A" is suffixed are not sold or available in Japan.

Permissible torque at output shaft of gear head

The speed shown below is a calculated value based on the synchronous rotational speed. Depending on the load, the speed is less than the indicated value by 2% to 20%.

Unit of permissible torque: upper (N·m) / lower (lb-in)

Reduction ratio	Unit of permissible torque: upper (N·m) / lower (lb-in)																							
	3	3.6	5	6	7.5	9	10	12.5	15	18	20	25	30	36	50	60	75	90	100	120	150	180		
Speed (r/min)	[Data omitted for brevity]																							
Applicable gear head	[Data omitted for brevity]																							
Rotational direction	Same as motor rotational direction												Reverse to motor rotational direction											

Permissible torque at output shaft of gear head using decimal gear head

Applicable gear head	Reduction ratio	Permissible torque															
		200	250	300	360	500	600	750	900	1000	1200	1500	1800				
Bearing	Decimal gear head	Speed (r/min)	50 Hz	7.5	6	5	4.2	3	2.5	2	1.7	1.5	1.3	1	0.8		
MX8G□B (ball bearing)	MX8G10XB	Permissible torque (lb-in)	60 Hz	9	7.2	6	5	3.6	3	2.4	2	1.8	1.5	1.2	1		
MX8G□M (metal bearing)			Rotational direction	Same as motor rotational direction / Reverse to motor rotational direction													

Connection diagram

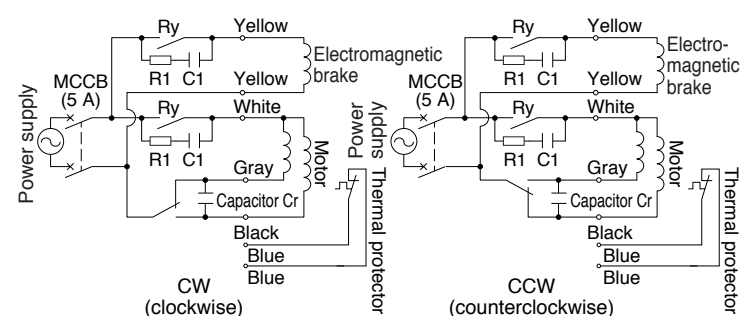

<Note>
1. Brake will be activated and held when electromagnetic brake power is turned OFF.
2. Protect the contacts by inserting the spark-killer circuit (R1+C1) between the contacts. R1+C1 is provided as an option (DV0P008A, refer to page D-3).
3. Refer to page A-58 for connection of thermal protector.
4. Use a circuit breaker for the power supply.

Speed-torque characteristics

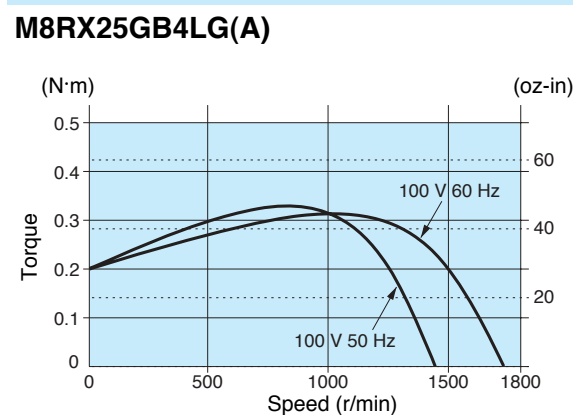

Motor (dimensions)

Scale: 1/3, Unit: mm (inch)

M8RX25GB4LG(A)	4P 25 W 100 V
M8RX25GB4DG(A)	4P 25 W 110 V / 115 V
M8RX25GB4YG(A)	4P 25 W 200 V
M8RX25GB4GG(A)	4P 25 W 220 V / 230 V

Mass	Helical gear	Module	Number of teeth
2.1 kg 4.63 lb		0.5	9

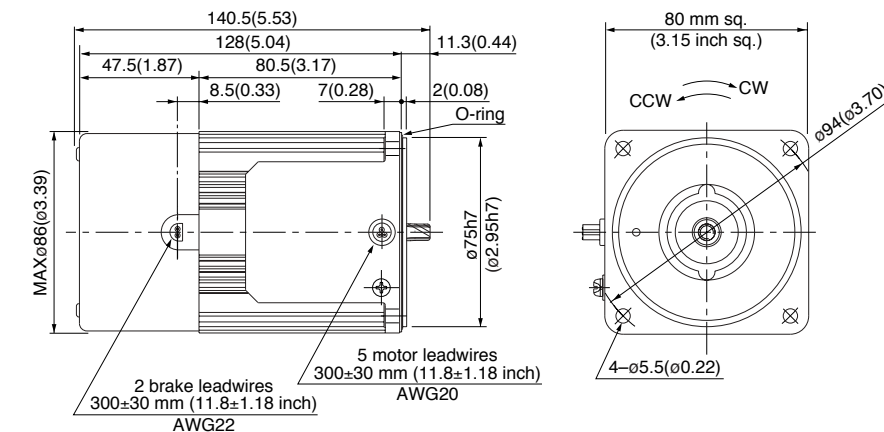

Capacitor (dimensions) [attachment]

Unit: mm (inch)

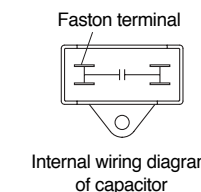
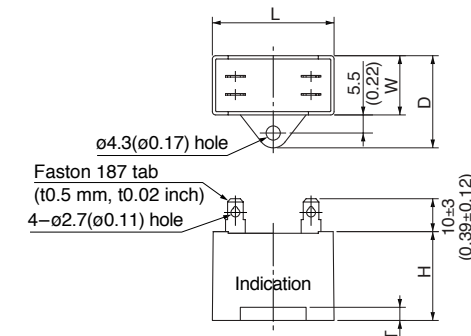

Capacitor cap (dimensions) [attachment]

Unit: mm (inch)

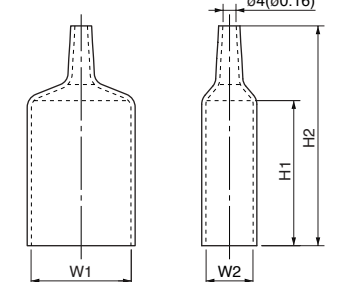

Capacitor dimension list Unit: upper (mm) / lower (inch)

Model number of motor	Model number of capacitor (attachment)	L	W	D	H	T	Capacitor cap (attachment)	W1	W2	H1	H2
M8RX25GB4LG(A)	M0PC10M25G	58 (2.28)	21 (0.83)	31 (1.22)	31 (1.22)	4 (0.16)	M0PC5821G	58 (2.28)	21 (0.83)	55 (2.17)	78 (3.07)
M8RX25GB4DG(A)	M0PC8M25G	48 (1.89)	21 (0.83)	31 (1.22)	31 (1.22)	4 (0.16)	M0PC4821G	48 (1.89)	21 (0.83)	55 (2.17)	78 (3.07)
M8RX25GB4YG(A)	M0PC2.5M45G	48 (1.89)	21 (0.83)	31 (1.22)	31 (1.22)	4 (0.16)	M0PC4821G	48 (1.89)	21 (0.83)	55 (2.17)	78 (3.07)
M8RX25GB4GG(A)	M0PC2M45G	48 (1.89)	19 (0.75)	29 (1.14)	29 (1.14)	4 (0.16)	M0PC4819G	48 (1.89)	19 (0.75)	55 (2.17)	78 (3.07)

The models with a motor model number to which "A" is suffixed are not equipped with a capacitor cap.

Gear head (dimensions)

Scale: 1/3, Unit: mm (inch)

MX8G□B (ball bearing) Mass 0.6 kg (1.32 lb) MX8G□M (metal bearing) Mass 0.6 kg (1.32 lb)

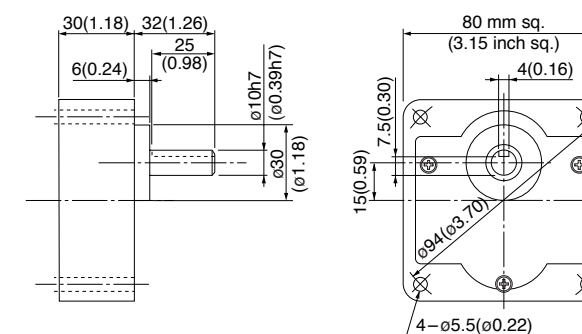

Key and keyway (dimensions) [attachment]

MX8G□B(M)

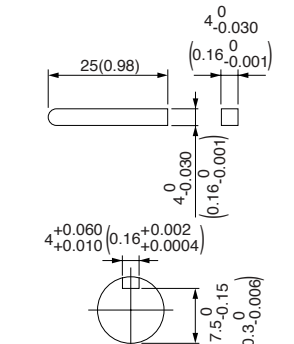

Please read your User's manual carefully so that you will understand the operation and safety precautions before attempting to operate the system.

(Note) Because the dimensions may be subject to change, also check the determinate dimensions if the gear head is to be used for design.

Electromagnetic brake single-phase motor (leadwire)

90 mm (3.54 inch) sq. 40 W

Specifications

Size	Motor model No.	Number of pole (P)	Output (W)	Voltage (V)	Frequency (Hz)	Rating (min)	Rating				Starting current (A)	Starting torque N·m (oz-in)	Brake Input (W)	Brake Current (A)	Brake Friction Torque N·m (oz-in)	Capacitor (μF) (rated voltage)
							Input (W)	Current (A)	Speed (r/min)	Torque N·m (oz-in)						
90 mm sq.	M9RX40GB4L	4	40	100	50	30	79	0.81	1300	0.29 (41.1)	1.7	0.32 (45.3)	9	0.10	0.20 (28.3)	15 (210 V)
							80	0.81	1625	0.24 (34.0)	1.6	0.32 (45.3)	9	0.10	0.20 (28.3)	
	M9RX40GB4Y	4	40	200	50	30	79	0.40	1300	0.29 (41.1)	0.85	0.32 (45.3)	9	0.05	0.20 (28.3)	3.8 (400 V)
							80	0.41	1625	0.24 (34.0)	0.78	0.32 (45.3)	9	0.05	0.20 (28.3)	

* The specifications and wire connections of the round shaft motor are the same as those of the pinion shaft type. For the dimensional outline drawing, refer to page B-220.

Permissible torque at output shaft of gear head

* The speed shown below is a calculated value based on the synchronous rotational speed. Depending on the load, the speed is less than the indicated value by 2 % to 20 %.

Unit of permissible torque: upper (N·m) / lower (lb-in)

Reduction ratio	Speed (r/min)																							
	50 Hz	60 Hz	3	3.6	5	6	7.5	9	10	12.5	15	18	20	25	30	36	50	60	75	90	100	120	150	180
Applicable gear head	MX9G3B to MX9G180B (ball bearing)												MX9G3M to MX9G180M (metal bearing)											
Rotational direction	Same as motor rotational direction												Reverse to motor rotational direction											

Permissible torque at output shaft of gear head using decimal gear head

Applicable gear head	Reduction ratio	Speed (r/min)															
		50 Hz	60 Hz	200	250	300	360	500	600	750	900	1000	1200	1500	1800		
Bearing	Decimal gear head	Speed (r/min)	50 Hz	60 Hz	7.5	6	5	4.2	3	2.5	2	1.7	1.5	1.3	1	0.8	
MX9G□B (ball bearing)	MX9G10XB	Permissible torque	N·m (lb-in)	9.80 (86.7)	9.80 (86.7)	9.80 (86.7)	9.80 (86.7)	9.80 (86.7)	9.80 (86.7)	9.80 (86.7)	9.80 (86.7)	9.80 (86.7)	9.80 (86.7)	9.80 (86.7)	9.80 (86.7)	9.80 (86.7)	
MX9G□M (metal bearing)			Rotational direction	Same as motor rotational direction		Reverse to motor rotational direction											

Connection diagram

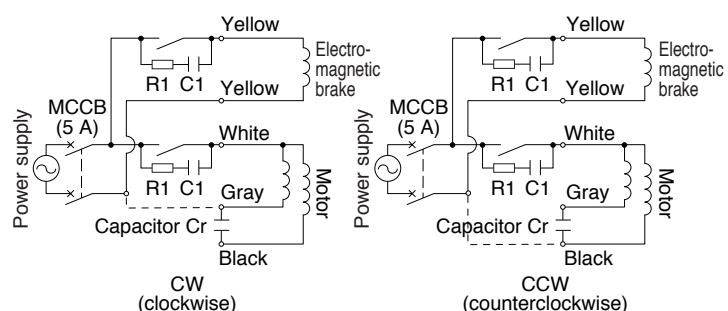

<Note>
 1. Brake will be activated and held when electromagnetic brake power is turned OFF.
 2. Protect the contacts by inserting the spark-killer circuit (R1+C1) between the contacts. R1+C1 is provided as an option (DV0P008A, refer to page D-3).
 3. Use a circuit breaker for the power supply.

Speed-torque characteristics

M9RX40GB4L

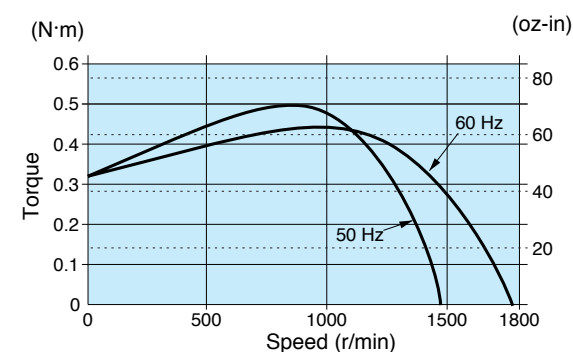

Motor (dimensions)

Scale: 1/3, Unit: mm (inch)

M9RX40GB4L 4P 40 W 100 V
 M9RX40GB4Y 4P 40 W 200 V

Mass 3.2 kg 7.05 lb
 Helical gear
 Module 0.55
 Number of teeth 9

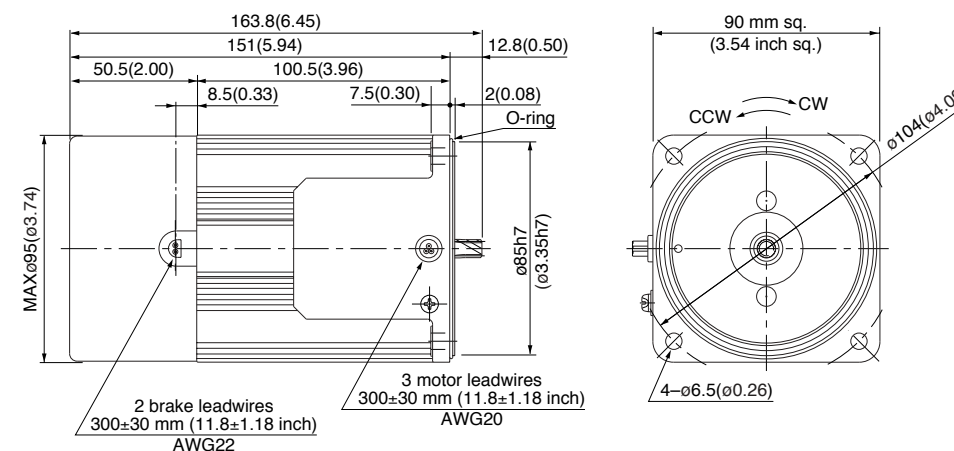

Capacitor (dimensions) [attachment]

Unit: mm (inch)

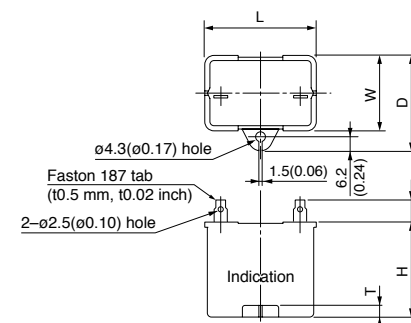

Capacitor cap (dimensions) [option]

Unit: mm (inch)

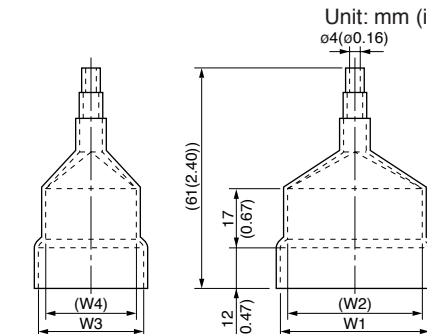

Capacitor dimension list Unit: upper (mm) / lower (inch)

Model number of motor	Model number of capacitor (attachment)	L	W	D	H	T	Capacitor cap (option)	W1	W2	W3	W4
M9RX40GB4L	M0PC15M20	39.5 (1.56)	26.7 (1.05)	37 (1.46)	41 (1.61)	4 (0.16)	M0PC3926	39.5 (1.56)	37.5 (1.48)	26 (1.02)	25 (0.98)
M9RX40GB4Y	M0PC3.8M40	50 (1.97)	26.7 (1.05)	37.5 (1.48)	38 (1.50)	4 (0.16)	M0PC5026	50 (1.97)	48 (1.89)	26 (1.02)	22 (0.87)

Gear head (dimensions)

Scale: 1/3, Unit: mm (inch)

MX9G□B (ball bearing) Mass 0.8 kg (1.76 lb) MX9G□M (metal bearing) Mass 0.8 kg (1.76 lb)

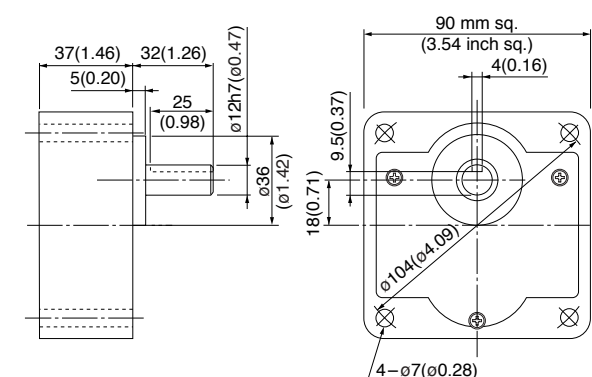

Key and keyway (dimensions) [attachment]

MX9G□B(M)

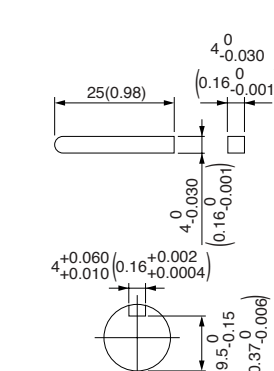

* Please read your User's manual carefully so that you will understand the operation and safety precautions before attempting to operate the system.

(Note) Because the dimensions may be subject to change, also check the determinate dimensions if the gear head is to be used for design.

Electromagnetic brake single-phase motor (leadwire)

US CE 90 mm (3.54 inch) sq. 40 W

Specifications

Size	Motor model No.	Number of pole (P)	Output (W)	Voltage (V)	Frequency (Hz)	Rating (min)	Rating				Starting current (A)	Starting torque N·m (oz-in)	Brake Input (W)	Brake Current (A)	Brake Friction Torque N·m (oz-in)	Capacitor (μF) (rated voltage)
							Input (W)	Current (A)	Speed (r/min)	Torque N·m (oz-in)						
90 mm sq.	M9RX40GB4LG M9RX40GB4LGA	4	40	100	50	30	76	0.77	1325	0.29 (41.1)	1.7	0.34 (48.1)	9	0.10	0.20 (28.3)	16 (250 V)
							83	0.86	1625	0.24 (34.0)	1.7	0.34 (48.1)	9	0.10	0.20 (28.3)	
	M9RX40GB4DG M9RX40GB4DGA	4	40	110	60	30	77	0.70	1650	0.23 (32.6)	1.7	0.32 (45.3)	11	0.11	0.20 (28.3)	12 (250 V)
							80	0.70	1650	0.23 (32.6)	1.8	0.34 (48.1)	11	0.12	0.20 (28.3)	
	M9RX40GB4YG M9RX40GB4YGA	4	40	200	50	30	81	0.40	1275	0.30 (42.5)	0.69	0.34 (48.1)	9	0.05	0.20 (28.3)	4 (450 V)
							103	0.54	1575	0.24 (34.0)	0.71	0.34 (48.1)	9	0.05	0.20 (28.3)	
	M9RX40GB4GG M9RX40GB4GGA	4	40	220	60	30	80	0.36	1325	0.29 (41.1)	0.73	0.39 (55.2)	11	0.06	0.20 (28.3)	3.5 (450 V)
							96	0.46	1625	0.24 (34.0)	0.73	0.39 (55.2)	11	0.06	0.20 (28.3)	

The specifications and wire connections of the round shaft motor are the same as those of the pinion shaft type. For the dimensional outline drawing, refer to page B-220.
The models with a motor model number to which "A" is suffixed are not equipped with a capacitor cap.
The models with a motor model number to which "A" is suffixed are not sold or available in Japan.

Permissible torque at output shaft of gear head

The speed shown below is a calculated value based on the synchronous rotational speed. Depending on the load, the speed is less than the indicated value by 2% to 20%.

Unit of permissible torque: upper (N·m) / lower (lb-in)

Reduction ratio	Unit of permissible torque: upper (N·m) / lower (lb-in)																							
	3	3.6	5	6	7.5	9	10	12.5	15	18	20	25	30	36	50	60	75	90	100	120	150	180		
Speed (r/min)	50 Hz		500	416.7	300	250	200	166.7	150	120	100	83.3	75	60	50	41.7	30	25	20	16.7	15	12.5	10	8.3
	60 Hz		600	500	360	300	240	200	180	144	120	100	90	72	60	50	36	30	24	20	18	15	12	10
Applicable gear head	MX9G3B to MX9G180B (ball bearing)	50 Hz	0.66 (5.84)	0.78 (6.90)	1.08 (9.56)	1.27 (11.2)	1.57 (13.9)	1.86 (16.5)	2.25 (19.9)	2.74 (24.3)	3.23 (28.6)	3.92 (34.7)	4.41 (39.0)	5.29 (46.8)	6.37 (56.4)	7.94 (70.3)	9.80 (86.7)							
		60 Hz	0.55 (4.87)	0.66 (5.84)	0.90 (7.97)	1.08 (9.56)	1.27 (11.2)	1.57 (13.9)	1.76 (15.6)	2.25 (19.9)	2.74 (24.3)	3.23 (28.6)	3.53 (31.2)	4.41 (39.0)	5.29 (46.8)	6.37 (56.4)	8.82 (78.1)	9.80 (86.7)						
Rotational direction		Same as motor rotational direction											Reverse to motor rotational direction											

Permissible torque at output shaft of gear head using decimal gear head

Applicable gear head	Reduction ratio	Permissible torque																
		200	250	300	360	500	600	750	900	1000	1200	1500	1800					
Bearing	Decimal gear head	Speed (r/min)																
		50 Hz	7.5	6	5	4.2	3	2.5	2	1.7	1.5	1.3	1	0.8				
		60 Hz	9	7.2	6	5	3.6	3	2.4	2	1.8	1.5	1.2	1				
MX9G□B (ball bearing) MX9G□M (metal bearing)	MX9G10XB	Permissible torque	N·m (lb-in)	9.80 (86.7)	9.80 (86.7)	9.80 (86.7)	9.80 (86.7)	9.80 (86.7)	9.80 (86.7)	9.80 (86.7)	9.80 (86.7)	9.80 (86.7)	9.80 (86.7)	9.80 (86.7)	9.80 (86.7)	9.80 (86.7)		
		Rotational direction	Same as motor rotational direction			Reverse to motor rotational direction												

Connection diagram

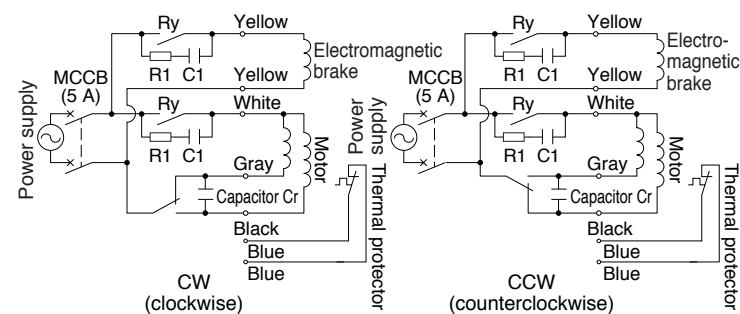

<Note>
1. Brake will be activated and held when electromagnetic brake power is turned OFF.
2. Protect the contacts by inserting the spark-killer circuit (R1+C1) between the contacts. R1+C1 is provided as an option (DV0P008A, refer to page D-3).
3. Refer to page A-58 for connection of thermal protector.
4. Use a circuit breaker for the power supply.

Speed-torque characteristics

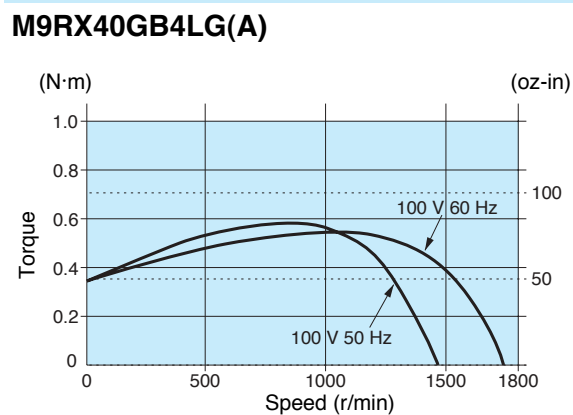

Motor (dimensions)

Scale: 1/3, Unit: mm (inch)

M9RX40GB4LG(A)	4P 40 W 100 V
M9RX40GB4DG(A)	4P 40 W 110 V / 115 V
M9RX40GB4YG(A)	4P 40 W 200 V
M9RX40GB4GG(A)	4P 40 W 220 V / 230 V

Mass	Helical gear	Module	Number of teeth
3.2 kg (7.05 lb)		0.55	9

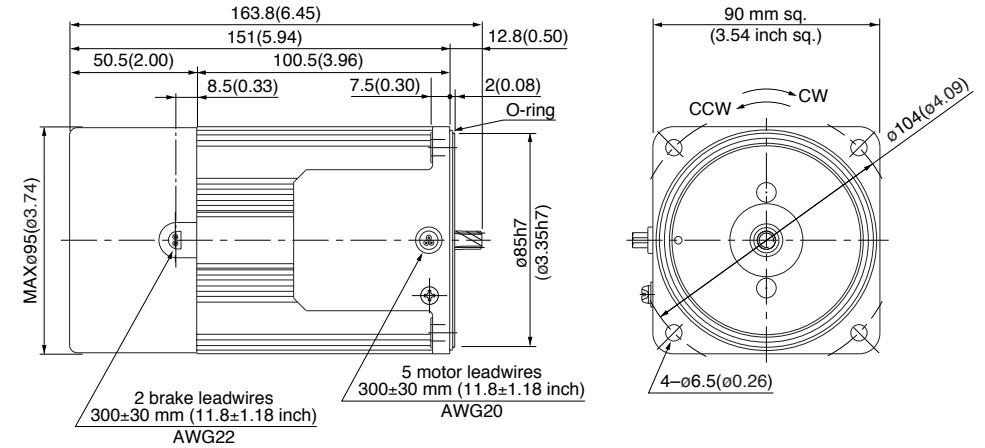

Capacitor (dimensions) [attachment]

Unit: mm (inch)

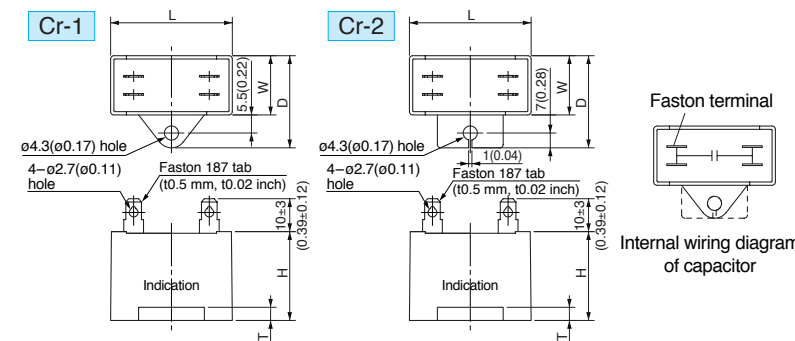

Capacitor cap (dimensions) [attachment]

Unit: mm (inch)

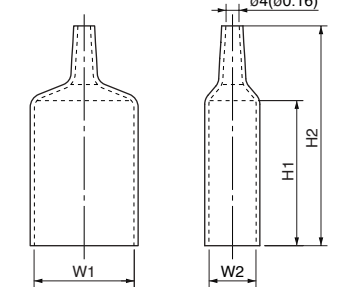

Capacitor dimension list Unit: upper (mm) / lower (inch)

Model number of motor	Model number of capacitor (attachment)	L	W	D	H	T	dimension No.	Capacitor cap (attachment)	W1	W2	H1	H2
M9RX40GB4LG(A)	M0PC16M25G	58 (2.28)	23.5 (0.93)	38.5 (1.52)	37 (1.46)	4 (0.16)	Cr-2	M0PC5823G	58 (2.28)	23.5 (0.93)	55 (2.17)	78 (3.07)
M9RX40GB4DG(A)	M0PC12M25G	58 (2.28)	22 (0.87)	32 (1.26)	35 (1.38)	4 (0.16)	Cr-1	M0PC5822G	58 (2.28)	22 (0.87)	55 (2.17)	78 (3.07)
M9RX40GB4YG(A)	M0PC4M45G	58 (2.28)	23.5 (0.93)	38.5 (1.52)	37 (1.46)	4 (0.16)	Cr-2	M0PC5823G	58 (2.28)	23.5 (0.93)	55 (2.17)	78 (3.07)
M9RX40GB4GG(A)	M0PC3.5M45G	58 (2.28)	22 (0.87)	32 (1.26)	35 (1.38)	4 (0.16)	Cr-1	M0PC5822G	58 (2.28)	22 (0.87)	55 (2.17)	78 (3.07)

The models with a motor model number to which "A" is suffixed are not equipped with a capacitor cap.

Gear head (dimensions)

Scale: 1/3, Unit: mm (inch)

MX9G□B (ball bearing) Mass 0.8 kg (1.76 lb) MX9G□M (metal bearing) Mass 0.8 kg (1.76 lb)

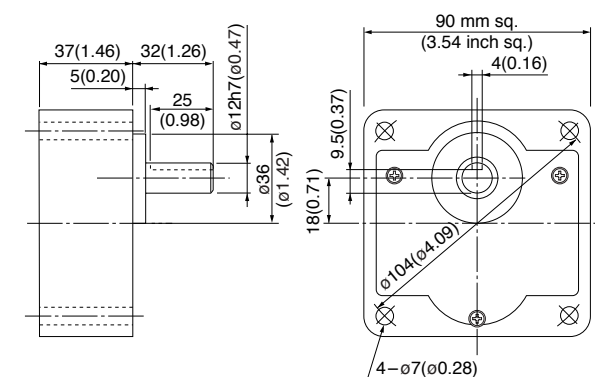

Key and keyway (dimensions) [attachment]

MX9G□B(M)

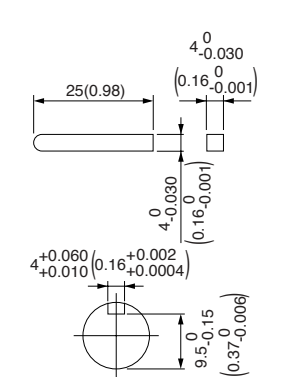

* Please read your User's manual carefully so that you will understand the operation and safety precautions before attempting to operate the system.

(Note) Because the dimensions may be subject to change, also check the determinate dimensions if the gear head is to be used for design.

Electromagnetic brake single-phase motor (leadwire)

90 mm (3.54 inch) sq. 60 W

Specifications

Size	Motor model No.	Number of pole (P)	Output (W)	Voltage (V)	Frequency (Hz)	Rating (min)	Rating				Starting current (A)	Starting torque N·m (oz-in)	Brake Input (W)	Brake Current (A)	Brake Friction Torque N·m (oz-in)	Capacitor (μF) (rated voltage)
							Input (W)	Current (A)	Speed (r/min)	Torque N·m (oz-in)						
90 mm sq.	M9RZ60GB4L	4	60	100	50	30	127	1.3	1275	0.45 (63.7)	2.4	0.57 (80.7)	9	0.10	0.39 (55.2)	25 (200 V)
							133	1.3	1600	0.36 (51.0)	2.4	0.57 (80.7)	9	0.10	0.39 (55.2)	
	M9RZ60GB4Y	4	60	200	50	30	127	0.65	1275	0.45 (63.7)	1.2	0.57 (80.7)	9	0.05	0.39 (55.2)	6.2 (375 V)
							133	0.65	1600	0.36 (51.0)	1.2	0.57 (80.7)	9	0.05	0.39 (55.2)	

* The specifications and wire connections of the round shaft motor are the same as those of the pinion shaft type. For the dimensional outline drawing, refer to page B-220.

Permissible torque at output shaft of gear head

* The speed shown below is a calculated value based on the synchronous rotational speed. Depending on the load, the speed is less than the indicated value by 2 % to 20 %.

Unit of permissible torque: upper (N·m) / lower (lb-in)

Reduction ratio	Speed (r/min)																										
	50 Hz	60 Hz	3	3.6	5	6	7.5	9	10	12.5	15	18	20	25	30	36	50	60	75	90	100	120	150	180	200		
50 Hz	0.98 (8.7)	1.18 (10.4)	1.57 (13.9)	1.96 (17.3)	2.35 (20.8)	2.94 (26.0)	3.14 (27.8)	3.92 (34.7)	4.70 (41.6)	5.59 (49.5)	6.27 (55.5)	7.55 (66.8)	9.11 (80.6)	11.0 (97.4)	15.2 (135)	17.8 (158)											19.6 (173)
60 Hz	0.78 (6.9)	0.98 (8.7)	1.37 (12.1)	1.57 (13.9)	1.96 (17.3)	2.35 (20.8)	2.65 (23.5)	3.33 (29.5)	3.92 (34.7)	4.70 (41.8)	5.29 (46.8)	6.47 (57.3)	7.55 (66.8)	9.11 (80.6)	12.6 (112)	15.2 (135)											19.6 (173)

Applicable gear head: MZ9G3B to MZ9G200B (ball bearing / hinge not attached), MY9G3B to MY9G200B (ball bearing / hinge attached)

Rotational direction: Same as motor rotational direction, Reverse to motor rotational direction, Same as motor rotational direction

Permissible torque at output shaft of gear head using decimal gear head

Applicable gear head		Reduction ratio	Speed (r/min)															
Bearing	Decimal gear head		50 Hz	60 Hz	6	5	4.2	3	2.5	2	1.7	1.5	1.3	1	0.8			
MZ9G□B (ball bearing / Hinge not attached)	MZ9G10XB	Permissible torque	N·m (lb-in)	19.6 (173)	19.6 (173)	19.6 (173)	19.6 (173)	19.6 (173)	19.6 (173)	19.6 (173)	19.6 (173)	19.6 (173)	19.6 (173)	19.6 (173)	19.6 (173)	19.6 (173)		
MY9G□B (ball bearing / Hinge attached)			Rotational direction	Reverse to motor rotational direction	Same as motor rotational direction													

Connection diagram

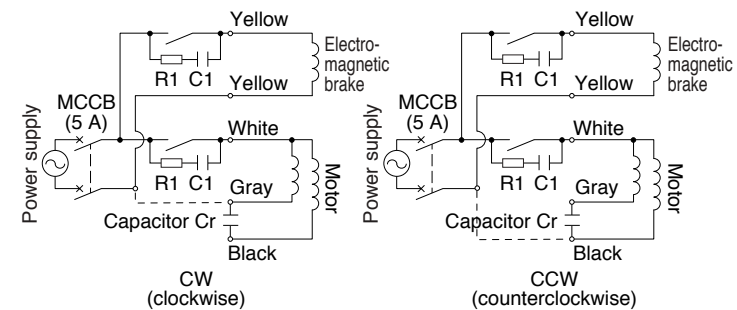

<Note>
 1. Brake will be activated and held when electromagnetic brake power is turned OFF.
 2. Protect the contacts by inserting the spark-killer circuit (R1+C1) between the contacts. R1+C1 is provided as an option (DV0P008A, refer to page D-3).
 3. Use a circuit breaker for the power supply.

Speed-torque characteristics

M9RZ60GB4L

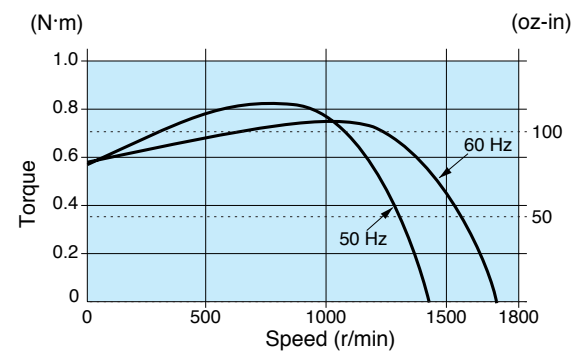

Motor (dimensions)

Scale: 1/4, Unit: mm (inch)

M9RZ60GB4L 4P 60 W 100 V (with fan)
 M9RZ60GB4Y 4P 60 W 200 V (with fan)

Mass 3.4 kg (7.50 lb)
 Helical gear
 Module 0.6
 Number of teeth 9

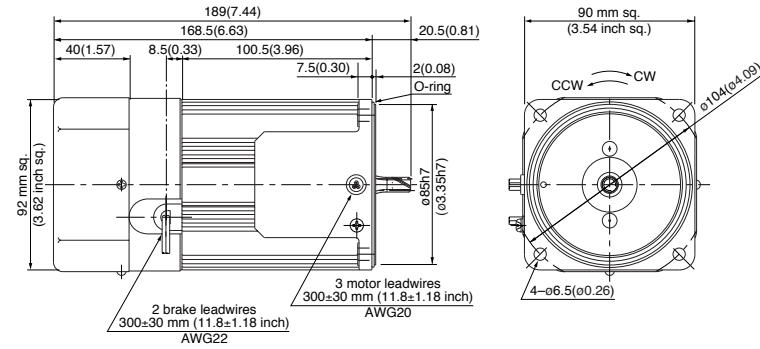

Capacitor (dimensions) [attachment]

Unit: mm (inch)

Capacitor cap (dimensions) [option]

Unit: mm (inch)

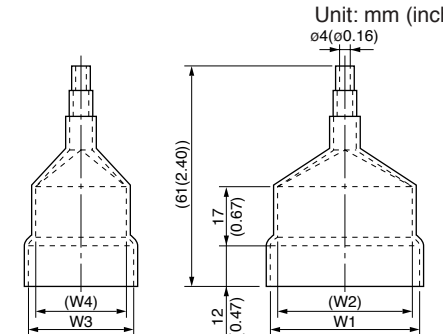
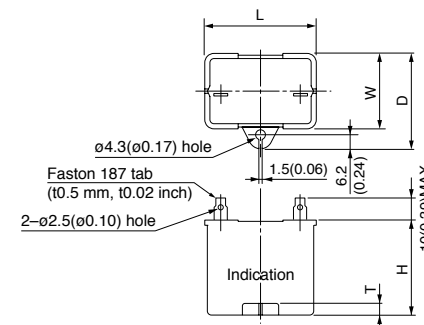

Capacitor dimension list Unit: upper (mm) / lower (inch)

Model number of motor	Model number of capacitor (attachment)	L	W	D	H	T	Capacitor cap (option)	W1	W2	W3	W4
M9RZ60GB4L	M0PC25M20	50.2 (1.98)	31 (1.22)	41 (1.61)	42 (1.65)	5 (0.20)	M0PC5032	50 (1.97)	48 (1.89)	32.5 (1.28)	29.5 (1.16)
M9RZ60GB4Y	M0PC6.2M38	50 (1.97)	30.5 (1.20)	41 (1.61)	41.5 (1.63)	4 (0.16)	M0PC5032	50 (1.97)	48 (1.89)	32.5 (1.28)	29.5 (1.16)

Gear head (dimensions)

Scale: 1/4, Unit: mm (inch)

MZ9G□B (ball bearing / hinge not attached)
 Mass 1.4 kg (3.09 lb)

MY9G□B (ball bearing / hinge attached)
 Mass 1.4 kg (3.09 lb)

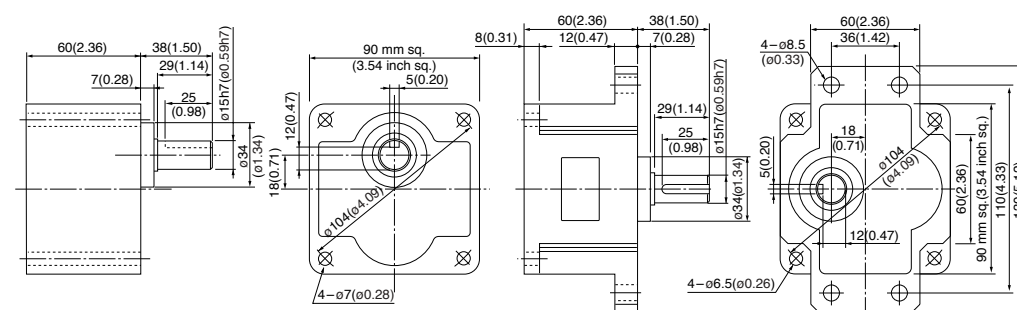

Key and keyway (dimensions) [attachment]

MZ9G□B
 MY9G□B

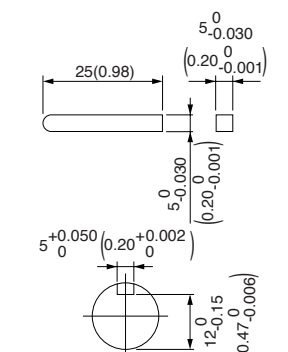

Note) MZ / MY is available for a gear head of either type.

(Note) Because the dimensions may be subject to change, also check the determinate dimensions if the gear head is to be used for design.

Electromagnetic brake single-phase motor (leadwire)

US CE 90 mm (3.54 inch) sq. 60 W

Specifications

Size	Motor model No.	Number of pole (P)	Output (W)	Voltage (V)	Frequency (Hz)	Rating (min)	Rating				Starting current (A)	Starting torque N·m (oz-in)	Brake Input (W)	Brake Current (A)	Brake Friction Torque N·m (oz-in)	Capacitor (μF) (rated voltage)
							Input (W)	Current (A)	Speed (r/min)	Torque N·m (oz-in)						
90 mm sq.	M9RZ60GB4LG(A) M9RZ60GB4LGA	4	60	100	50	30	126	1.3	1300	0.44 (62.3)	2.5	0.57 (80.7)	9	0.10	0.39 (55.2)	25
							134	1.4	1600	0.36 (51.0)	2.4	0.57 (80.7)	9	0.10	0.39 (55.2)	(250 V)
	M9RZ60GB4DG(A) M9RZ60GB4DGA	4	60	110	60	30	127	1.2	1625	0.35 (49.6)	2.5	0.56 (79.3)	11	0.11	0.39 (55.2)	20
							134	1.2	1650	0.35 (49.6)	2.6	0.62 (87.8)	11	0.12	0.39 (55.2)	(250 V)
	M9RZ60GB4YG(A) M9RZ60GB4YGA	4	60	200	50	30	121	0.60	1275	0.45 (63.7)	1.1	0.57 (80.7)	9	0.05	0.39 (55.2)	6
							146	0.76	1575	0.36 (51.0)	1.1	0.57 (80.7)	9	0.05	0.39 (55.2)	(450 V)
	M9RZ60GB4GG(A) M9RZ60GB4GGA	4	60	220	60	30	126	0.59	1300	0.44 (62.3)	1.1	0.56 (79.3)	11	0.06	0.39 (55.2)	5
							133	0.62	1600	0.36 (51.0)	1.1	0.57 (80.7)	11	0.06	0.39 (55.2)	(450 V)
							135	0.62	1300	0.44 (62.3)	1.2	0.62 (87.8)	12	0.06	0.39 (55.2)	
							139	0.61	1625	0.35 (49.6)	1.1	0.62 (87.8)	12	0.06	0.39 (55.2)	

The specifications and wire connections of the round shaft motor are the same as those of the pinion shaft type. For the dimensional outline drawing, refer to page B-220.
The models with a motor model number to which "A" is suffixed are not equipped with a capacitor cap.
The models with a motor model number to which "A" is suffixed are not sold or available in Japan.

Permissible torque at output shaft of gear head

The speed shown below is a calculated value based on the synchronous rotational speed. Depending on the load, the speed is less than the indicated value by 2% to 20%.

Unit of permissible torque: upper (N·m) / lower (lb-in)

Reduction ratio	Speed (r/min)																							
	3	3.6	5	6	7.5	9	10	12.5	15	18	20	25	30	36	50	60	75	90	100	120	150	180	200	
Speed (r/min)	50 Hz																							
	60 Hz																							
Applicable gear head	MZ9G3B to MZ9G200B (ball bearing / hinge not attached)												MY9G3B to MY9G200B (ball bearing / hinge attached)											
	50 Hz												60 Hz											
Rotational direction	Same as motor rotational direction												Reverse to motor rotational direction											

Permissible torque at output shaft of gear head using decimal gear head

Applicable gear head	Reduction ratio	Speed (r/min)															
		250	300	360	500	600	750	900	1000	1200	1500	1800					
Bearing	Decimal gear head	Speed (r/min)															
		50 Hz		60 Hz		50 Hz		60 Hz		50 Hz		60 Hz		50 Hz		60 Hz	
MZ9G□B (ball bearing / hinge not attached) MY9G□B (ball bearing / hinge attached)	MZ9G10XB	Permissible torque	N·m (lb-in)	19.6 (173)	19.6 (173)	19.6 (173)	19.6 (173)	19.6 (173)	19.6 (173)	19.6 (173)	19.6 (173)	19.6 (173)	19.6 (173)	19.6 (173)	19.6 (173)	19.6 (173)	19.6 (173)
		Rotational direction	Reverse to motor rotational direction		Same as motor rotational direction												

Connection diagram

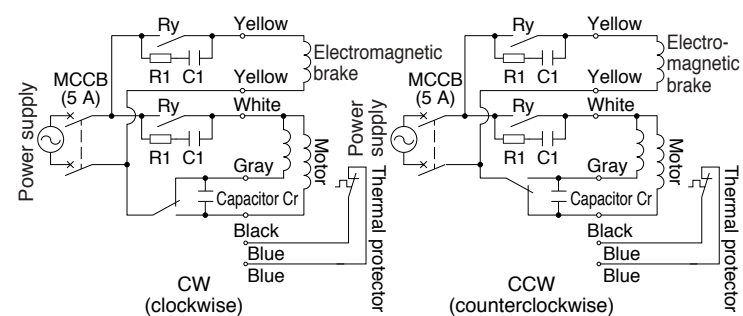

<Note>
1. Brake will be activated and held when electromagnetic brake power is turned OFF.
2. Protect the contacts by inserting the spark-killer circuit (R1+C1) between the contacts. R1+C1 is provided as an option (DV0P008A, refer to page D-3).
3. Refer to page A-58 for connection of thermal protector.
4. Use a circuit breaker for the power supply.

Speed-torque characteristics

M9RZ60GB4LG(A)

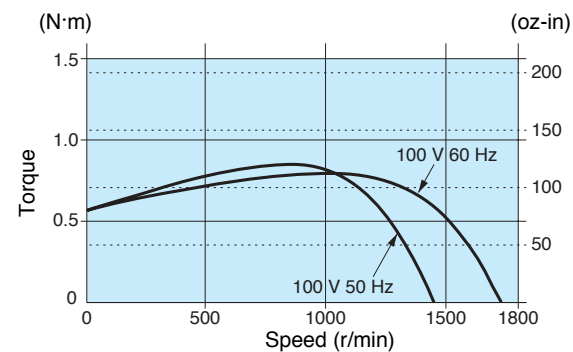

Motor (dimensions)

Scale: 1/4, Unit: mm (inch)

M9RZ60GB4LG(A)	4P 60 W 100 V (with fan)
M9RZ60GB4DG(A)	4P 60 W 110 V / 115 V (with fan)
M9RZ60GB4YG(A)	4P 60 W 200 V (with fan)
M9RZ60GB4GG(A)	4P 60 W 220 V / 230 V (with fan)

Mass 3.4 kg 7.50 lb
Helical gear
Module 0.6
Number of teeth 9

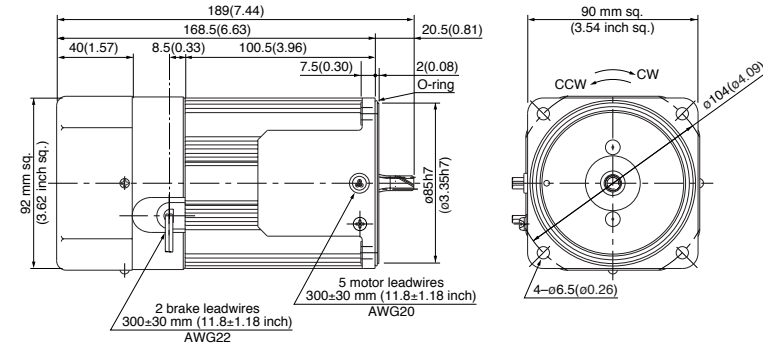

Capacitor (dimensions) [attachment]

Unit: mm (inch)

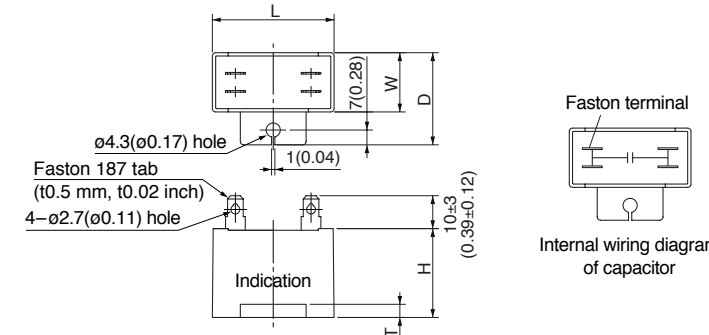

Capacitor cap (dimensions) [attachment]

Unit: mm (inch)

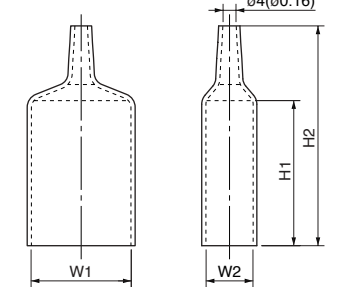

Capacitor dimension list

Unit: upper (mm) / lower (inch)

Model number of motor	Model number of capacitor (attachment)	L	W	D	H	T	Capacitor cap (attachment)	W1	W2	H1	H2
M9RZ60GB4LG(A)	M0PC25M25G	58 (2.28)	35 (1.38)	50 (1.97)	50 (1.97)	4 (0.16)	M0PC5835G	58 (2.28)	35 (1.38)	55 (2.17)	78 (3.07)
M9RZ60GB4DG(A)	M0PC20M25G	58 (2.28)	29 (1.14)	44 (1.73)	41 (1.61)	4 (0.16)	M0PC5829G	58 (2.28)	29 (1.14)	55 (2.17)	78 (3.07)
M9RZ60GB4YG(A)	M0PC6M45G	58 (2.28)	29 (1.14)	44 (1.73)	41 (1.61)	4 (0.16)	M0PC5829G	58 (2.28)	29 (1.14)	55 (2.17)	78 (3.07)
M9RZ60GB4GG(A)	M0PC5M45G	58 (2.28)	29 (1.14)	44 (1.73)	41 (1.61)	4 (0.16)	M0PC5829G	58 (2.28)	29 (1.14)	55 (2.17)	78 (3.07)

The models with a motor model number to which "A" is suffixed are not equipped with a capacitor cap.

Gear head (dimensions)

Scale: 1/4, Unit: mm (inch)

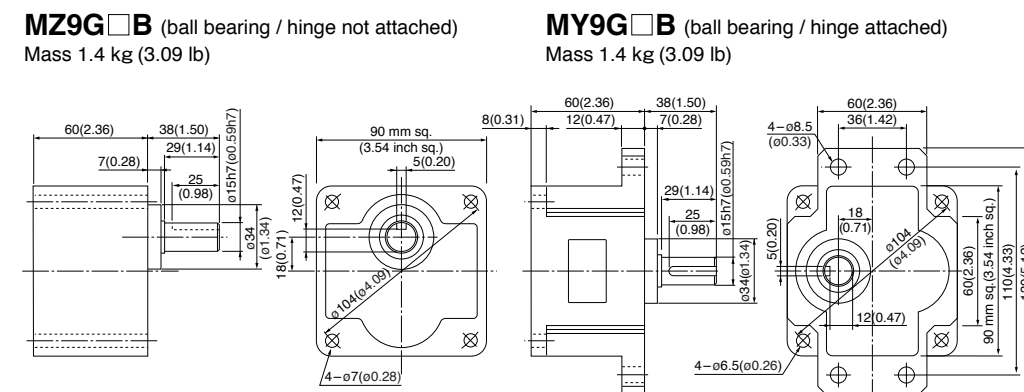

Key and keyway (dimensions) [attachment]

MZ9G□B
MY9G□B

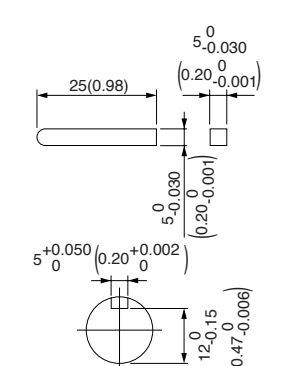

Note) MZ / MY is available for a gear head of either type.

(Note) Because the dimensions may be subject to change, also check the determinate dimensions if the gear head is to be used for design.

Electromagnetic brake single-phase motor (leadwire)

90 mm (3.54 inch) sq. 90 W

Specifications

Size	Motor model No.	Number of pole (P)	Output (W)	Voltage (V)	Frequency (Hz)	Rating (min)	Rating				Starting current (A)	Starting torque N·m (oz·in)	Brake Input (W)	Brake Current (A)	Brake Friction Torque N·m (oz·in)	Capacitor (μF) (rated voltage)
							Input (W)	Current (A)	Speed (r/min)	Torque N·m (oz·in)						
90 mm sq.	M9RZ90GB4L	4	90	100	50	30	171	1.7	1225	0.70 (99.1)	2.8	0.68 (96.3)	9	0.10	0.39 (55.2)	30 (200 V)
							181	1.9	1525	0.56 (79.3)	2.7	0.70 (99.1)	9	0.10	0.39 (55.2)	
	M9RZ90GB4Y	4	90	200	50	30	171	0.93	1225	0.70 (99.1)	1.4	0.68 (96.3)	9	0.05	0.39 (55.2)	7.5 (370 V)
							181	0.96	1525	0.56 (79.3)	1.4	0.70 (99.1)	9	0.05	0.39 (55.2)	

* The specifications and wire connections of the round shaft motor are the same as those of the pinion shaft type. For the dimensional outline drawing, refer to page B-220.

Permissible torque at output shaft of gear head

* The speed shown below is a calculated value based on the synchronous rotational speed. Depending on the load, the speed is less than the indicated value by 2% to 20%.

Unit of permissible torque: upper (N·m) / lower (lb·in)

Reduction ratio	Unit of permissible torque: upper (N·m) / lower (lb·in)																									
	3	3.6	5	6	7.5	9	10	12.5	15	18	20	25	30	36	50	60	75	90	100	120	150	180	200			
Speed (r/min)	50 Hz	500	416.7	300	250	200	166.7	150	120	100	83.3	75	60	50	41.7	30	25	20	16.7	15	12.5	10	8.3	7.5		
Applicable gear head	60 Hz	600	500	360	300	240	200	180	144	120	100	90	72	60	50	36	30	24	20	18	15	12	10	9		
	MZ9G3B to MZ9G200B (ball bearing / hinge not attached)	50 Hz	1.37 (12.1)	1.67 (14.8)	2.25 (19.9)	2.74 (24.3)	3.43 (30.4)	4.12 (36.5)	4.51 (39.9)	5.68 (50.3)	6.76 (59.8)	8.04 (71.2)	9.02 (79.8)	10.9 (96.5)	13.0 (115)	15.7 (139)	19.6 (173)									
60 Hz		1.18 (10.4)	1.37 (12.1)	1.86 (16.5)	2.25 (19.9)	2.84 (25.1)	3.43 (30.4)	3.72 (32.9)	4.70 (41.6)	5.68 (50.3)	6.76 (59.8)	7.55 (66.8)	9.21 (81.5)	10.9 (96.5)	13.0 (115)	18.3 (162)										
MY9G3B to MY9G200B (ball bearing / hinge attached)	50 Hz	1.37 (12.1)	1.67 (14.8)	2.25 (19.9)	2.74 (24.3)	3.43 (30.4)	4.12 (36.5)	4.51 (39.9)	5.68 (50.3)	6.76 (59.8)	8.04 (71.2)	9.02 (79.8)	10.9 (96.5)	13.0 (115)	15.7 (139)	19.6 (173)										
	60 Hz	1.18 (10.4)	1.37 (12.1)	1.86 (16.5)	2.25 (19.9)	2.84 (25.1)	3.43 (30.4)	3.72 (32.9)	4.70 (41.6)	5.68 (50.3)	6.76 (59.8)	7.55 (66.8)	9.21 (81.5)	10.9 (96.5)	13.0 (115)	18.3 (162)										
Rotational direction	Same as motor rotational direction										Reverse to motor rotational direction															

Permissible torque at output shaft of gear head using decimal gear head

Applicable gear head		Reduction ratio	Reduction ratio												
Bearing	Decimal gear head		Speed (r/min)	50 Hz	6	5	4.2	3	2.5	2	1.7	1.5	1.3	1	0.8
MZ9G□B (ball bearing / hinge not attached)	MZ9G10XB	Permissible torque	N·m (lb·in)	19.6 (173)	19.6 (173)	19.6 (173)	19.6 (173)	19.6 (173)	19.6 (173)	19.6 (173)	19.6 (173)	19.6 (173)	19.6 (173)	19.6 (173)	19.6 (173)
				Rotational direction	Reverse to motor rotational direction	Same as motor rotational direction									

Connection diagram

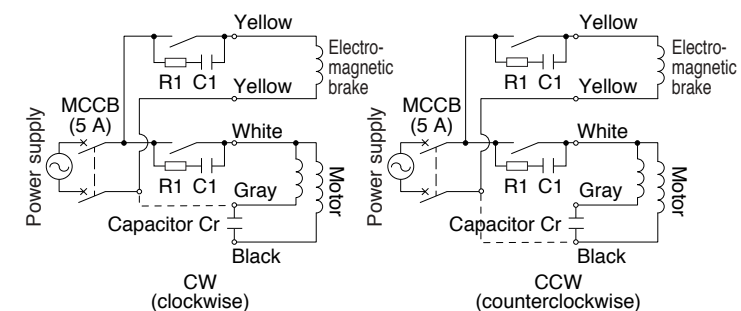

<Note>
 1. Brake will be activated and held when electromagnetic brake power is turned OFF.
 2. Protect the contacts by inserting the spark-killer circuit (R1+C1) between the contacts. R1+C1 is provided as an option (DV0P008A, refer to page D-3).
 3. Use a circuit breaker for the power supply.

Speed-torque characteristics

M9RZ90GB4L

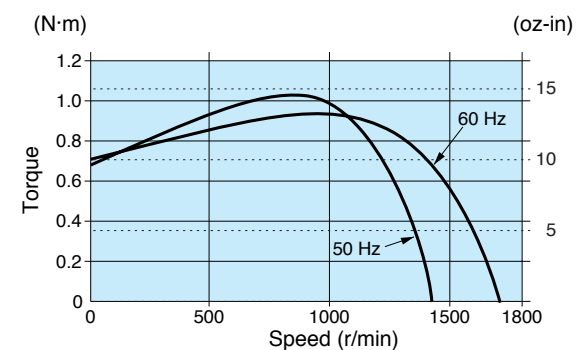

Motor (dimensions)

Scale: 1/4, Unit: mm (inch)

M9RZ90GB4L 4P 90 W 100 V (with fan)
 M9RZ90GB4Y 4P 90 W 200 V (with fan)

Mass 3.8 kg (8.38 lb)
 Helical gear
 Module 0.6
 Number of teeth 9

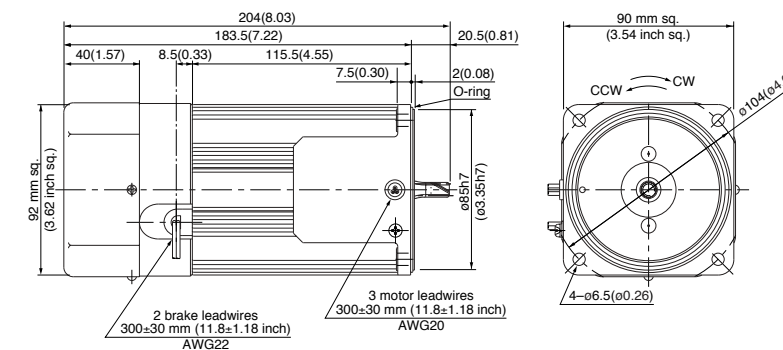

Capacitor (dimensions) [attachment]

Unit: mm (inch)

Capacitor cap (dimensions) [option]

Unit: mm (inch)

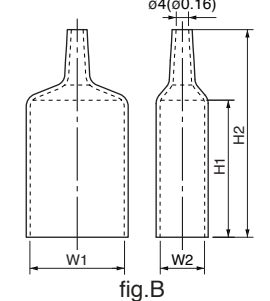
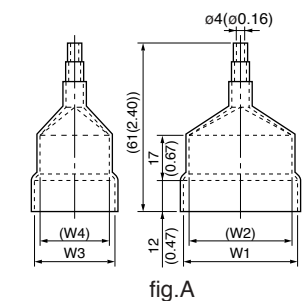
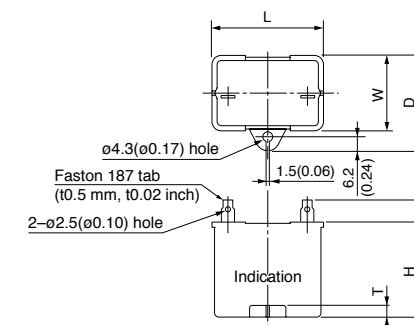

Capacitor dimension list Unit: upper (mm) / lower (inch)

Model number of motor	Model number of capacitor (attachment)	L	W	D	H	T	Capacitor cap (option)	W1	W2	W3	W4	H1	H2	fig.
M9RZ90GB4L	M0PC30M20	50.2 (1.98)	31 (1.22)	41 (1.61)	42 (1.65)	5 (0.20)	M0PC5032	50 (1.97)	48 (1.89)	32.5 (1.28)	29.5 (1.16)	—	—	A
M9RZ90GB4Y	M0PC7.5M37	50 (1.97)	34 (1.34)	45 (1.77)	45 (1.77)	6 (0.24)	M0PC5835G	58 (2.28)	35 (1.38)	—	—	55 (2.17)	78 (3.07)	B

Gear head (dimensions)

Scale: 1/4, Unit: mm (inch)

MZ9G□B (ball bearing / hinge not attached)
 Mass 1.4 kg (3.09 lb)

MY9G□B (ball bearing / hinge attached)
 Mass 1.4 kg (3.09 lb)

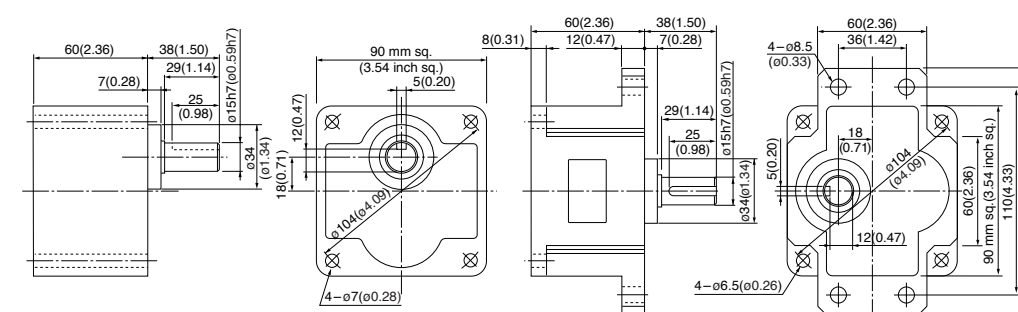

Key and keyway (dimensions) [attachment]

MZ9G□B
 MY9G□B

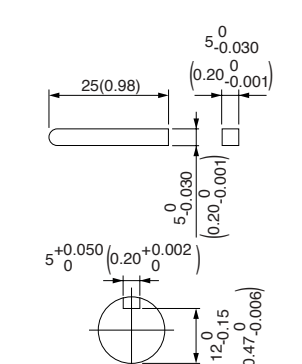

Note) MZ / MY is available for a gear head of either type.

(Note) Because the dimensions may be subject to change, also check the determinate dimensions if the gear head is to be used for design.

Electromagnetic brake single-phase motor (leadwire)

US CE CCC 90 mm (3.54 inch) sq. 90 W

Specifications

Size	Motor model No.	Number of pole (P)	Output (W)	Voltage (V)	Frequency (Hz)	Rating (min)	Rating				Starting current (A)	Starting torque N·m (oz-in)	Brake Input (W)	Brake Current (A)	Brake Friction Torque N·m (oz-in)	Capacitor (μF) (rated voltage)
							Input (W)	Current (A)	Speed (r/min)	Torque N·m (oz-in)						
90 mm sq.	M9RZ90GB4LG M9RZ90GB4LGA	4	90	100	50	30	175	1.8	1250	0.69 (97.7)	3.0	0.72 (102)	9	0.10	0.39 (55.2)	32
							188	1.9	1575	0.55 (77.9)	3.0	0.72 (102)	9	0.10	0.39 (55.2)	(250 V)
	M9RZ90GB4DG M9RZ90GB4DGA	4	90	110	60	30	181	1.7	1600	0.54 (76.5)	3.1	0.76 (108)	11	0.11	0.39 (55.2)	28
							190	1.7	1625	0.53 (75.1)	3.2	0.83 (118)	12	0.12	0.39 (55.2)	(250 V)
	M9RZ90GB4YG M9RZ90GB4YGA	4	90	200	50	30	171	0.86	1225	0.70 (99.1)	1.4	0.72 (102)	9	0.05	0.39 (55.2)	8
							193	1.0	1550	0.55 (77.9)	1.4	0.72 (102)	9	0.05	0.39 (55.2)	(450 V)
	M9RZ90GB4GG M9RZ90GB4GGA	4	90	220	60	30	179	0.84	1275	0.67 (94.9)	1.5	0.76 (108)	11	0.06	0.39 (55.2)	7
							184	0.84	1600	0.54 (76.5)	1.5	0.76 (108)	11	0.06	0.39 (55.2)	(450 V)
	M9RZ90GB4GG M9RZ90GB4GGA	4	90	230	50	30	192	0.89	1275	0.67 (94.9)	1.6	0.83 (118)	12	0.06	0.39 (55.2)	7
							192	0.84	1600	0.54 (76.5)	1.5	0.83 (118)	12	0.06	0.39 (55.2)	(450 V)

The specifications and wire connections of the round shaft motor are the same as those of the pinion shaft type. For the dimensional outline drawing, refer to page B-220.

The models with a motor model number to which "A" is suffixed are not equipped with a capacitor cap. The models with a motor model number to which "A" is suffixed are not sold or available in Japan.

Permissible torque at output shaft of gear head

The speed shown below is a calculated value based on the synchronous rotational speed. Depending on the load, the speed is less than the indicated value by 2% to 20%.

Unit of permissible torque: upper (N·m) / lower (lb-in)

Reduction ratio	Speed (r/min)																						
	3	3.6	5	6	7.5	9	10	12.5	15	18	20	25	30	36	50	60	75	90	100	120	150	180	200
50 Hz	500	416.7	300	250	200	166.7	150	120	100	83.3	75	60	50	41.7	30	25	20	16.7	15	12.5	10	8.3	7.5
60 Hz	600	500	360	300	240	200	180	144	120	100	90	72	60	50	36	30	24	20	18	15	12	10	9
Applicable gear head	Same as motor rotational direction												Reverse to motor rotational direction										
	Same as motor rotational direction												Same as motor rotational direction										

Permissible torque at output shaft of gear head using decimal gear head

Applicable gear head	Reduction ratio	Speed (r/min)															
		250	300	360	500	600	750	900	1000	1200	1500	1800					
Bearing	Decimal gear head	50 Hz	6	5	4.2	3	2.5	2	1.7	1.5	1.3	1	0.8				
		60 Hz	7.2	6	5	3.6	3	2.4	2	1.8	1.5	1.2	1				
MZ9G□B (ball bearing / hinge not attached) MY9G□B (ball bearing / hinge attached)	MZ9G10XB	Permissible torque	N·m (lb-in)	19.6 (173)	19.6 (173)	19.6 (173)	19.6 (173)	19.6 (173)	19.6 (173)	19.6 (173)	19.6 (173)	19.6 (173)	19.6 (173)				
		Rotational direction	Reverse to motor rotational direction	Same as motor rotational direction													

Connection diagram

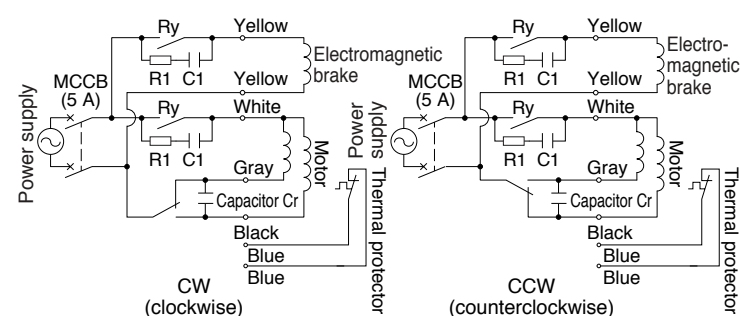

- <Note>
- Brake will be activated and held when electromagnetic brake power is turned OFF.
 - Protect the contacts by inserting the spark-killer circuit (R1+C1) between the contacts. R1+C1 is provided as an option (DV0P008A, refer to page D-3).
 - Refer to page A-58 for connection of thermal protector.
 - Use a circuit breaker for the power supply.

Speed-torque characteristics

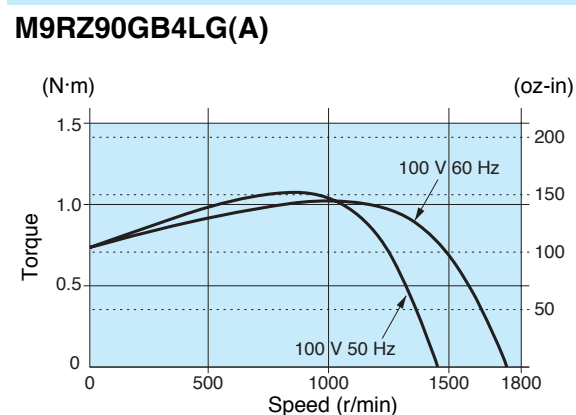

Motor (dimensions)

Scale: 1/4, Unit: mm (inch)

M9RZ90GB4LG(A)	4P 90 W 100 V (with fan)
M9RZ90GB4DG(A)	4P 90 W 110 V / 115 V (with fan)
M9RZ90GB4YG(A)	4P 90 W 200 V (with fan)
M9RZ90GB4GG(A)	4P 90 W 220 V / 230 V (with fan)

Mass	Helical gear	Module	Number of teeth
3.8 kg (8.38 lb)	0.6	9	

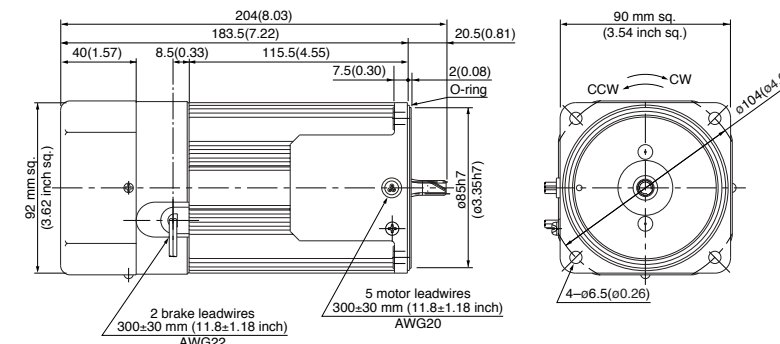

Capacitor (dimensions) [attachment]

Unit: mm (inch)

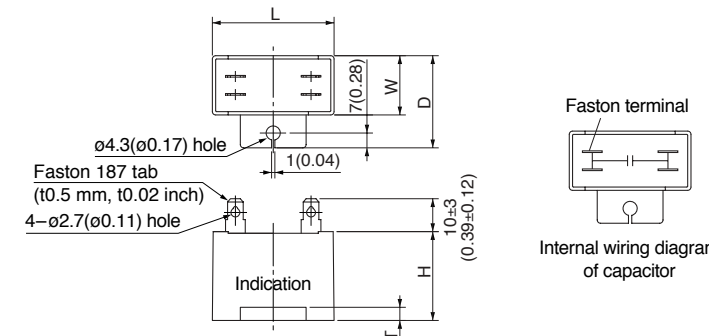

Capacitor cap (dimensions) [attachment]

Unit: mm (inch)

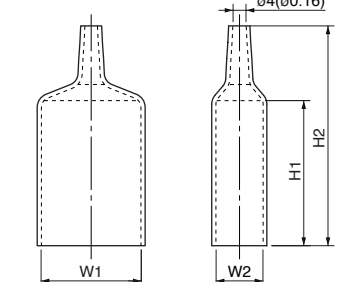

Capacitor dimension list

Unit: upper (mm) / lower (inch)

Model number of motor	Model number of capacitor (attachment)	L	W	D	H	T	Capacitor cap (attachment)	W1	W2	H1	H2
M9RZ90GB4LG(A)	M0PC32M25G	58 (2.28)	35 (1.38)	50 (1.97)	50 (1.97)	4 (0.16)	M0PC5835G	58 (2.28)	35 (1.38)	55 (2.17)	78 (3.07)
M9RZ90GB4DG(A)	M0PC28M25G	58 (2.28)	35 (1.38)	50 (1.97)	50 (1.97)	4 (0.16)	M0PC5835G	58 (2.28)	35 (1.38)	55 (2.17)	78 (3.07)
M9RZ90GB4YG(A)	M0PC8M45G	58 (2.28)	35 (1.38)	50 (1.97)	50 (1.97)	4 (0.16)	M0PC5835G	58 (2.28)	35 (1.38)	55 (2.17)	78 (3.07)
M9RZ90GB4GG(A)	M0PC7M45G	58 (2.28)	35 (1.38)	50 (1.97)	50 (1.97)	4 (0.16)	M0PC5835G	58 (2.28)	35 (1.38)	55 (2.17)	78 (3.07)

The models with a motor model number to which "A" is suffixed are not equipped with a capacitor cap.

Gear head (dimensions)

Scale: 1/4, Unit: mm (inch)

MZ9G□B (ball bearing / hinge not attached)
Mass 1.4 kg (3.09 lb)

MY9G□B (ball bearing / hinge attached)
Mass 1.4 kg (3.09 lb)

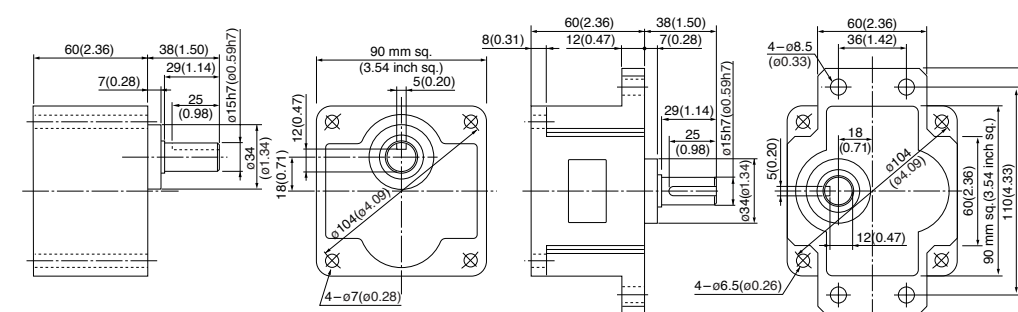

Key and keyway (dimensions) [attachment]

MZ9G□B
MY9G□B

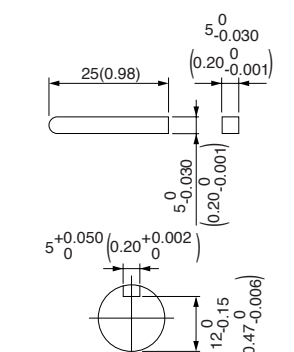

Note) MZ / MY is available for a gear head of either type.

(Note) Because the dimensions may be subject to change, also check the determinate dimensions if the gear head is to be used for design.

Electromagnetic brake 3-phase motor (leadwire)

80 mm (3.15 inch) sq. 25 W

Specifications

Size	Motor model No.	Number of pole (P)	Output (W)	Voltage (V)	Frequency (Hz)	Rating (min)	Rating				Starting current (A)	Starting torque N·m (oz-in)	Brake Input (W)	Brake Current (A)	Brake Friction Torque N·m (oz-in)
							Input (W)	Current (A)	Speed (r/min)	Torque N·m (oz-in)					
80 mm sq.	M8MX25GB4Y	4	25	200	50	Cont.	50	0.25	1350	0.18 (25.5)	0.62	0.54 (76.5)	6	0.03	0.10 (14.2)
					60	Cont.	47	0.22	1625	0.15 (21.2)	0.58	0.40 (56.6)	6	0.03	0.10 (14.2)
		4	25	220	50	Cont.	54	0.27	1375	0.18 (25.5)	0.67	0.66 (93.5)	7	0.04	0.10 (14.2)
					60	Cont.	49	0.23	1650	0.15 (21.2)	0.64	0.50 (70.8)	7	0.04	0.10 (14.2)

* The specifications and wire connections of the round shaft motor are the same as those of the pinion shaft type. For the dimensional outline drawing, refer to page B-221.

Permissible torque at output shaft of gear head

* The speed shown below is a calculated value based on the synchronous rotational speed. Depending on the load, the speed is less than the indicated value by 2 % to 20 %.

Unit of permissible torque: upper (N·m) / lower (lb-in)

Reduction ratio	Speed (r/min)																							
	50 Hz	60 Hz	3	3.6	5	6	7.5	9	10	12.5	15	18	20	25	30	36	50	60	75	90	100	120	150	180
MX8G3B to MX8G180B (ball bearing)	0.39 (3.45)	0.47 (4.16)	0.66 (5.84)	0.78 (6.90)	0.98 (8.67)	1.18 (10.4)	1.27 (11.2)	1.57 (13.9)	1.96 (17.3)	2.35 (20.8)	2.55 (22.6)	3.14 (27.8)	3.82 (33.8)	4.61 (40.8)	6.37 (56.4)	7.64 (67.6)								7.84 (69.4)
MX8G3M to MX8G180M (metal bearing)	0.32 (2.83)	0.39 (3.45)	0.55 (4.87)	0.66 (5.84)	0.81 (7.17)	0.98 (8.67)	1.08 (9.56)	1.27 (11.2)	1.57 (13.9)	1.96 (17.3)	2.06 (18.2)	2.65 (23.5)	3.14 (27.8)	3.82 (33.8)	5.29 (46.8)	6.37 (56.4)								7.84 (69.4)

Rotational direction: Same as motor rotational direction / Reverse to motor rotational direction

Permissible torque at output shaft of gear head using decimal gear head

Applicable gear head		Reduction ratio	Speed (r/min)													
Bearing	Decimal gear head		50 Hz	60 Hz	7.5	6	5	4.2	3	2.5	2	1.7	1.5	1.3	1	0.8
MX8G□B (ball bearing) MX8G□M (metal bearing)	MX8G10XB	Permissible torque	N·m (lb-in)	7.84 (69.4)	7.84 (69.4)	7.84 (69.4)	7.84 (69.4)	7.84 (69.4)	7.84 (69.4)	7.84 (69.4)	7.84 (69.4)	7.84 (69.4)	7.84 (69.4)	7.84 (69.4)	7.84 (69.4)	7.84 (69.4)
		Rotational direction		Same as motor rotational direction	Reverse to motor rotational direction											

Connection diagram

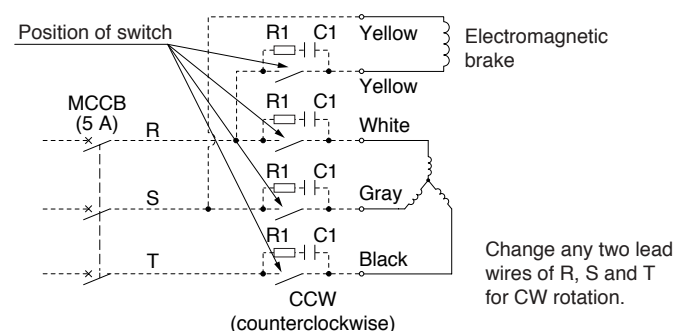

- <Note>
- Brake will be activated and held when electromagnetic brake power is turned OFF.
 - Protect the contacts by inserting the spark-killer circuit (R1+C1) between the contacts. R1+C1 is provided as an option (DV0P008A, refer to page D-3).
 - Use a circuit breaker for the power supply.

Speed-torque characteristics

M8MX25GB4Y

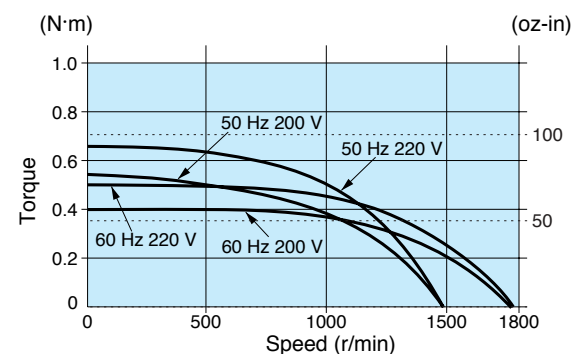

Motor (dimensions)

M8MX25GB4Y 4P 25 W 200 V / 220 V

Scale: 1/3, Unit: mm (inch)

Mass 2.1 kg (4.63 lb)
Helical gear
Module 0.5
Number of teeth 9

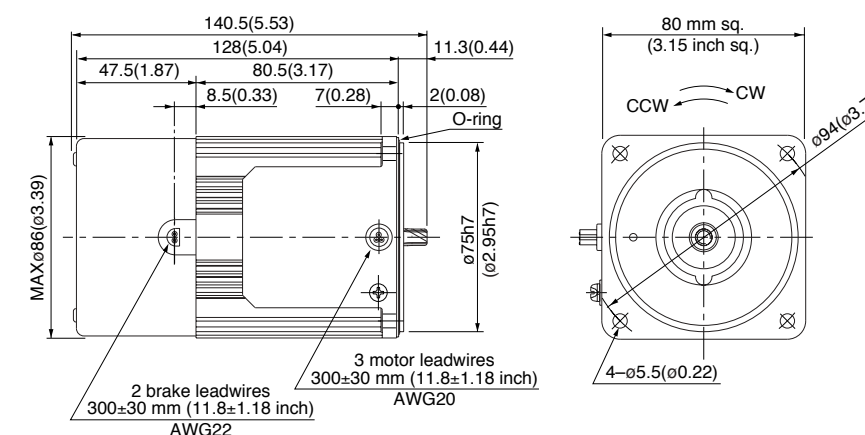

Gear head (dimensions)

Scale: 1/3, Unit: mm (inch)

MX8G□B (ball bearing) Mass 0.6 kg (1.32 lb) MX8G□M (metal bearing) Mass 0.6 kg (1.32 lb)

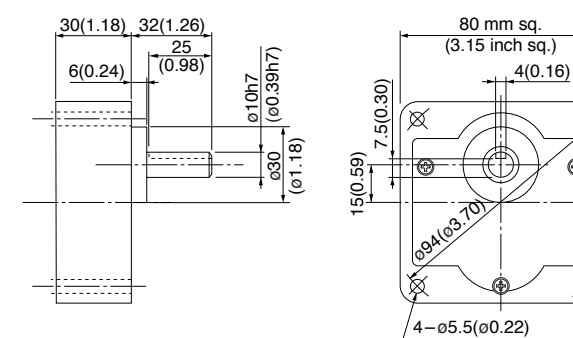

Key and keyway (dimensions) [attachment]

MX8G□B(M)

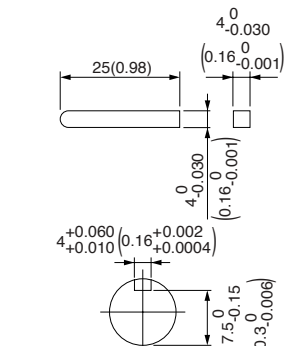

* Please read your User's manual carefully so that you will understand the operation and safety precautions before attempting to operate the system.

(Note) Because the dimensions may be subject to change, also check the determinate dimensions if the gear head is to be used for design.

Electromagnetic brake 3-phase motor (leadwire)

US CE 80 mm (3.15 inch) sq. 25 W

Specifications

Size	Motor model No.	Number of pole (P)	Output (W)	Voltage (V)	Frequency (Hz)	Rating (min)	Rating				Starting current (A)	Starting torque N·m (oz-in)	Brake Input (W)	Brake Current (A)	Brake Friction Torque N·m (oz-in)
							Input (W)	Current (A)	Speed (r/min)	Torque N·m (oz-in)					
80 mm Sq.	M8MX25GB4YG M8MX25GB4YGA	4	25	200	50	Cont.	50	0.25	1350	0.18 (25.5)	0.62	0.54 (76.5)	6	0.03	0.10 (14.2)
							47	0.22	1625	0.15 (21.2)	0.58	0.40 (56.6)	6	0.03	0.10 (14.2)
							49	0.23	1650	0.14 (19.8)	0.64	0.50 (70.8)	7	0.04	0.10 (14.2)
							50	0.24	1675	0.14 (19.8)	0.65	0.54 (76.5)	8	0.04	0.10 (14.2)

The specifications and wire connections of the round shaft motor are the same as those of the pinion shaft type. For the dimensional outline drawing, refer to page B-221.
The models with a motor model number to which "A" is suffixed are not sold or available in Japan.

Permissible torque at output shaft of gear head

The speed shown below is a calculated value based on the synchronous rotational speed. Depending on the load, the speed is less than the indicated value by 2% to 20%.

Unit of permissible torque: upper (N·m) / lower (lb-in)

Reduction ratio	Unit of permissible torque: upper (N·m) / lower (lb-in)																							
	3	3.6	5	6	7.5	9	10	12.5	15	18	20	25	30	36	50	60	75	90	100	120	150	180		
Speed (r/min)	50 Hz		500	416.7	300	250	200	166.7	150	120	100	83.3	75	60	50	41.7	30	25	20	16.7	15	12.5	10	8.3
	60 Hz		600	500	360	300	240	200	180	144	120	100	90	72	60	50	36	30	24	20	18	15	12	10
Applicable gear head	MX8G3B to MX8G180B (ball bearing)		50 Hz		0.39 (3.45)	0.47 (4.16)	0.66 (5.84)	0.78 (6.90)	0.98 (8.67)	1.18 (10.4)	1.27 (11.2)	1.57 (13.9)	1.96 (17.3)	2.35 (20.8)	2.55 (22.6)	3.14 (27.8)	3.82 (33.8)	4.61 (40.8)	6.37 (56.4)	7.64 (67.6)	7.84 (69.4)			
	MX8G3M to MX8G180M (metal bearing)		60 Hz		0.32 (2.83)	0.39 (3.45)	0.55 (4.87)	0.66 (5.84)	0.81 (7.17)	0.98 (8.67)	1.08 (9.56)	1.27 (11.2)	1.57 (13.9)	1.96 (17.3)	2.06 (18.2)	2.65 (23.5)	3.14 (27.8)	3.82 (33.8)	5.29 (46.8)	6.37 (56.4)	7.84 (69.4)			
Rotational direction	Same as motor rotational direction												Reverse to motor rotational direction											

Permissible torque at output shaft of gear head using decimal gear head

Applicable gear head		Reduction ratio	Reduction ratio														
Bearing	Decimal gear head		Speed (r/min)	200	250	300	360	500	600	750	900	1000	1200	1500	1800		
		MX8G□B (ball bearing) MX8G□M (metal bearing)		MX8G10XB	50 Hz	7.5	6	5	4.2	3	2.5	2	1.7	1.5	1.3	1	0.8
60 Hz	9		7.2		6	5	3.6	3	2.4	2	1.8	1.5	1.2	1			
		Permissible torque	N·m	7.84 (69.4)	7.84 (69.4)	7.84 (69.4)	7.84 (69.4)	7.84 (69.4)	7.84 (69.4)	7.84 (69.4)	7.84 (69.4)	7.84 (69.4)	7.84 (69.4)	7.84 (69.4)			
		Rotational direction	Same as motor rotational direction			Reverse to motor rotational direction											

Connection diagram

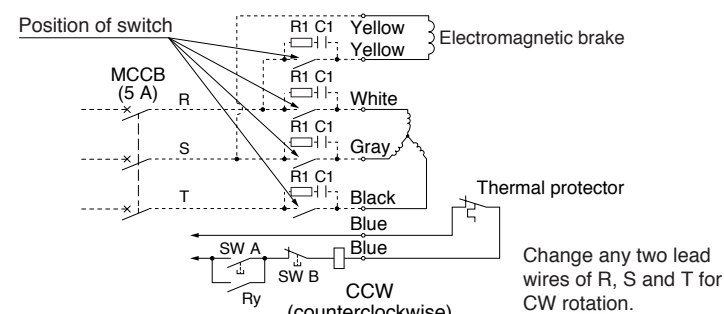

<Note>
1. Brake will be activated and held when electromagnetic brake power is turned OFF.
2. Protect the contacts by inserting the spark-killer circuit (R1+C1) between the contacts. R1+C1 is provided as an option (DV0P008A, refer to page D-3).
3. Refer to page A-58 for connection of thermal protector.
4. Use a circuit breaker for the power supply.

Speed-torque characteristics

M8MX25GB4YG(A)

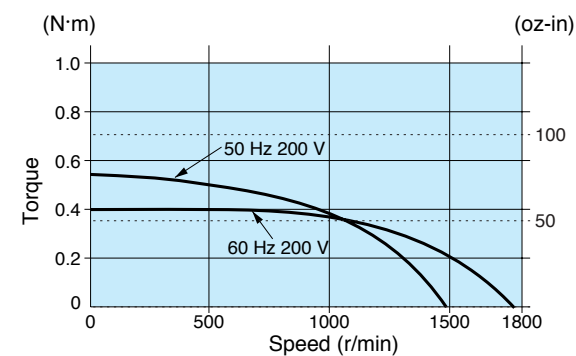

Motor (dimensions)

M8MX25GB4YG(A) 4P 25 W 200 V / 220 V / 230 V

Scale: 1/3, Unit: mm (inch)

Mass 2.1 kg 4.63 lb
Helical gear
Module 0.5
Number of teeth 9

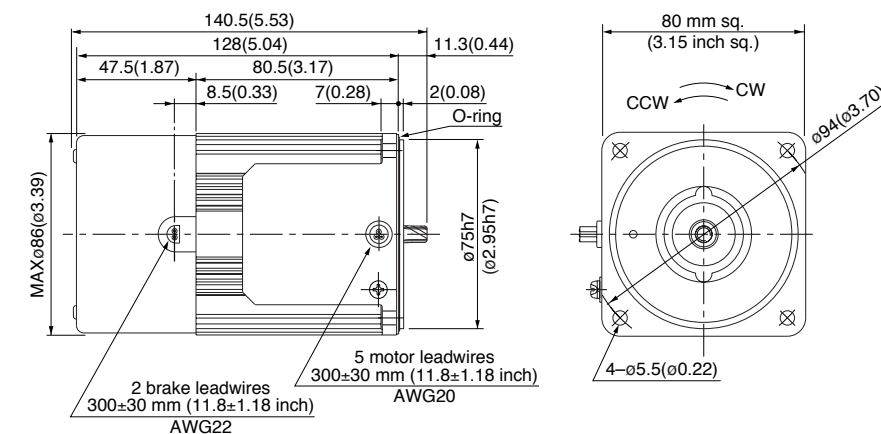

Gear head (dimensions)

Scale: 1/3, Unit: mm (inch)

MX8G□B (ball bearing) Mass 0.6 kg (1.32 lb) MX8G□M (metal bearing) Mass 0.6 kg (1.32 lb)

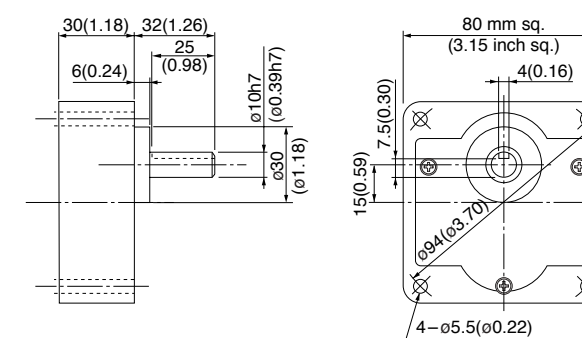

Key and keyway (dimensions) [attachment]

MX8G□B(M)

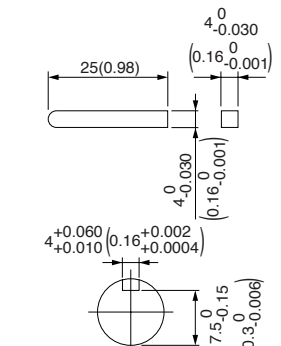

Please read your User's manual carefully so that you will understand the operation and safety precautions before attempting to operate the system.

(Note) Because the dimensions may be subject to change, also check the determinate dimensions if the gear head is to be used for design.

Induction motor
Reversible motor
3-phase motor
Electromagnetic brake motor
Variable speed induction motor
Variable speed reversible motor
Variable speed electromagnetic brake single-phase motor
Variable speed unit motor
C&B motor
2-pole round shaft motor
Gear head
Gear head -inch (U.S.A.)

Electromagnetic brake 3-phase motor (leadwire)

90 mm (3.54 inch) sq. 40 W

Specifications

Size	Motor model No.	Number of pole (P)	Output (W)	Voltage (V)	Frequency (Hz)	Rating (min)	Rating				Starting current (A)	Starting torque N·m (oz-in)	Brake Input (W)	Brake Current (A)	Brake Friction Torque N·m (oz-in)
							Input (W)	Current (A)	Speed (r/min)	Torque N·m (oz-in)					
90 mm sq.	M9MX40GB4Y	4	40	200	50	Cont.	69	0.31	1350	0.28 (39.7)	0.90	0.72 (102)	9	0.05	0.20 (28.3)
					60	Cont.	68	0.29	1625	0.24 (34.0)	0.82	0.51 (72.2)	9	0.05	0.20 (28.3)
		4	40	220	50	Cont.	70	0.32	1375	0.27 (38.2)	1.00	0.88 (125)	11	0.06	0.20 (28.3)
					60	Cont.	66	0.28	1675	0.23 (32.6)	0.91	0.63 (89.2)	11	0.06	0.20 (28.3)

* The specifications and wire connections of the round shaft motor are the same as those of the pinion shaft type. For the dimensional outline drawing, refer to page B-221.

Permissible torque at output shaft of gear head

* The speed shown below is a calculated value based on the synchronous rotational speed. Depending on the load, the speed is less than the indicated value by 2 % to 20 %.

Unit of permissible torque: upper (N·m) / lower (lb-in)

Reduction ratio	Unit of permissible torque: upper (N·m) / lower (lb-in)																						
	3	3.6	5	6	7.5	9	10	12.5	15	18	20	25	30	36	50	60	75	90	100	120	150	180	
Speed (r/min)	50 Hz	500	416.7	300	250	200	166.7	150	120	100	83.3	75	60	50	41.7	30	25	20	16.7	15	12.5	10	8.3
	60 Hz	600	500	360	300	240	200	180	144	120	100	90	72	60	50	36	30	24	20	18	15	12	10
Applicable gear head	MX9G3B to MX9G180B (ball bearing)	50 Hz	0.66 (5.84)	0.78 (6.90)	1.08 (9.56)	1.27 (11.2)	1.57 (13.9)	1.86 (16.5)	2.25 (19.9)	2.74 (24.3)	3.23 (28.6)	3.92 (34.7)	4.41 (39.0)	5.29 (46.8)	6.37 (56.4)	7.94 (70.3)	9.80 (86.7)						
		60 Hz	0.55 (4.87)	0.66 (5.84)	0.90 (7.97)	1.08 (9.56)	1.27 (11.2)	1.57 (13.9)	1.76 (15.6)	2.25 (19.9)	2.74 (24.3)	3.23 (28.6)	3.53 (31.2)	4.41 (39.0)	5.29 (46.8)	6.37 (56.4)	8.82 (78.1)	9.80 (86.7)					
Rotational direction		Same as motor rotational direction											Reverse to motor rotational direction										

Permissible torque at output shaft of gear head using decimal gear head

Applicable gear head		Reduction ratio	Reduction ratio													
Bearing	Decimal gear head		Speed (r/min)	200	250	300	360	500	600	750	900	1000	1200	1500	1800	
		MX9G□B (ball bearing)		MX9G10XB	50 Hz	9.80 (86.7)	9.80 (86.7)	9.80 (86.7)	9.80 (86.7)	9.80 (86.7)	9.80 (86.7)	9.80 (86.7)	9.80 (86.7)	9.80 (86.7)	9.80 (86.7)	9.80 (86.7)
60 Hz	9.80 (86.7)		9.80 (86.7)		9.80 (86.7)	9.80 (86.7)	9.80 (86.7)	9.80 (86.7)	9.80 (86.7)	9.80 (86.7)	9.80 (86.7)	9.80 (86.7)	9.80 (86.7)	9.80 (86.7)	9.80 (86.7)	
Rotational direction		Same as motor rotational direction			Reverse to motor rotational direction											

Connection diagram

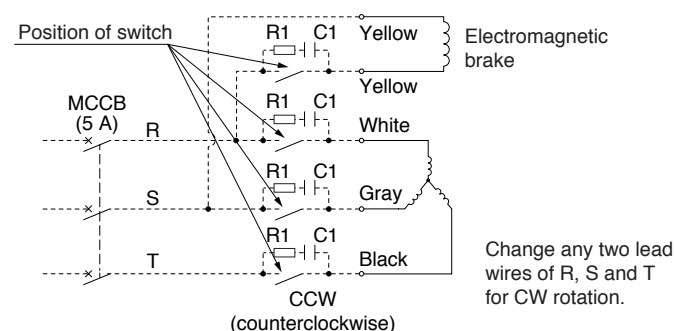

- <Note>
- Brake will be activated and held when electromagnetic brake power is turned OFF.
 - Protect the contacts by inserting the spark-killer circuit (R1+C1) between the contacts. R1+C1 is provided as an option (DV0P008A, refer to page D-3).
 - Use a circuit breaker for the power supply.

Speed-torque characteristics

M9MX40GB4Y

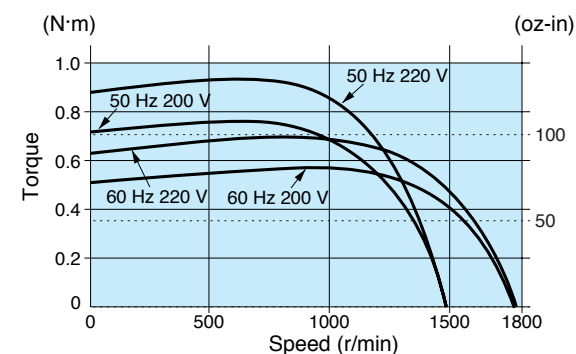

Motor (dimensions)

M9MX40GB4Y 4P 40 W 200 V / 220 V

Scale: 1/3, Unit: mm (inch)

Mass 3.2 kg (7.05 lb)
Helical gear
Module 0.55
Number of teeth 9

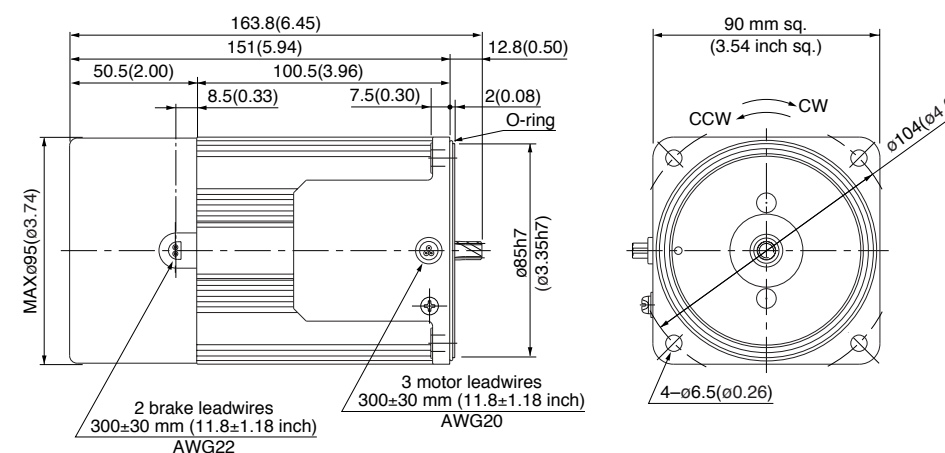

Gear head (dimensions)

Scale: 1/3, Unit: mm (inch)

MX9G□B (ball bearing) Mass 0.8 kg (1.76 lb) MX9G□M (metal bearing) Mass 0.8 kg (1.76 lb)

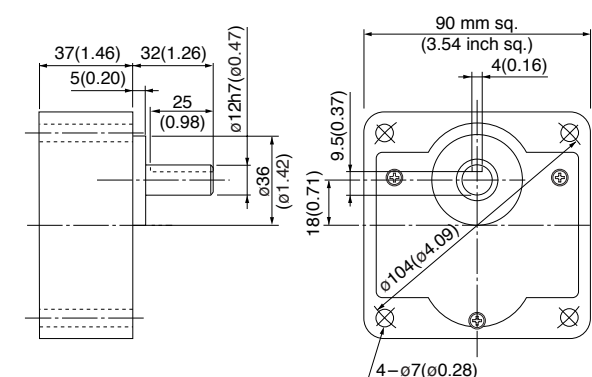

Key and keyway (dimensions) [attachment]

MX9G□B(M)

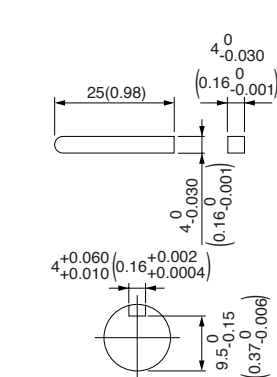

* Please read your User's manual carefully so that you will understand the operation and safety precautions before attempting to operate the system.

(Note) Because the dimensions may be subject to change, also check the determinate dimensions if the gear head is to be used for design.

Electromagnetic brake 3-phase motor (leadwire)

US CE CCC 90 mm (3.54 inch) sq. 40 W

Specifications

Size	Motor model No.	Number of pole (P)	Output (W)	Voltage (V)	Frequency (Hz)	Rating (min)	Rating				Starting current (A)	Starting torque N·m (oz-in)	Brake Input (W)	Brake Current (A)	Brake Friction Torque N·m (oz-in)
							Input (W)	Current (A)	Speed (r/min)	Torque N·m (oz-in)					
90 mm sq.	M9MX40GB4YG M9MX40GB4YGA	4	40	200	50	Cont.	69	0.31	1350	0.28 (39.7)	0.90	0.72 (102)	9	0.05	0.20 (28.3)
					60	Cont.	68	0.29	1625	0.24 (34.0)	0.82	0.51 (72.2)	9	0.05	0.20 (28.3)
				220	60	Cont.	66	0.28	1675	0.23 (32.6)	0.91	0.63 (89.2)	11	0.06	0.20 (28.3)
					60	Cont.	66	0.29	1675	0.23 (32.6)	0.96	0.69 (97.7)	11	0.06	0.20 (28.3)

The specifications and wire connections of the round shaft motor are the same as those of the pinion shaft type. For the dimensional outline drawing, refer to page B-221.
The models with a motor model number to which "A" is suffixed are not sold or available in Japan.

Permissible torque at output shaft of gear head

The speed shown below is a calculated value based on the synchronous rotational speed. Depending on the load, the speed is less than the indicated value by 2% to 20%.

Unit of permissible torque: upper (N·m) / lower (lb-in)

Reduction ratio	Unit of permissible torque: upper (N·m) / lower (lb-in)																						
	3	3.6	5	6	7.5	9	10	12.5	15	18	20	25	30	36	50	60	75	90	100	120	150	180	
Speed (r/min)	50 Hz	500	416.7	300	250	200	166.7	150	120	100	83.3	75	60	50	41.7	30	25	20	16.7	15	12.5	10	8.3
	60 Hz	600	500	360	300	240	200	180	144	120	100	90	72	60	50	36	30	24	20	18	15	12	10
Applicable gear head	MX9G3B to MX9G180B (ball bearing) MX9G3M to MX9G180M (metal bearing)	50 Hz	0.66 (5.84)	0.78 (6.90)	1.08 (9.56)	1.27 (11.2)	1.57 (13.9)	1.86 (16.5)	2.25 (19.9)	2.74 (24.3)	3.23 (28.6)	3.92 (34.7)	4.41 (39.0)	5.29 (46.8)	6.37 (56.4)	7.94 (70.3)	9.80 (86.7)						
		60 Hz	0.55 (4.87)	0.66 (5.84)	0.90 (7.97)	1.08 (9.56)	1.27 (11.2)	1.57 (13.9)	1.76 (15.6)	2.25 (19.9)	2.74 (24.3)	3.23 (28.6)	3.53 (31.2)	4.41 (39.0)	5.29 (46.8)	6.37 (56.4)	8.82 (78.1)	9.80 (86.7)					
Rotational direction		Same as motor rotational direction											Reverse to motor rotational direction										

Permissible torque at output shaft of gear head using decimal gear head

Applicable gear head		Reduction ratio	Reduction ratio													
Bearing	Decimal gear head		Speed (r/min)	200	250	300	360	500	600	750	900	1000	1200	1500	1800	
		MX9G□B (ball bearing) MX9G□M (metal bearing)		MX9G10XB	50 Hz	9.80 (86.7)	9.80 (86.7)	9.80 (86.7)	9.80 (86.7)	9.80 (86.7)	9.80 (86.7)	9.80 (86.7)	9.80 (86.7)	9.80 (86.7)	9.80 (86.7)	9.80 (86.7)
60 Hz	9.80 (86.7)		9.80 (86.7)		9.80 (86.7)	9.80 (86.7)	9.80 (86.7)	9.80 (86.7)	9.80 (86.7)	9.80 (86.7)	9.80 (86.7)	9.80 (86.7)	9.80 (86.7)	9.80 (86.7)	9.80 (86.7)	
Rotational direction		Same as motor rotational direction			Reverse to motor rotational direction											

Connection diagram

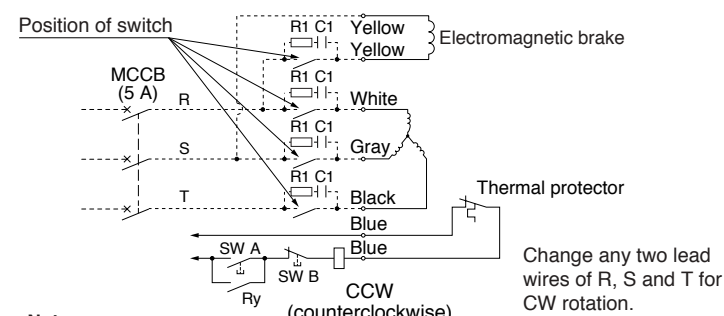

<Note>
1. Brake will be activated and held when electromagnetic brake power is turned OFF.
2. Protect the contacts by inserting the spark-killer circuit (R1+C1) between the contacts. R1+C1 is provided as an option (DV0P008A, refer to page D-3).
3. Refer to page A-58 for connection of thermal protector.
4. Use a circuit breaker for the power supply.

Speed-torque characteristics

M9MX40GB4YG(A)

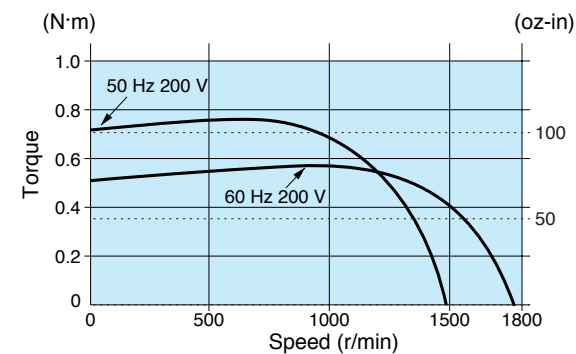

Motor (dimensions)

M9MX40GB4YG(A) 4P 40 W 200 V / 220 V / 230 V

Scale: 1/3, Unit: mm (inch)

Mass 3.2 kg (7.05 lb)
Helical gear
Module 0.55
Number of teeth 9

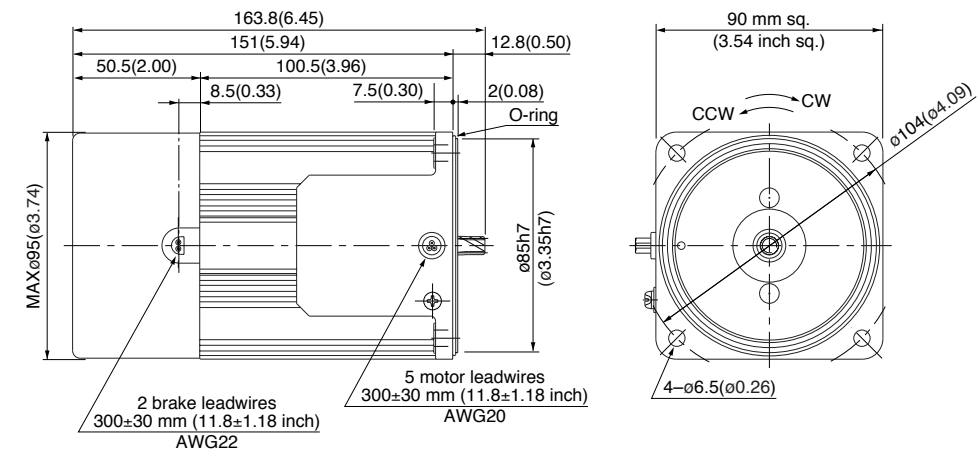

Gear head (dimensions)

Scale: 1/3, Unit: mm (inch)

MX9G□B (ball bearing) Mass 0.8 kg (1.76 lb) MX9G□M (metal bearing) Mass 0.8 kg (1.76 lb)

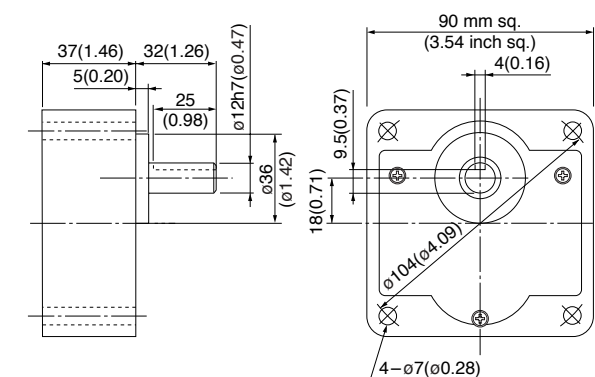

Key and keyway (dimensions) [attachment]

MX9G□B(M)

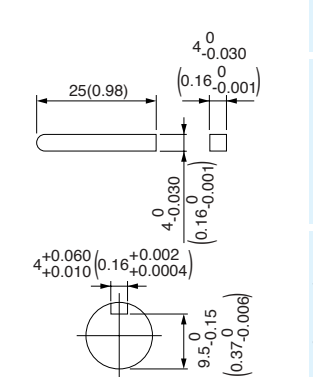

* Please read your User's manual carefully so that you will understand the operation and safety precautions before attempting to operate the system.

(Note) Because the dimensions may be subject to change, also check the determinate dimensions if the gear head is to be used for design.

Induction motor
Reversible motor
3-phase motor
Electromagnetic brake motor
Variable speed induction motor
Variable speed reversible motor
Variable speed electromagnetic brake single-phase motor
Variable speed unit motor
C&B motor
2-pole round shaft motor
Gear head
Gear head -inch (U.S.A.)

Electromagnetic brake 3-phase motor (leadwire)

90 mm (3.54 inch) sq. 60 W

Specifications

Size	Motor model No.	Number of pole (P)	Output (W)	Voltage (V)	Frequency (Hz)	Rating (min)	Rating				Starting current (A)	Starting torque N-m (oz-in)	Brake Input (W)	Brake Current (A)	Brake Friction Torque N-m (oz-in)
							Input (W)	Current (A)	Speed (r/min)	Torque N-m (oz-in)					
90 mm sq.	M9MZ60GB4Y	4	60	200	50	Cont.	101	0.45	1350	0.42 (59.5)	1.3	1.0 (142)	9	0.05	0.39 (55.2)
							96	0.41	1625	0.35 (49.6)	1.2	0.69 (97.7)	9	0.05	0.39 (55.2)
		4	60	220	50	Cont.	103	0.46	1375	0.41 (58.1)	1.5	1.2 (170)	11	0.06	0.39 (55.2)
							98	0.40	1650	0.34 (48.1)	1.3	0.87 (123)	11	0.06	0.39 (55.2)

The specifications and wire connections of the round shaft motor are the same as those of the pinion shaft type. For the dimensional outline drawing, refer to page B-221.

Permissible torque at output shaft of gear head

* The speed shown below is a calculated value based on the synchronous rotational speed. Depending on the load, the speed is less than the indicated value by 2% to 20%.

Unit of permissible torque: upper (N·m) / lower (lb·in)

Reduction ratio	3	3.6	5	6	7.5	9	10	12.5	15	18	20	25	30	36	50	60	75	90	100	120	150	180	200		
Speed (r/min)	50 Hz	500	416.7	300	250	200	166.7	150	120	100	83.3	75	60	50	41.7	30	25	20	16.7	15	12.5	10	8.3	7.5	
	60 Hz	600	500	360	300	240	200	180	144	120	100	90	72	60	50	36	30	24	20	18	15	12	10	9	
Applicable gear head	MZ9G3B to MZ9G200B (ball bearing / hinge not attached)	50 Hz	0.98	1.18	1.57	1.96	2.35	2.94	3.14	3.92	4.70	5.59	6.27	7.55	9.11	11.0	15.2	17.8						19.6	(173)
		60 Hz	0.78	0.98	1.37	1.57	1.96	2.35	2.65	3.33	3.92	4.70	5.29	6.47	7.55	9.11	12.6	15.2							19.6
Rotational direction		Same as motor rotational direction						Reverse to motor rotational direction						Same as motor rotational direction											

Permissible torque at output shaft of gear head using decimal gear head

Applicable gear head		Reduction ratio		250	300	360	500	600	750	900	1000	1200	1500	1800
Bearing	Decimal gear head	Speed (r/min)	50 Hz	6	5	4.2	3	2.5	2	1.7	1.5	1.3	1	0.8
				MZ9G□B (ball bearing / Hinge not attached)	MZ9G10XB	Permissible torque	N-m (lb-in)	19.6	19.6	19.6	19.6	19.6	19.6	19.6
MY9G□B (ball bearing / Hinge attached)	7.2	6	5	3.6				3	2.4	2	1.8	1.5	1.2	1
Rotational direction				Reverse to motor rotational direction			Same as motor rotational direction							

Connection diagram

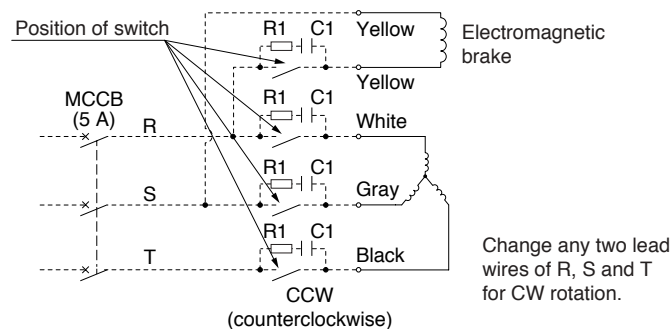

<Note>

- Brake will be activated and held when electromagnetic brake power is turned OFF.
- Protect the contacts by inserting the spark-killer circuit (R1+C1) between the contacts. R1+C1 is provided as an option (DV0P008A, refer to page D-3).
- Use a circuit breaker for the power supply.

Speed-torque characteristics

M9MZ60GB4Y

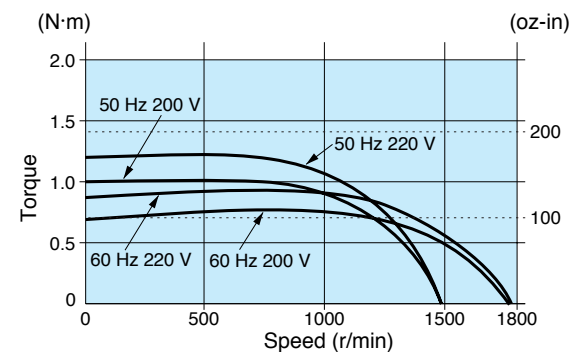

Motor (dimensions)

Scale: 1/4, Unit: mm

M9MZ60GB4Y 4P 60 W 200 V / 220 V (with fan)

Mass	Helical gear	Module	Number of teeth
3.4 kg 7.50 lb		0.6	9

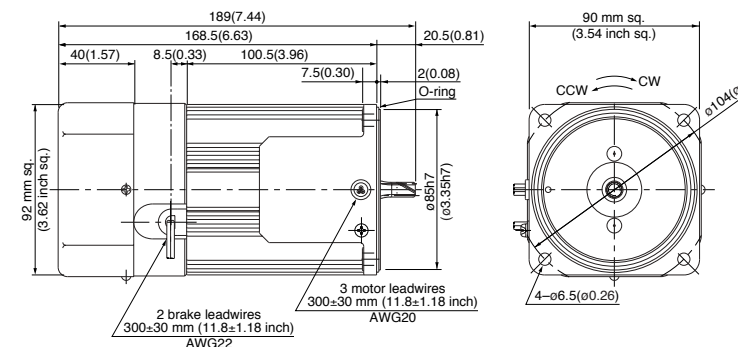

Gear head (dimensions)

Scale: 1/4, Unit: mm (inch)

MZ9G□B (ball bearing / hinge not attached)
Mass 1.4 kg (3.09 lb)

MY9G□B (ball bearing / hinge attached)
Mass 1.4 kg (3.09 lb)

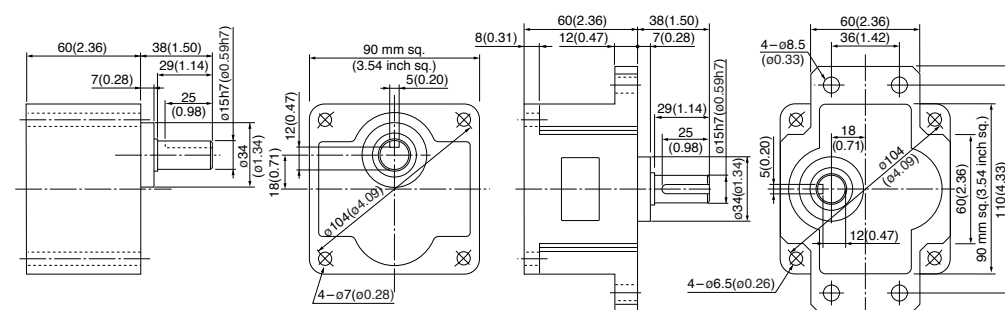

Key and keyway (dimensions) [attachment]

MZ9G□B
MY9G□B

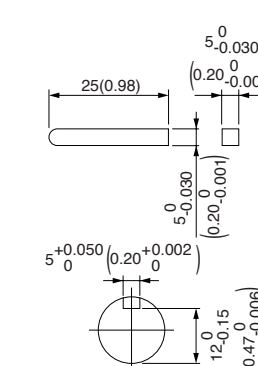

Note) MZ / MY is available for a gear head of either type.

(Note) Because the dimensions may be subject to change, also check the determinate dimensions if the gear head is to be used for design.

Electromagnetic brake 3-phase motor (leadwire)

US CE 90 mm (3.54 inch) sq. 60 W

Specifications

Size	Motor model No.	Number of pole (P)	Output (W)	Voltage (V)	Frequency (Hz)	Rating (min)	Rating				Starting current (A)	Starting torque N·m (oz-in)	Brake Input (W)	Brake Current (A)	Brake Friction Torque N·m (oz-in)			
							Input (W)	Current (A)	Speed (r/min)	Torque N·m (oz-in)								
90 mm sq.	M9MZ60GB4YG M9MZ60GB4YGA	4	60	200	50	Cont.	101	0.45	1350	0.42 (59.5)	1.3	1.0 (142)	9	0.05	0.39 (55.2)			
							96	0.41	1625	0.35 (49.6)	1.2	0.69 (97.7)	9	0.05	0.39 (55.2)			
							220	60	Cont.	98	0.40	1650	0.35 (49.6)	1.3	0.87 (123)	11	0.06	0.39 (55.2)
							230	60	Cont.	98	0.41	1675	0.34 (48.1)	1.4	1.0 (142)	11	0.06	0.39 (55.2)

The specifications and wire connections of the round shaft motor are the same as those of the pinion shaft type. For the dimensional outline drawing, refer to page B-221.
The models with a motor model number to which "A" is suffixed are not sold or available in Japan.

Permissible torque at output shaft of gear head

The speed shown below is a calculated value based on the synchronous rotational speed. Depending on the load, the speed is less than the indicated value by 2% to 20%.

Unit of permissible torque: upper (N·m) / lower (lb-in)

Reduction ratio	Unit of permissible torque: upper (N·m) / lower (lb-in)																							
	3	3.6	5	6	7.5	9	10	12.5	15	18	20	25	30	36	50	60	75	90	100	120	150	180	200	
Speed (r/min)	50 Hz	500	416.7	300	250	200	166.7	150	120	100	83.3	75	60	50	41.7	30	25	20	16.7	15	12.5	10	8.3	7.5
	60 Hz	600	500	360	300	240	200	180	144	120	100	90	72	60	50	36	30	24	20	18	15	12	10	9
Applicable gear head	MZ9G3B to MZ9G200B (ball bearing / hinge not attached)	50 Hz	0.98 (8.7)	1.18 (10.4)	1.57 (13.9)	1.96 (17.3)	2.35 (20.8)	2.94 (26.0)	3.14 (27.8)	3.92 (34.7)	4.70 (41.6)	5.59 (49.5)	6.27 (55.5)	7.55 (66.8)	9.11 (80.6)	11.0 (97.4)	15.2 (135)	17.8 (158)						19.6 (173)
		60 Hz	0.78 (6.9)	0.98 (8.7)	1.37 (12.1)	1.57 (13.9)	1.96 (17.3)	2.35 (20.8)	2.65 (23.5)	3.33 (29.5)	3.92 (34.7)	4.70 (41.8)	5.29 (46.8)	6.47 (57.3)	7.55 (66.8)	9.11 (80.6)	12.6 (112)	15.2 (135)						19.6 (173)
Rotational direction	Same as motor rotational direction						Reverse to motor rotational direction						Same as motor rotational direction											

Permissible torque at output shaft of gear head using decimal gear head

Applicable gear head	Reduction ratio	Unit of permissible torque: upper (N·m) / lower (lb-in)											
		250	300	360	500	600	750	900	1000	1200	1500	1800	
Bearing	Speed (r/min)	50 Hz	6	5	4.2	3	2.5	2	1.7	1.5	1.3	1	0.8
		60 Hz	7.2	6	5	3.6	3	2.4	2	1.8	1.5	1.2	1
MZ9G□B (ball bearing / Hinge not attached) MY9G□B (ball bearing / Hinge attached)	MZ9G10XB	Permissible torque	N·m (lb-in)	19.6 (173)	19.6 (173)	19.6 (173)	19.6 (173)	19.6 (173)	19.6 (173)	19.6 (173)	19.6 (173)	19.6 (173)	19.6 (173)
		Rotational direction	Reverse to motor rotational direction		Same as motor rotational direction								

Connection diagram

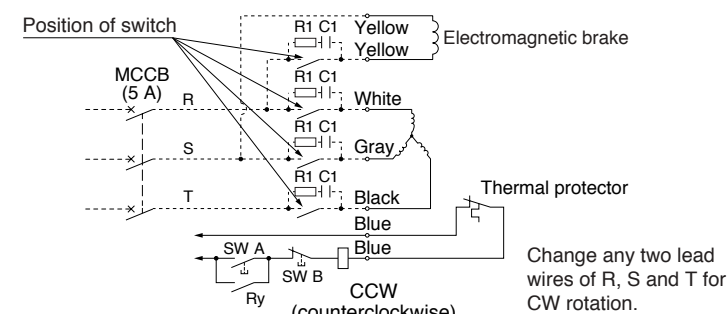

<Note>
1. Brake will be activated and held when electromagnetic brake power is turned OFF.
2. Protect the contacts by inserting the spark-killer circuit (R1+C1) between the contacts. R1+C1 is provided as an option (DV0P008A, refer to page D-3).
3. Refer to page A-58 for connection of thermal protector.
4. Use a circuit breaker for the power supply.

Speed-torque characteristics

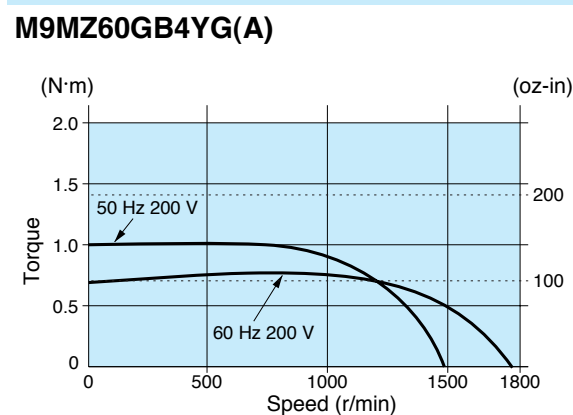

Motor (dimensions)

M9MZ60GB4YG(A) 4P 60 W 200 V / 220 V / 230 V (with fan)

Scale: 1/4, Unit: mm (inch)

Mass 3.4 kg 7.50 lb
Helical gear
Module 0.6
Number of teeth 9

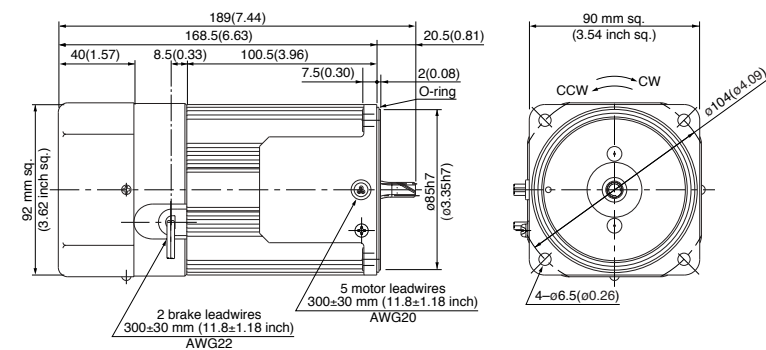

Gear head (dimensions)

Scale: 1/4, Unit: mm (inch)

MZ9G□B (ball bearing / hinge not attached)
Mass 1.4 kg (3.09 lb)

MY9G□B (ball bearing / hinge attached)
Mass 1.4 kg (3.09 lb)

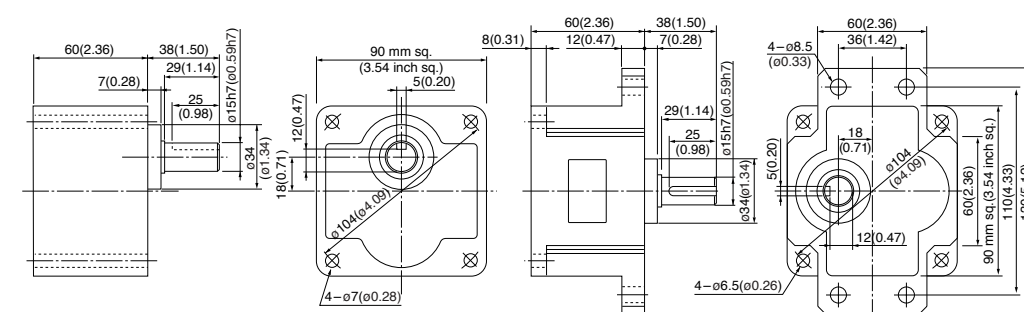

Key and keyway (dimensions) [attachment]

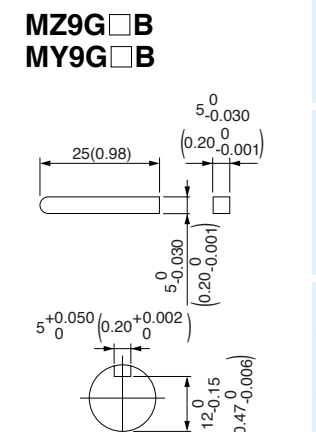

Note) MZ / MY is available for a gear head of either type.

(Note) Because the dimensions may be subject to change, also check the determinate dimensions if the gear head is to be used for design.

Electromagnetic brake 3-phase motor (leadwire)

90 mm (3.54 inch) sq. 90 W

Specifications

Size	Motor model No.	Number of pole (P)	Output (W)	Voltage (V)	Frequency (Hz)	Rating (min)	Rating				Starting current (A)	Starting torque N·m (oz-in)	Brake Input (W)	Brake Current (A)	Brake Friction Torque N·m (oz-in)
							Input (W)	Current (A)	Speed (r/min)	Torque N·m (oz-in)					
90 mm sq.	M9MZ90GB4Y	4	90	200	50	Cont.	141	0.62	1350	0.63 (89.2)	2.0	1.6 (227)	9	0.05	0.39 (55.2)
							137	0.56	1625	0.53 (75.1)	1.8	1.1 (116)	9	0.05	0.39 (55.2)
		4	90	220	50	Cont.	143	0.65	1400	0.62 (87.8)	2.2	2.0 (283)	11	0.06	0.39 (55.2)
							137	0.56	1650	0.52 (73.6)	2.0	1.4 (198)	11	0.06	0.39 (55.2)

* The specifications and wire connections of the round shaft motor are the same as those of the pinion shaft type. For the dimensional outline drawing, refer to page B-221.

Permissible torque at output shaft of gear head

* The speed shown below is a calculated value based on the synchronous rotational speed. Depending on the load, the speed is less than the indicated value by 2 % to 20 %.

Unit of permissible torque: upper (N·m) / lower (lb-in)

Reduction ratio	Unit of permissible torque: upper (N·m) / lower (lb-in)																							
	3	3.6	5	6	7.5	9	10	12.5	15	18	20	25	30	36	50	60	75	90	100	120	150	180	200	
Speed (r/min)	50 Hz	500	416.7	300	250	200	166.7	150	120	100	83.3	75	60	50	41.7	30	25	20	16.7	15	12.5	10	8.3	7.5
	60 Hz	600	500	360	300	240	200	180	144	120	100	90	72	60	50	36	30	24	20	18	15	12	10	9
Applicable gear head	MZ9G3B to MZ9G200B (ball bearing / hinge not attached)	50 Hz	1.37 (12.1)	1.67 (14.8)	2.25 (19.9)	2.74 (24.3)	3.43 (30.4)	4.12 (36.5)	4.51 (39.9)	5.68 (50.3)	6.76 (59.8)	8.04 (71.2)	9.02 (79.8)	10.9 (96.5)	13.0 (115)	15.7 (139)	19.6 (173)							
	MY9G3B to MY9G200B (ball bearing / hinge attached)	60 Hz	1.18 (10.4)	1.37 (12.1)	1.86 (16.5)	2.25 (19.9)	2.84 (25.1)	3.43 (30.4)	3.72 (32.9)	4.70 (41.6)	5.68 (50.3)	6.76 (59.8)	7.55 (66.8)	9.21 (81.5)	10.9 (96.5)	13.0 (115)	18.3 (162)							
Rotational direction	Same as motor rotational direction						Reverse to motor rotational direction						Same as motor rotational direction											

Permissible torque at output shaft of gear head using decimal gear head

Applicable gear head		Reduction ratio	Reduction ratio													
Bearing	Decimal gear head		Speed (r/min)	50 Hz	6	5	4.2	3	2.5	2	1.7	1.5	1.3	1	0.8	
MZ9G□B (ball bearing / hinge not attached)	MZ9G10XB	Permissible torque	N·m	19.6	19.6	19.6	19.6	19.6	19.6	19.6	19.6	19.6	19.6	19.6	19.6	
MY9G□B (ball bearing / hinge attached)			(lb-in)	(173)	(173)	(173)	(173)	(173)	(173)	(173)	(173)	(173)	(173)	(173)	(173)	(173)
Rotational direction			Reverse to motor rotational direction			Same as motor rotational direction										

Connection diagram

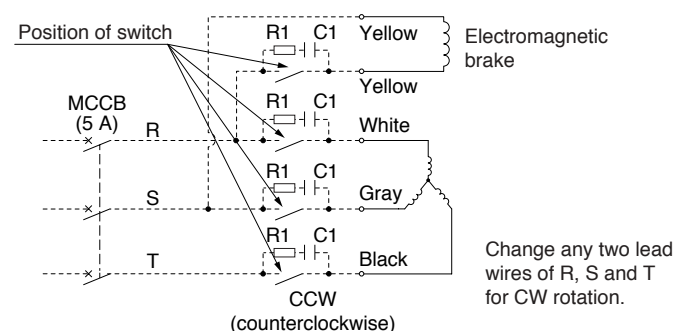

- <Note>**
- Brake will be activated and held when electromagnetic brake power is turned OFF.
 - Protect the contacts by inserting the spark-killer circuit (R1+C1) between the contacts. R1+C1 is provided as an option (DV0P008A, refer to page D-3).
 - Use a circuit breaker for the power supply.

Speed-torque characteristics

M9MZ90GB4Y

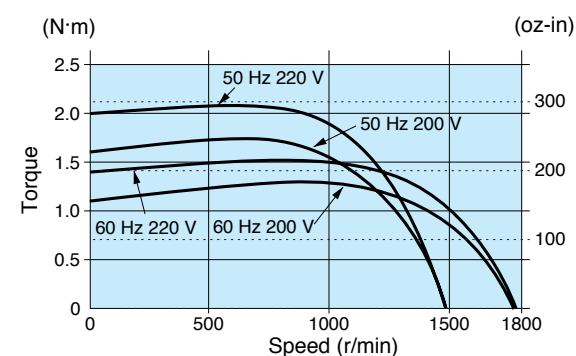

Motor (dimensions)

Scale: 1/4, Unit: mm (inch)

M9MZ90GB4Y 4P 90 W 200 V / 220 V (with fan)

Mass 3.8 kg 8.38 lb
Helical gear
Module 0.6
Number of teeth 9

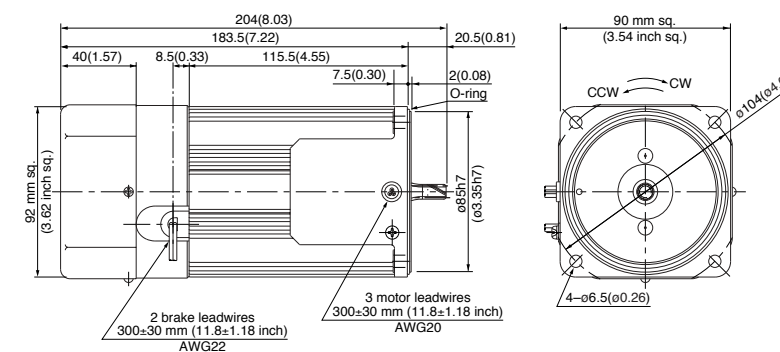

Gear head (dimensions)

Scale: 1/4, Unit: mm (inch)

MZ9G□B (ball bearing / hinge not attached)
Mass 1.4 kg (3.09 lb)

MY9G□B (ball bearing / hinge attached)
Mass 1.4 kg (3.09 lb)

Key and keyway (dimensions) [attachment]

MZ9G□B
MY9G□B

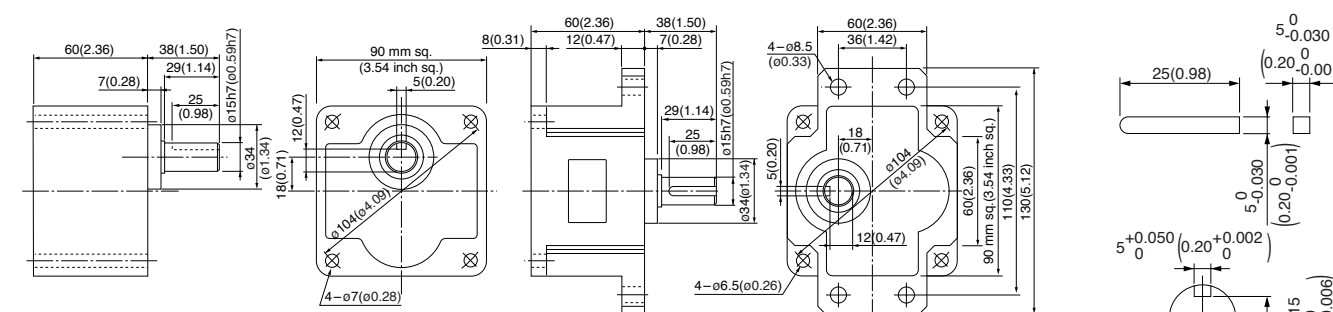

Note) MZ / MY is available for a gear head of either type.

(Note) Because the dimensions may be subject to change, also check the determinate dimensions if the gear head is to be used for design.

Electromagnetic brake 3-phase motor (leadwire)

Specifications

Size	Motor model No.	Number of pole (P)	Output (W)	Voltage (V)	Frequency (Hz)	Rating (min)	Rating				Starting current (A)	Starting torque N·m (oz-in)	Brake Input (W)	Brake Current (A)	Brake Friction Torque N·m (oz-in)
							Input (W)	Current (A)	Speed (r/min)	Torque N·m (oz-in)					
90 mm sq.	M9MZ90GB4YG M9MZ90GB4YGA	4	90	200	50	Cont.	142	0.62	1350	0.63 (89.2)	2.0	1.6 (227)	9	0.05	0.39 (55.2)
							138	0.56	1625	0.53 (75.1)	1.8	1.1 (156)	9	0.05	0.39 (55.2)
							220	0.56	1650	0.52 (73.6)	2.0	1.4 (198)	11	0.06	0.39 (55.2)
							230	0.58	1675	0.51 (72.2)	2.1	1.6 (227)	11	0.06	0.39 (55.2)

* The specifications and wire connections of the round shaft motor are the same as those of the pinion shaft type. For the dimensional outline drawing, refer to page B-221.
 * The models with a motor model number to which "A" is suffixed are not sold or available in Japan.

Permissible torque at output shaft of gear head

* The speed shown below is a calculated value based on the synchronous rotational speed. Depending on the load, the speed is less than the indicated value by 2 % to 20 %.

Unit of permissible torque: upper (N·m) / lower (lb-in)

Reduction ratio	Unit of permissible torque: upper (N·m) / lower (lb-in)																								
	3	3.6	5	6	7.5	9	10	12.5	15	18	20	25	30	36	50	60	75	90	100	120	150	180	200		
Speed (r/min)	50 Hz	500	416.7	300	250	200	166.7	150	120	100	83.3	75	60	50	41.7	30	25	20	16.7	15	12.5	10	8.3	7.5	
	60 Hz	600	500	360	300	240	200	180	144	120	100	90	72	60	50	36	30	24	20	18	15	12	10	9	
Applicable gear head	MZ9G3B to MZ9G200B (ball bearing / hinge not attached) MY9G3B to MY9G200B (ball bearing / hinge attached)	50 Hz	1.37 (12.1)	1.67 (14.8)	2.25 (19.9)	2.74 (24.3)	3.43 (30.4)	4.12 (36.5)	4.51 (39.9)	5.68 (50.3)	6.76 (59.8)	8.04 (71.2)	9.02 (79.8)	10.9 (96.5)	13.0 (115)	15.7 (139)	19.6 (173)								19.6 (173)
		60 Hz	1.18 (10.4)	1.37 (12.1)	1.86 (16.5)	2.25 (19.9)	2.84 (25.1)	3.43 (30.4)	3.72 (32.9)	4.70 (41.6)	5.68 (50.3)	6.76 (59.8)	7.55 (66.8)	9.21 (81.5)	10.9 (96.5)	13.0 (115)	18.3 (162)								19.6 (173)
Rotational direction	Same as motor rotational direction						Reverse to motor rotational direction						Same as motor rotational direction												

Permissible torque at output shaft of gear head using decimal gear head

Applicable gear head		Reduction ratio	Reduction ratio												
Bearing	Decimal gear head		Speed (r/min)	250	300	360	500	600	750	900	1000	1200	1500	1800	
MZ9G□B (ball bearing / hinge not attached) MY9G□B (ball bearing / hinge attached)	MZ9G10XB	50 Hz	6	5	4.2	3	2.5	2	1.7	1.5	1.3	1	0.8		
		60 Hz	7.2	6	5	3.6	3	2.4	2	1.8	1.5	1.2	1		
Permissible torque		N·m (lb-in)	19.6 (173)	19.6 (173)	19.6 (173)	19.6 (173)	19.6 (173)	19.6 (173)	19.6 (173)	19.6 (173)	19.6 (173)	19.6 (173)	19.6 (173)		
Rotational direction			Reverse to motor rotational direction			Same as motor rotational direction									

Connection diagram

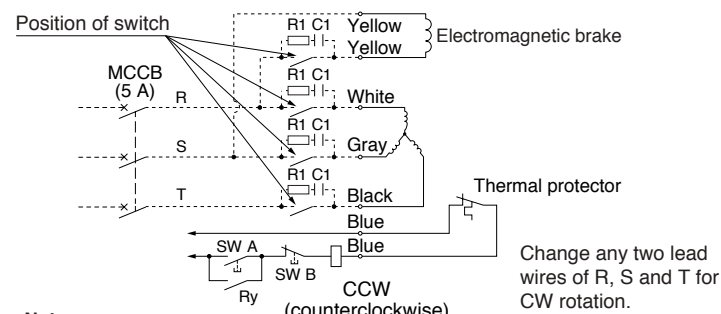

<Note>
 1. Brake will be activated and held when electromagnetic brake power is turned OFF.
 2. Protect the contacts by inserting the spark-killer circuit (R1+C1) between the contacts. R1+C1 is provided as an option (DV0P008A, refer to page D-3).
 3. Refer to page A-58 for connection of thermal protector.
 4. Use a circuit breaker for the power supply.

Speed-torque characteristics

M9MZ90GB4YG(A)

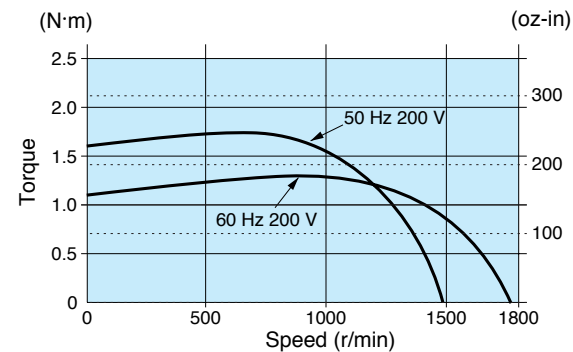

Motor (dimensions)

Scale: 1/4, Unit: mm (inch)

M9MZ90GB4YG(A) 4P 90 W 200 V / 220 V / 230 V (with fan)

Mass	Helical gear	Module	Number of teeth
3.8 kg (8.38 lb)	gear	0.6	9

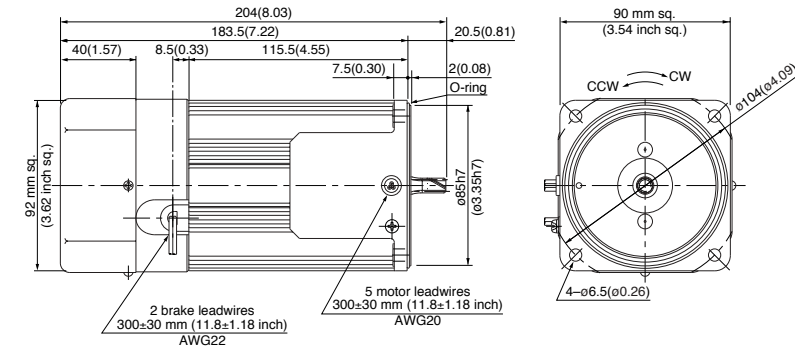

Gear head (dimensions)

Scale: 1/4, Unit: mm (inch)

MZ9G□B (ball bearing / hinge not attached)
 Mass 1.4 kg (3.09 lb)

MY9G□B (ball bearing / hinge attached)
 Mass 1.4 kg (3.09 lb)

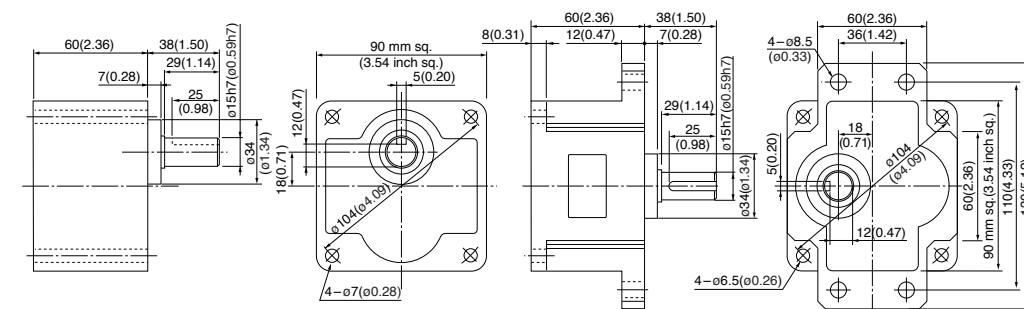

Key and keyway (dimensions) [attachment]

MZ9G□B
 MY9G□B

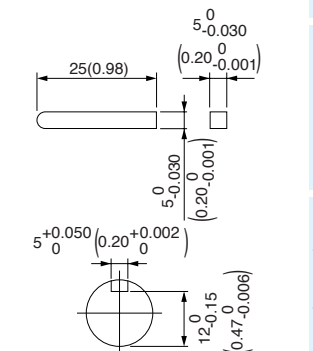

Note) MZ / MY is available for a gear head of either type.

(Note) Because the dimensions may be subject to change, also check the determinate dimensions if the gear head is to be used for design.

Induction motor
 Reversible motor
 3-phase motor
 Electromagnetic brake motor
 Variable speed induction motor
 Variable speed reversible motor
 Variable speed electromagnetic brake single-phase motor
 Variable speed unit motor
 C&B motor
 2-pole round shaft motor
 Gear head
 Gear head -inch (U.S.A.)

Electromagnetic brake single-phase motor (leadwire)

Gear head combination dimensions

Scale: 1/4, Unit: mm (inch)

* Gear head is sold separately.

60 mm sq. (2.36 inch sq.) 6 W

- M6RX6GB4L + MX6G□BA(MA) / MX6G□B(M)
- M6RX6GB4Y + MX6G□BA(MA) / MX6G□B(M)
- M6RX6GB4LG(A) + MX6G□BA(MA) / MX6G□B(M)
- M6RX6GB4DG(A) + MX6G□BA(MA) / MX6G□B(M)
- M6RX6GB4YG(A) + MX6G□BA(MA) / MX6G□B(M)
- M6RX6GB4GG(A) + MX6G□BA(MA) / MX6G□B(M)

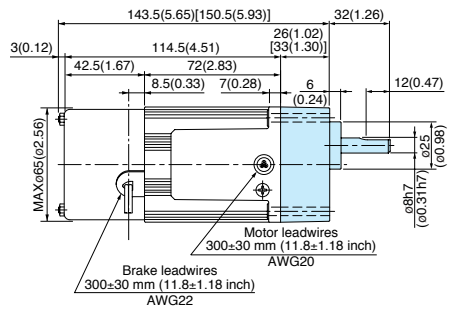

* Figures in [] represent the dimensions of MX6G□B (M) (1/30 or larger reduction ratio).

The model number of the gear head with a reduction ratio of 1/25 or smaller is MX6G□BA (MA).

70 mm sq. (2.76 inch sq.) 15 W

- M7RX15GB4L + MX7G□BA(MA) / MX7G□B(M)
- M7RX15GB4Y + MX7G□BA(MA) / MX7G□B(M)
- M7RX15GB4LG(A) + MX7G□BA(MA) / MX7G□B(M)
- M7RX15GB4DG(A) + MX7G□BA(MA) / MX7G□B(M)
- M7RX15GB4YG(A) + MX7G□BA(MA) / MX7G□B(M)
- M7RX15GB4GG(A) + MX7G□BA(MA) / MX7G□B(M)

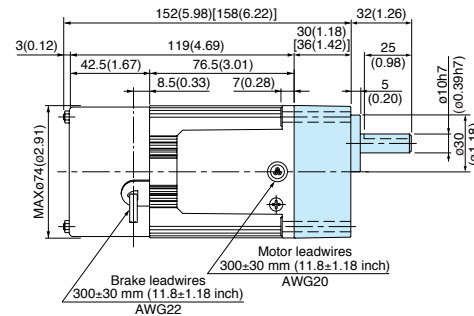

* Figures in [] represent the dimensions of MX7G□B (M) (1/30 or larger reduction ratio).

The model number of the gear head with a reduction ratio of 1/25 or smaller is MX7G□BA (MA).

80 mm sq. (3.15 inch sq.) 25 W

- M8RX25GB4L + MX8G□B(M)
- M8RX25GB4Y + MX8G□B(M)
- M8RX25GB4LG(A) + MX8G□B(M)
- M8RX25GB4DG(A) + MX8G□B(M)
- M8RX25GB4YG(A) + MX8G□B(M)
- M8RX25GB4GG(A) + MX8G□B(M)

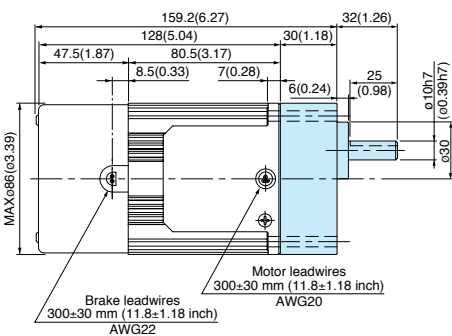

90 mm sq. (3.54 inch sq.) 40 W

- M9RX40GB4L + MX9G□B(M)
- M9RX40GB4Y + MX9G□B(M)
- M9RX40GB4LG(A) + MX9G□B(M)
- M9RX40GB4DG(A) + MX9G□B(M)
- M9RX40GB4YG(A) + MX9G□B(M)
- M9RX40GB4GG(A) + MX9G□B(M)

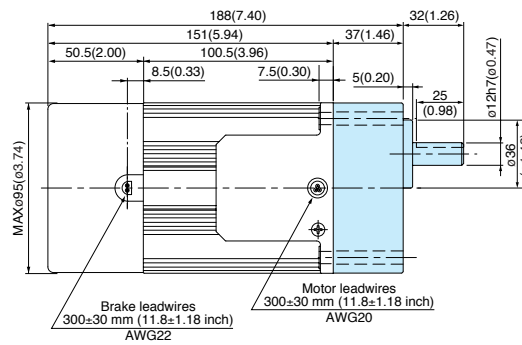

90 mm sq. (3.54 inch sq.) 60 W

- M9RZ60GB4L + MZ9G□B (MY9G□B)
- M9RZ60GB4Y + MZ9G□B (MY9G□B)
- M9RZ60GB4LG(A) + MZ9G□B (MY9G□B)
- M9RZ60GB4DG(A) + MZ9G□B (MY9G□B)
- M9RZ60GB4YG(A) + MZ9G□B (MY9G□B)
- M9RZ60GB4GG(A) + MZ9G□B (MY9G□B)

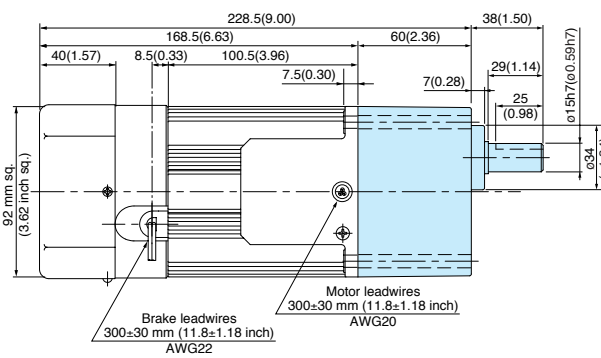

* Refer to page B-444 for high torque gear head.

90 mm sq. (3.54 inch sq.) 90 W

- M9RZ90GB4L + MY9G□B (MZ9G□B)
- M9RZ90GB4Y + MY9G□B (MZ9G□B)
- M9RZ90GB4LG(A) + MY9G□B (MZ9G□B)
- M9RZ90GB4DG(A) + MY9G□B (MZ9G□B)
- M9RZ90GB4YG(A) + MY9G□B (MZ9G□B)
- M9RZ90GB4GG(A) + MY9G□B (MZ9G□B)

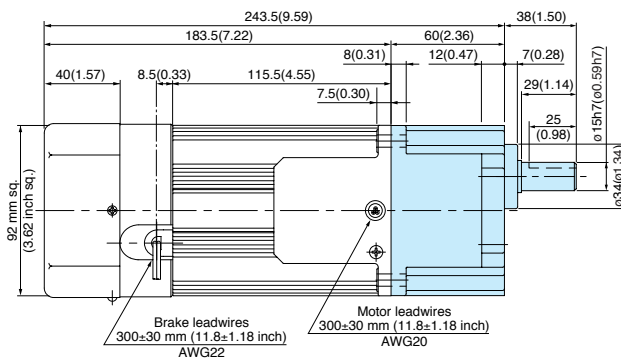

* Refer to page B-444 for high torque gear head.

* Please read your User's manual carefully so that you will understand the operation and safety precautions before attempting to operate the system.

Electromagnetic brake 3-phase motor (leadwire)

Gear head combination dimensions

Scale: 1/4, Unit: mm (inch)

* Gear head is sold separately.

80 mm sq. (3.15 inch sq.) 25 W

- M8MX25GB4Y + MX8G□B(M)
- M8MX25GB4YG(A) + MX8G□B(M)

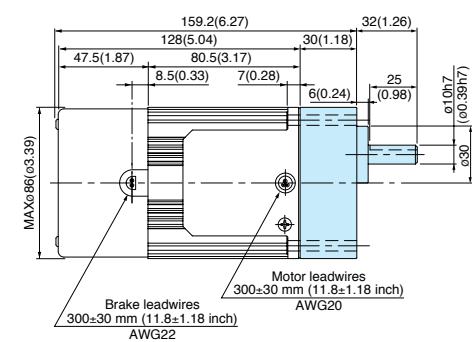

90 mm sq. (3.54 inch sq.) 40 W

- M9MX40GB4Y + MX9G□B(M)
- M9MX40GB4YG(A) + MX9G□B(M)

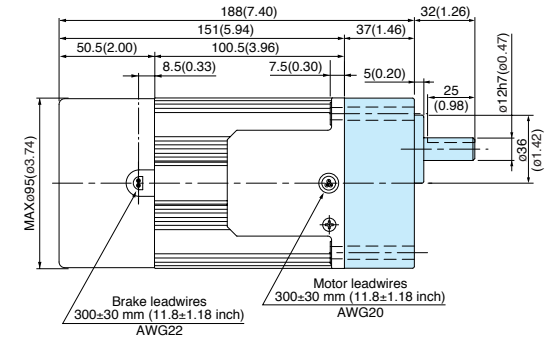

90 mm sq. (3.54 inch sq.) 60 W

- M9MZ60GB4Y + MZ9G□B (MY9G□B)
- M9MZ60GB4YG(A) + MZ9G□B (MY9G□B)

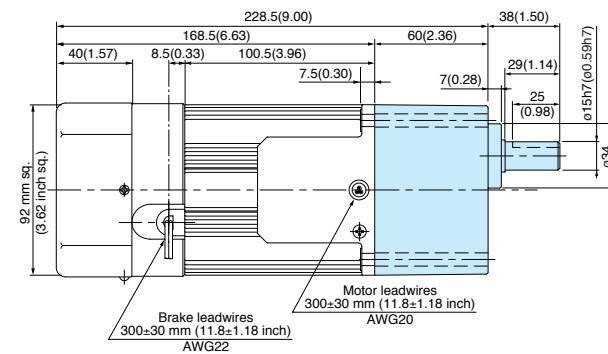

* Refer to page B-444 for high torque gear head.

90 mm sq. (3.54 inch sq.) 90 W

- M9MZ90GB4Y + MY9G□B (MZ9G□B)
- M9MZ90GB4YG(A) + MY9G□B (MZ9G□B)

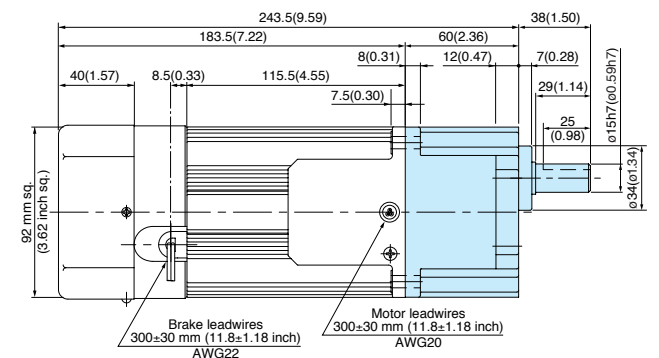

* Refer to page B-444 for high torque gear head.

* The models with a motor model number to which "A" is suffixed are not equipped with a capacitor cap.

* The models with a motor model number to which "A" is suffixed are not sold or available in Japan.

(Note) Because the dimensions may be subject to change, also check the determinate dimensions if the gear head is to be used for design.

Induction motor
Reversible motor
3-phase motor
Electromagnetic brake motor
Variable speed induction motor
Variable speed reversible motor
Variable speed electromagnetic brake single-phase motor
Variable speed unit motor
C&B motor
2-pole round shaft motor
Gear head
Gear head -inch (U.S.A.)

Electromagnetic brake single-phase motor (4-pole round shaft / leadwire)

Dimensions
Scale: 1/4, Unit: mm (inch)

60 mm sq. (2.36 inch sq.) 6 W **Mass**
1.0 kg (2.20 lb)
M6RX6SB4LS M6RX6SB4LG(A)
M6RX6SB4YS M6RX6SB4DG(A)
M6RX6SB4YG(A)
M6RX6SB4GG(A)

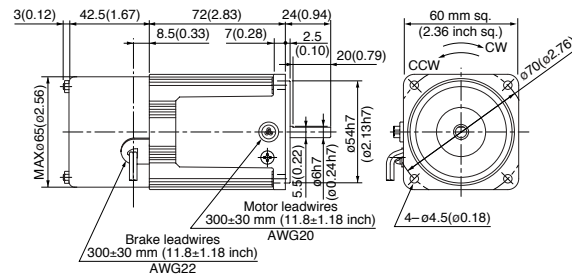

70 mm sq. (2.76 inch sq.) 15 W **Mass**
1.5 kg (3.31 lb)
M7RX15SB4LS M7RX15SB4LG(A)
M7RX15SB4YS M7RX15SB4DG(A)
M7RX15SB4YG(A)
M7RX15SB4GG(A)

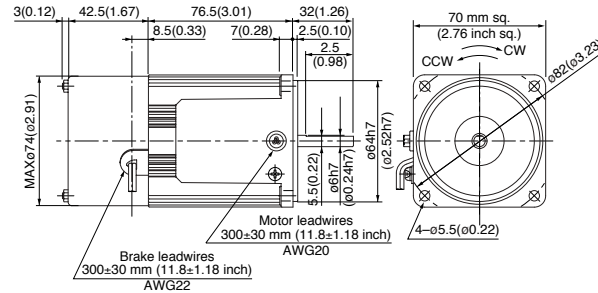

80 mm sq. (3.15 inch sq.) 25 W **Mass**
2.1 kg (4.63 lb)
M8RX25SB4LS M8RX25SB4LG(A)
M8RX25SB4YS M8RX25SB4DG(A)
M8RX25SB4YG(A)
M8RX25SB4GG(A)

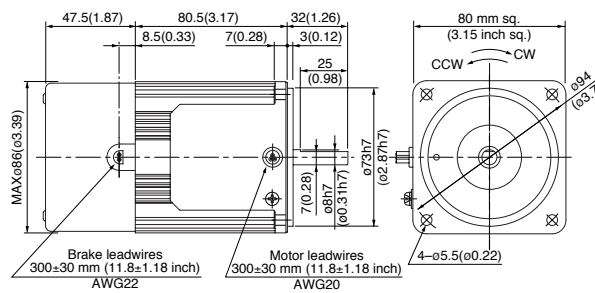

90 mm sq. (3.54 inch sq.) 40 W **Mass**
3.2 kg (7.05 lb)
M9RX40SB4LS M9RX40SB4LG(A)
M9RX40SB4YS M9RX40SB4DG(A)
M9RX40SB4YG(A)
M9RX40SB4GG(A)

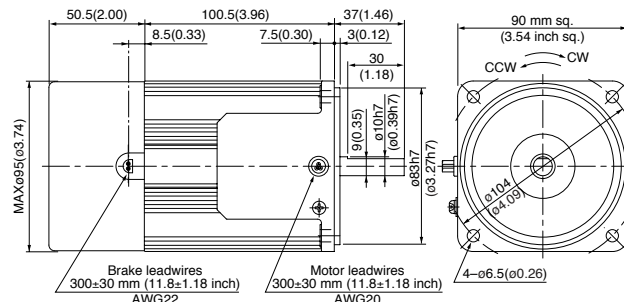

90 mm sq. (3.54 inch sq.) 60 W **Mass**
3.4 kg (7.50 lb)
M9RZ60SB4LS (with fan) M9RZ60SB4LG(A) (with fan)
M9RZ60SB4YS (with fan) M9RZ60SB4DG(A) (with fan)
M9RZ60SB4YG(A) (with fan)
M9RZ60SB4GG(A) (with fan)

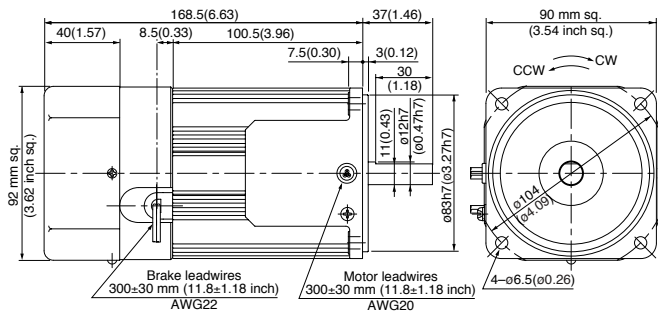

90 mm sq. (3.54 inch sq.) 90 W **Mass**
3.8 kg (8.38 lb)
M9RZ90SB4LS (with fan) M9RZ90SB4LG(A) (with fan)
M9RZ90SB4YS (with fan) M9RZ90SB4DG(A) (with fan)
M9RZ90SB4YG(A) (with fan)
M9RZ90SB4GG(A) (with fan)

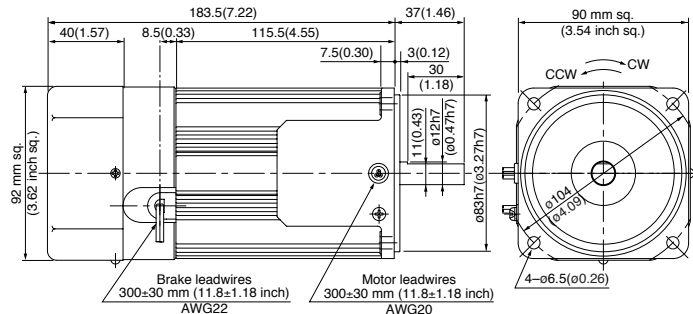

* Please refer to the pinion shaft motor for wiring and specifications of the motor.

* The models with a motor model number to which "A" is suffixed are not equipped with a capacitor cap.
* The models with a motor model number to which "A" is suffixed are not sold or available in Japan.

* Please read your User's manual carefully so that you will understand the operation and safety precautions before attempting to operate the system.

Features B-168 System configuration B-169 Coding system B-169 Model list B-174

Electromagnetic brake 3-phase motor (4-pole round shaft / leadwire)

Dimensions
Scale: 1/4, Unit: mm (inch)

80 mm sq. (3.15 inch sq.) 25 W **Mass**
2.1 kg (4.63 lb)
M8MX25SB4YS
M8MX25SB4YG(A)

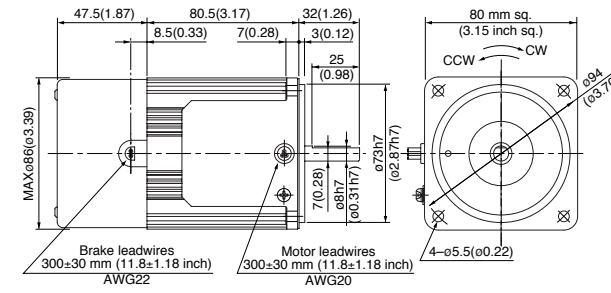

90 mm sq. (3.54 inch sq.) 60 W **Mass**
3.4 kg (7.50 lb)
M9MZ60SB4YS (with fan)
M9MZ60SB4YG(A) (with fan)

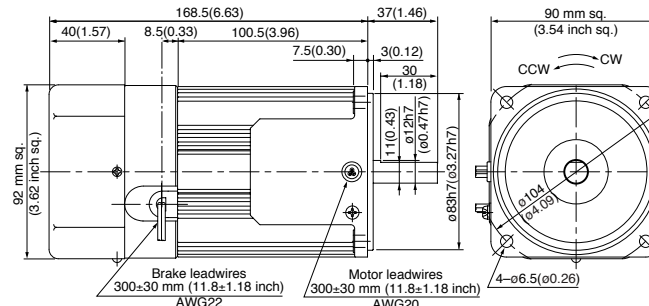

90 mm sq. (3.54 inch sq.) 40 W **Mass**
3.2 kg (7.05 lb)
M9MX40SB4YS
M9MX40SB4YG(A)

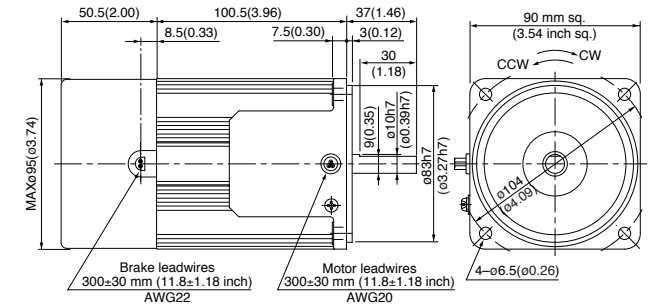

90 mm sq. (3.54 inch sq.) 90 W **Mass**
3.8 kg (8.38 lb)
M9MZ90SB4YS (with fan)
M9MZ90SB4YG(A) (with fan)

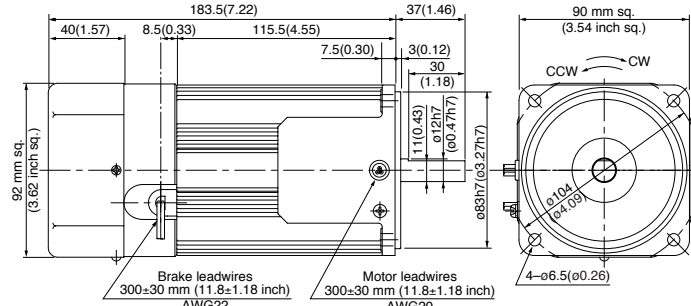

* Please refer to the pinion shaft motor for wiring and specifications of the motor.

(Note) Because the dimensions may be subject to change, also check the determinate dimensions if the gear head is to be used for design.

Specifications B-178 to B-217 Controls C-4 Option D-2

Induction motor
Reversible motor
3-phase motor
Electromagnetic brake motor
Variable speed induction motor
Variable speed reversible motor
Variable speed electromagnetic brake single-phase motor
Variable speed unit motor
C&B motor
2-pole round shaft motor
Gear head
Gear head - inch (U.S.A.)

