

# DELPHI

THREE PHASE MOTORS

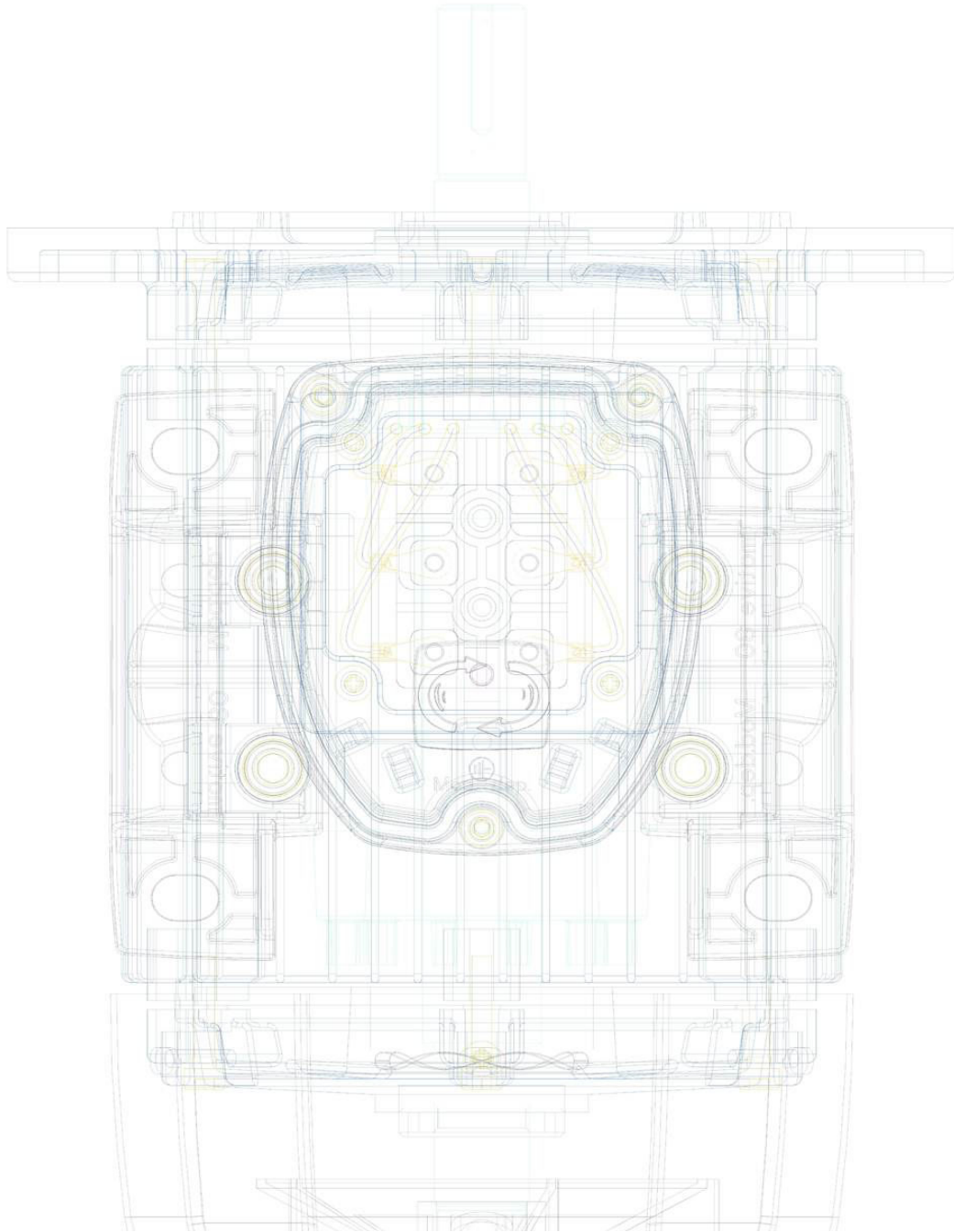

# Technical manual



## Technical characteristics

Rotomotive motors are built according to international standard regulations for universal use; each frame size throughout the construction is calculated with reference to the tables of Indian standard IS : 1231, IS:2223 & International standard IEC 72-1; The mounting position as per IS : 2253 and IEC 34-7, are B3, B5, B14, B35.



Rotomotive asynchronous three-phase are closed and externally ventilated. Frames up to and 132 included, are made in die cast aluminium alloy, from frame 160 the frame is made in cast iron. All technical details, performance data and dimensions, are detailed in the product catalogue and in [www.rotomotive.com](http://www.rotomotive.com)

**All three-phase motors are multiple voltage, and multiple frequency 50/60Hz, according to the data on the right F Class insulation, Continuous duty service S1\*, IP55 protection Efficiency is classified on the name plate IE2/IE3 according to the norm IEC 60034-30**

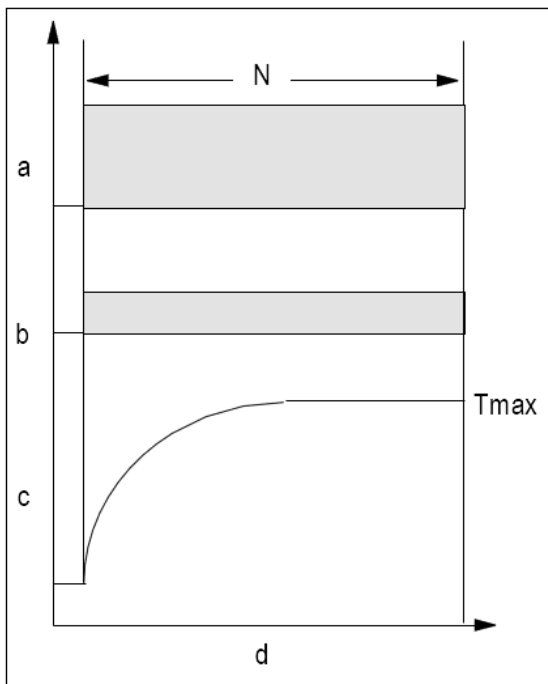
\*S1 - Continuous duty service: operating at constant load



a= load  
 b= electric losses  
 c= temperature  
 d= time  
 N= steady load operating time  
 Tmax= max temperature

KW	Hz	Volts		
				Tolerance
Up to 2.2 KW	50±5%	230	400	+ 14 / -7 %
		220	380	+ 15 / -2 %
		240	415	+ 10 / -10 %
	60±5%	260	440	+ 15 / -6 %
		265	460	+ 10 / -10 %
		280	480	+ 5 / -14 %
Above 2.2 KW	50±5%	400	690	+ 14 / -7 %
		380	660	+ 15 / -2 %
		415	720	+ 10 / -10 %
	60±5%	440	760	+ 15 / -6 %
		460	795	+ 10 / -10 %
		480	830	+ 5 / -14 %

## Electrical and thermal protections

Protections must be chosen based on the specific running conditions, according to standards EN 60204-1 (for Flame proof motors, see also EN60079-14 and EN61241-14).

### External protections

It is possible to have:



1. Protection against overloads. A thermal cut-out relay, which automatically controls a knife switch.



2. Protection against peak currents by magnetic relay that controls an automatic knife switch, or by fuses; these must be set to the locked rotor current.

3. if the application requires protection against excessive speed of the electric motor, for instance if the mechanical load may drive the electric motor itself and thereby create a hazardous situation.

4. If special conditions or synchronized operation with other machines or parts of machines require it, protection against power failures or dips by means of a minimum voltage relay that controls an automatic power knife switch.

## Inner thermal overload cut-out switches

(per CEI 2-3/IEC 34-1)

The electrical protections on the motor power line may not be sufficient to protect against overloads. If the cooling conditions worsen, the motor overheats but the electrical conditions do not change. This inhibits line protections. Installing built-in protections on the windings solves this problem:

### Bimetallic thermal overload protection (TOP)

This is a normally-closed electromechanical device that opens when the threshold temperature is reached; it automatically resets when the temperature falls below the threshold level. Bimetallic devices are available with various operating temperatures and without automatic reset, per EN 60204-1.

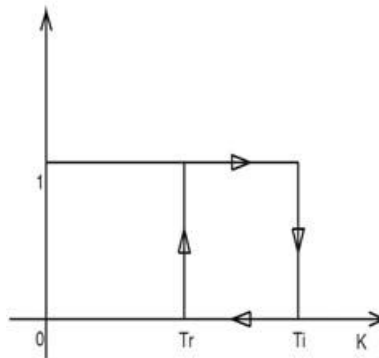

Tr= Opening temperature (motor stops)

Ti= Re-closing temperature (motor works again)

### PTC thermistor

And all motors from frame 160 to frame 355L are equipped with 3 PTC thermistors in the winding, with temperature intervention of 120-130°C in Class F motors (standard) (150-160°C in H Class motors,)

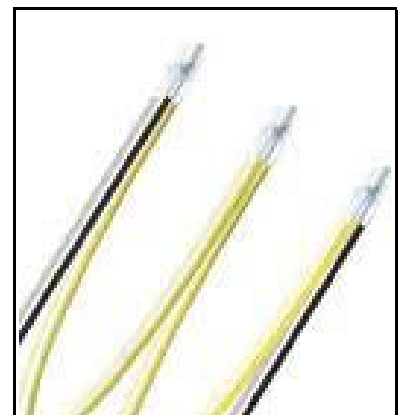

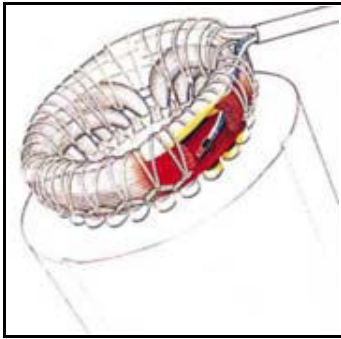

PTC position

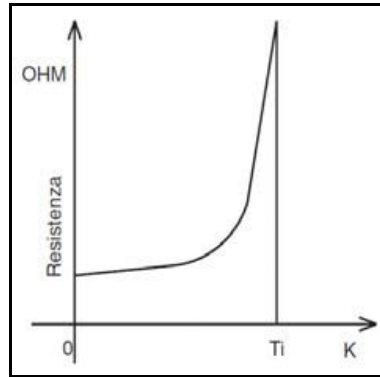

Ti= activating temperature

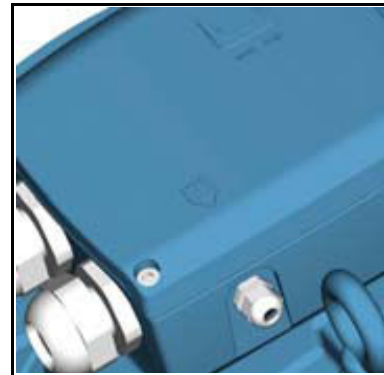

Size 160-400  
PTC cable gland

**PT100**

This is a device that continuously, increasingly adjusts its resistance according to the temperature. It is useful for constant measuring of the winding temperatures using electronic

In compliance with IEC34-1, all motors can be exposed to overload conditions of 1,5 times the rated current for 2 min and 1,6 times the rated torque for 15 sec (at rated V and Hz)

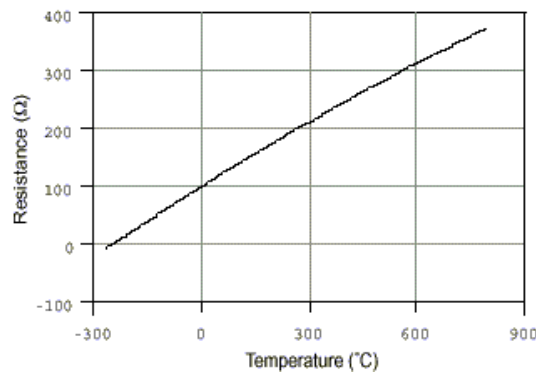
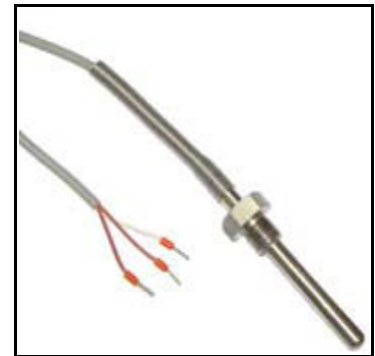

According to IEC34-1 norm, all motors withstand a temporary overload of 1.5 times the rated supply system must then not be able to automatically restart the motor.

## Electrical connection

**The operations for the connection to the electric network** (valid for auxiliary circuits, too) must be performed in compliance with the following indications:

- any operation on the plant must be run by trained personnel;
- the motor must be disabled and isolated;
- make sure that a casual start can not occur;
- make sure that there is no voltage;
- If the network does not sustain the direct input voltage, the motor can be started by means of a star/delta commutator, which is possible only in motors where the connection of the winding for rated voltage is delta.
- the electric connection must be made in order be long-lasting and safe;
- assure correct dimensioning of power supply cables
- make sure that in the box for the connection there is neither foreign bodies, nor dirty/humid parts. Close the unused cable glands and tight terminal box lid in order to prevent the entrance of dust and water;
- when testing without output components secure the keyway;
- in motors with brake (AT.. series), please verify the brake switching before the starting process;
- you can change to counter-rotation an be obtained by interchanging the two phases

### Wiring Diagrams (DELPHI 3PH)

Motor Type	56	63-100	112	132	160-180	200-225	250-355	400
Cable Gland	M16	M20	M25	M32	2xM40	2xM50	2xM63	2xM63
Cables diam mm	'3-7	'10-14	'9-16	13-20	20-26	25-31	29-35	29-35

Correct and wrong connection of the power cables terminal lugs to the terminal block:

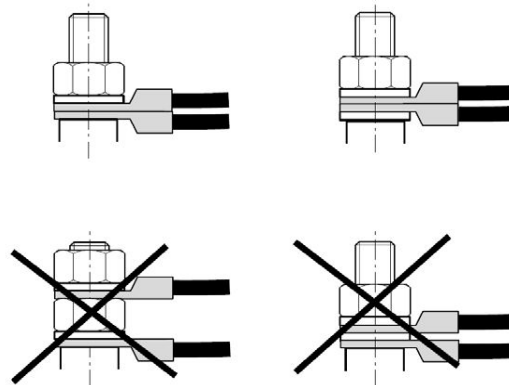

Torque (Nm) on the terminal block nuts

 Nm	M4	M5	M6	M8	M10	M12	M16
	steel	2	3.2	5	10	20	35
brass	1	2	3	6	12	20	50

Delphi series three phase motors can be connected “Star” or “Delta” .

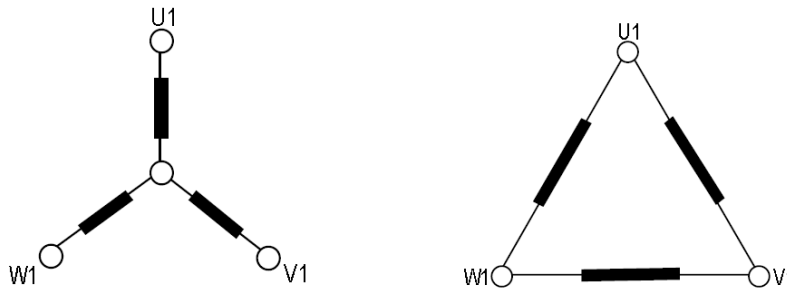

### Star connection

**Star connection is obtained by connecting together the terminals W2, U2, V2 and supplying the terminals U1, V1, W1.**

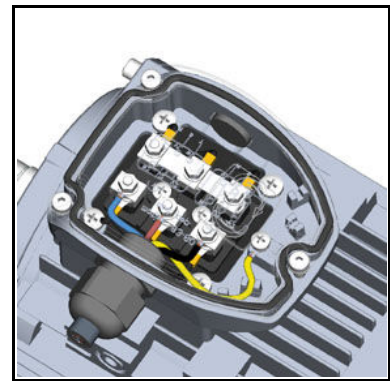

### Delta connection

**Delta connection is obtained by connecting the end of a phase with the beginning of the following one.**

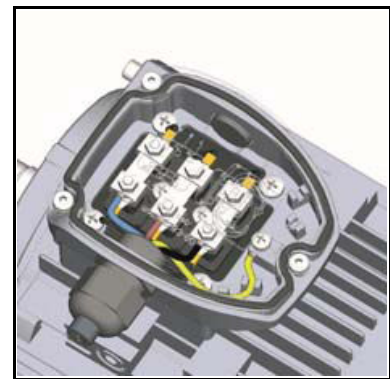

## Start

Before starting make an overall check of the motor to make sure that all the indications about installation have been applied. In particular

- make sure that the voltage of the motor is equivalent to the one expected (see motor plate) and
- check the union of the connecting link, close all its dies and secure the cover of the terminal board without damaging the gasket;
- verify the free rotation of the motor shaft manually;
- check if there is voltage in all the phases and eventually measure their value to check their conformity to the plate values.

## Working conditions

**Humidity:** The electrical equipment must be able to work with a relative humidity between 30 and 95% (without condensation). Damaging effects of occasional condensation must be avoided by adequate equipment design or, if necessary, by additional measures (for example, built-in heating device, drainage holes). The winding are vacuum pressure impregnated (VPI process, evaporation free, medium category), and are therefore suitable for tropical climates



**Altitude and temperature:** the powers indicated are intended for regular use at altitudes below 1000 mt above sea level and a temperature between +5°C and +40°C for motors

having a rated power below 0.6 kW, or between -15°C and 40°C for motors having a rated power equal

to or greater than 0.6 kW (IEC 34-1): For higher altitude and/or temperature the power decreases of 10%

each 10°C of higher temperature, and of 8% for each 1000 mt of higher altitude. It is not allowed to use

motors designed for explosive atmospheres in environment temperatures out of -20°C and +40°C range.

**Voltage - Frequency:** The maximum variation of the supply voltage is +-10%. Within this tolerance

Rotomotive motors supply the rated power. Within such range, the temperature rise of the motor can fluctuate up to +/-20°C

**Insulation:** the stator winding is made of resin coated copper wire and insulation materials in F class,

that provide high protection against electrical and mechanical stresses.

The max temperatures (Tmax) for insulation classes defined by EN 60034-1 standard are

Class	$\Delta T$ (°C)	T max (°C)
A	60 + 5 °	105
E	75+5°	120
B	80+5°	130
F	105+5°	155
H	125	180

The temperature rise of the Delphi series is class B or lower, much under the limits of F class motors, thus permitting a longer motor life.



## Rain shield

For outdoor applications with V5 – V18 – V1 – V15 installation (shaft down), we recommend to mount a rain shield. This configuration may also be used in textiles processing industry.

TYPE	L
63	215
71	323
80	369
90S	403
90L	428
100	469
112	453
132S	573
132M	613
160M	770
160L	825
180M	915
180L	955
200L	1025
225S	1155
225M	1160
250M	1220
280S	1265
280M	1315
315S	1540
315M	1570
315L	1680
355M	1840
355L	1870

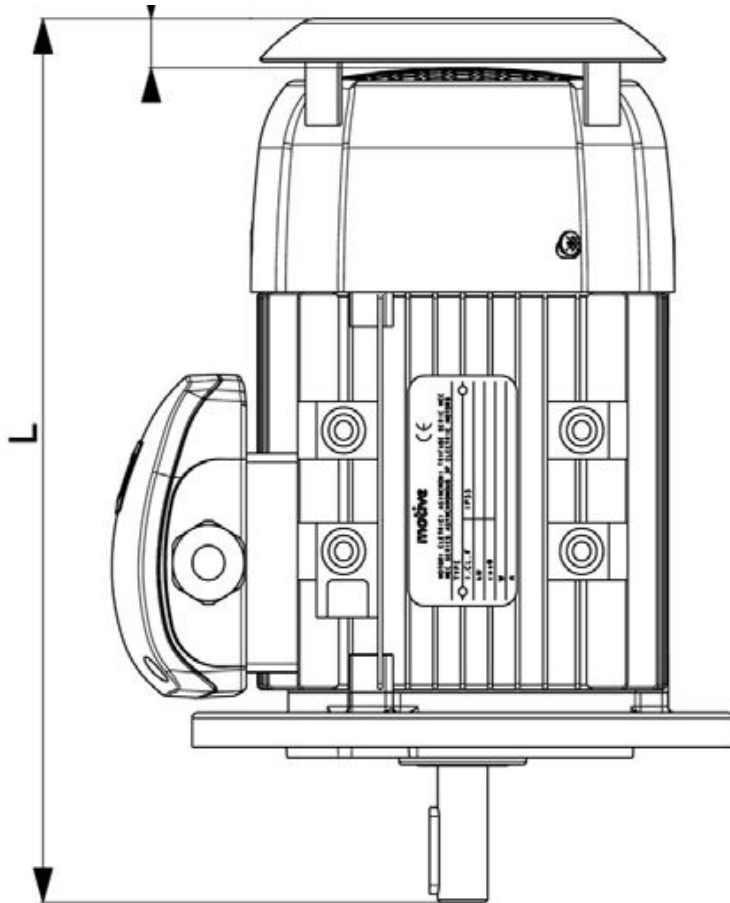

## AT.. Delphi series

Delphi ATDC, AT24, and ATAC series are of electromagnetic type and normally OFF i.e. the braking action is occurs in the absence of power supply. The brake insulation class F. All brake assemblies are protected against corrosion by painting or heat galvanizing and resined winding.

AT24 series motors use DC electromagnetic brakes with 24Vdc input type which can be operated through an inverter(usually having 24Vdc port).

Two different types of adjustment are possible for motors ATDC ,AT24 and ATAC motors.

### S air gap adjustment

For proper operation, the air gap  $S$  between electromagnet (7) and the mobile armature (1) must be between the following indicated limits:

Motor type (ATDC /AT24)	S air gap (mm)	Motor type (ATAC)	S air gap (mm)
63~71	0.40~0.50	63~71	0.2
80~160	0.50~0.60	80~160	0

The adjustment is made by using the threaded bushes (10), using a thickness gauge to ensure that the required air gap is maintained.

### Braking torque adjustment

The braking torque can be increased by tightening the adjuster screws (9)(ATDC/ATAC motor) or on the knob(11)(AT24 motor). The setting has already been made by Rotomotive at the max value, and therefore we suggest to not to intervene on it

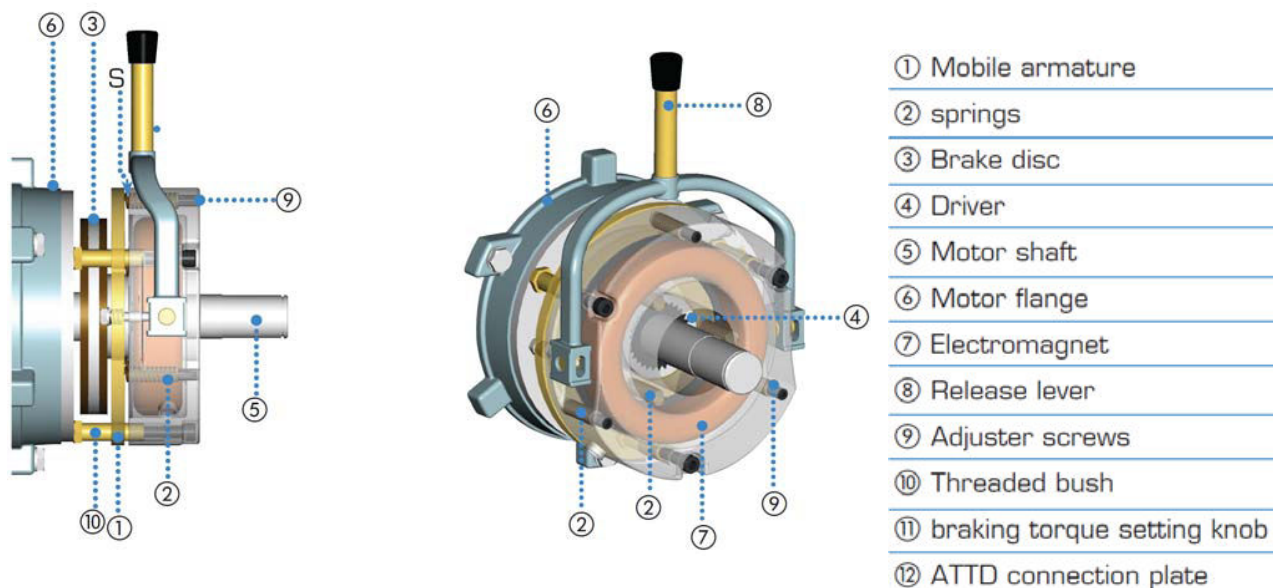

ATDC brakes are DC brakes power supplied by a rectifier installed inside the motor main terminal box. The performance of all brakes, in terms of Watt, Nm and speed in mSec are shown in Rotomotive website [www.Rotomotive.com](http://www.Rotomotive.com)

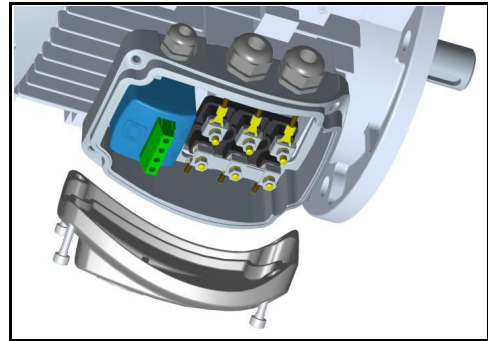

The following table chart shows the tensions on the rectifier and the brake of ATDC model

TYPE	Input voltage on rectifier (Vac)	Output voltage to brake (Vdc)
ATDC63-100	220-280	99-126
ATDC 112-160	380-480	171-216

Unless there's a different request of the client, Rotomotive supplies ATDC brake motors with the rectifier already connected directly to the main terminal block of the motor, in order to permit to the motor switching to act at the same time on the brake.

### Manual release

Rotomotive brake motors are supplied with the manual release lever in their standard version. If not wished, the lever is like a screw, that can be taken away simply turning it.

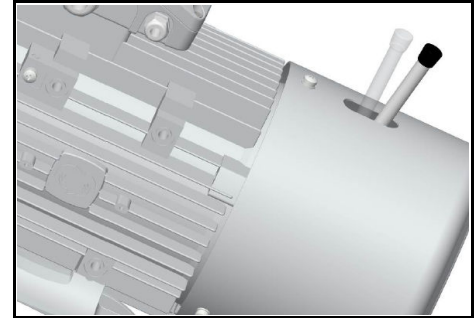

### IP

AT.. brakes are IP66 under an electrical point of view, but mechanically, in case of an outdoor use, they should be protected by rust and by disc adhesion effects given by humidity. In such a case, we suggest to use our protective rubber ring seals

This device prevents the exit or ingress of dust, humidity, dirt, etc., out of or into the braking area.

It is inserted into the groove on the stator. If your brake doesn't have such a groove, you must order a specifically machined brake for that.

In order to safeguard the braking torque, it is necessary to clean periodically the parts inside the rubber ring seal by the dust created by the disc lining.

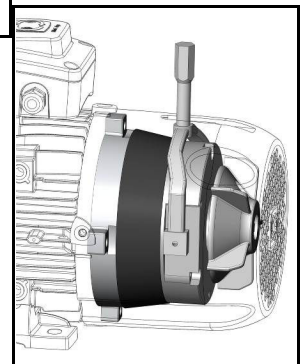
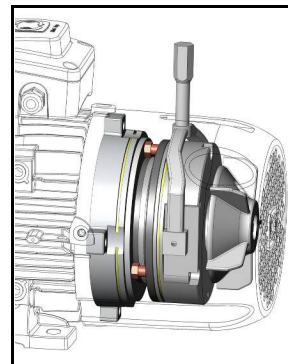

### Assisted power cooling

For applications where the motor will be operated below frequency of 25Hz and above 60Hz, the appropriate assisted power cooling must be mounted as there are too many variables involved to determine the various possible thermal duties and thus the temperature reached by the motors.

TYPE	POWER W	CAPACITY m <sup>3</sup> / h	L
63	21	140	300
71	30	300	320
80	35	350	366
90S	50	500	400
90L	50	500	425
100	65	650	468
112	65	1000	450
132S	90	880	570
132M	90	880	610
160M	90	1100	710
160L	90	1100	765
180M	100	1200	805
180L	100	1200	845
200L	180	2500	910
225S	200	3800	1035
225M	200	3800	1040
250M	320	4200	1110
280S	370	5000	1160
280M	370	5000	1210
315S	500	6000	1410
315M	500	6000	1440
315L	500	6000	1550
355M	600	6500	1735
355L	600	6500	1765

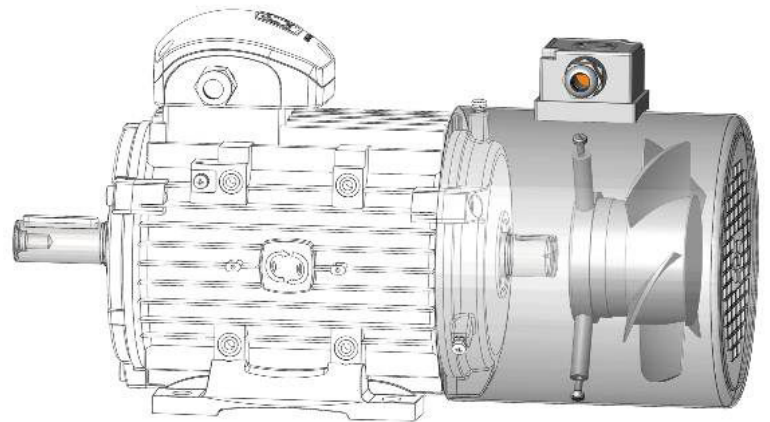

## Encoder

According to the requested ventilation, encoders can be mounted by Rotomotive in the 2 following ways. Rotomotive recommends the encoder types that it selected. Their features can be communicated upon request.(Only for OEMS)

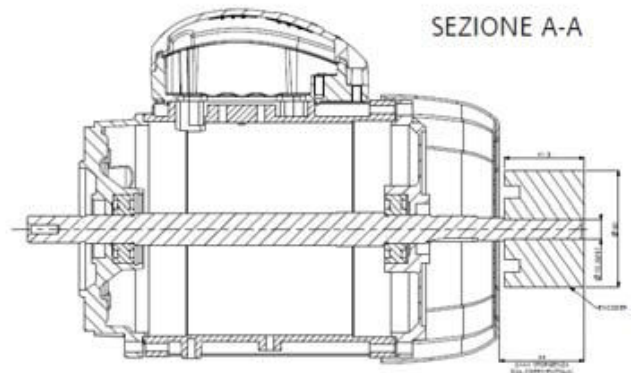
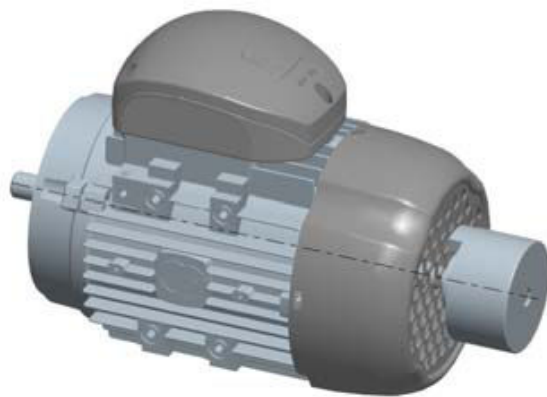
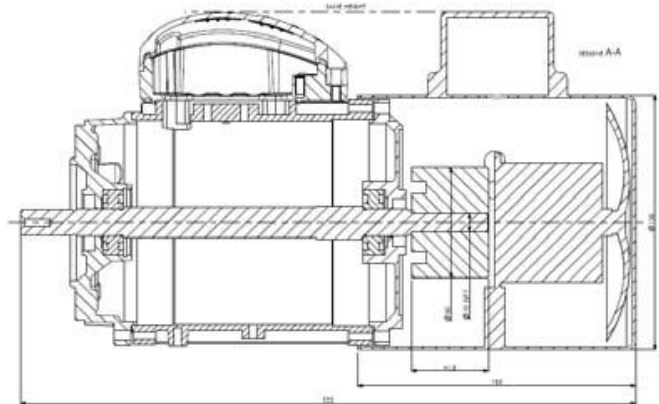
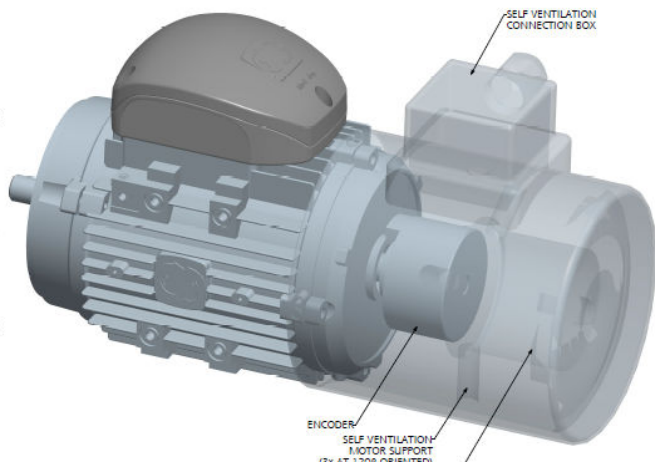

## Earth connection

Earth connection can be done either inside the terminal box (Fig.1) or by using the screw on the housing (Fig.2). This last connection can be requested when the cable going into the terminal box is a 3 wires cable, without the earth one, or when prescribed by some norms, or to connect in series several motors earth by connecting their frames each other, or in customized motors without terminal block and terminal box.

Fig. 2

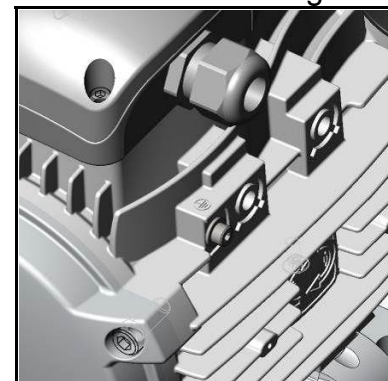
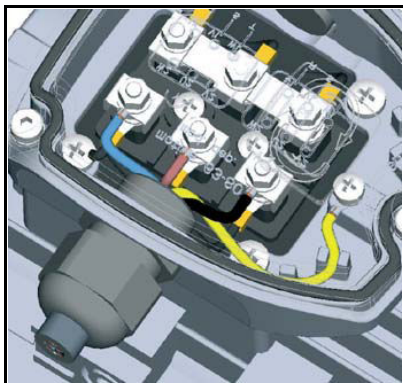

Fig. 1

## Transportation, conservation, use and maintenance

- Rotomotive dispatches the motors in packaging suitable for any kind of transportation. Before any maintenance intervention make sure that the power supply of the motor is off disabling it.
- Use only original spare parts following the indications provided in the catalogue for the motors
- The motor must be conserved in covered and dry ambient, without the presence of vibrations or dust, a temperature higher then  $-15^{\circ}\text{C}$ .
- The exposed parts, like flanges and the shaft drive extremity, must be protected by lubricant. It is opportune to rotate periodically the shaft in order to ensure a long-standing complete lubrication of the bearings.
- The motor must be installed and used by qualified people that know the safety requirements. Also the installation must happen in dry climate and protected by atmospheric agents. The working temperature and humidity must be within the limits described in the previous paragraph "working conditions". Motor dismantling and assembling must be done by qualified people. Any intervention on the connection box must be done only after having disconnected the power supply.
- Eventual inspections must be done with proper tools, avoiding means that could damage the motor. It is opportune to make periodical inspections, to guarantee the best working conditions and making: motor cleaning, fan cooling verification, eventual abnormal noise and vibration identification. In this last case, check the bearings (see tab.1) and, if necessary, substitute them, as well as the rubber seal rings.

Finally, verify the correct fixture of the motor on the flange or on the feet.

## Installation precautions

For the installation of the motor please consider the following:

- make sure that no damages have occurred during transportation.
- carefully remove the components of the plant from the wrapping material and any other protective devices.
- make sure that the value of the voltage on the rating plate is the same as the voltage of mains.
- the surfaces in contact with the electric bonding and the rating plate must not be varnished.
- set the motor on a flat surface;
- make sure that the bearings or the flange are well fixed and that in case of direct joint the motor is perfectly aligned.
- make the rotor rotate manually in order to verify the absence of any dragging.
- verify the rotation sense removing the joint.
- key (extract) the output components (i.e. joint, belt pulley, etc.) only using apt devices (shrinking-on). Avoid not allowed tension on the pulley (ref. catalogue par. technical sheet).
- in the models in which the shaft is with the end downwards, use the protective cover. If the end of the shaft is upwards, use a cover preventing any penetration of external parts into the fan.
- do not hinder ventilation. The discharged air, together with the air coming from other groups, must not be immediately re-aspirated.
- verify the correct grounding of the motor

### Bearings lubrication (DELPHI 3PH)

Motors with rugged bearings, that are self-lubricating for life, do not require any lubrication. Bearings life vary from 3 up to 5 years according to the axial and radial loads that are charged on the shaft and to environmental conditions the motor is used in.

Motors from size 180 provided with the bearings lubrication unit are to be lubricated while running according to the lubricating intervals and the grease quantity as per table 2. On roller "NU" bearings and oblique contact "7.." bearings, the lubrication intervals timing is half

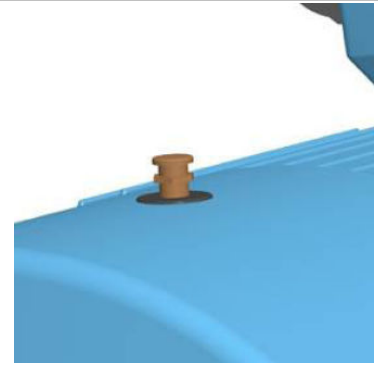

Use lithium grease with mineral oil basis suitable for a max working temp. of at least 130°C

motor size	Grease quantity (g)		Lubrication intervals in operation hours			
	2 poles	4-6-8 poles	2 Poles	4 Poles	6 Poles	8 Poles
180-200	25		3800	9300	12400	15200
225	25		3800	8900	12200	14800
250	30		3100	4100	5900	6900
280	28	36	800	3900	5600	6700
315	36	45	800	2300	4100	5100
355	45	60	700	2000	4000	4500

# COMPONENT LIST

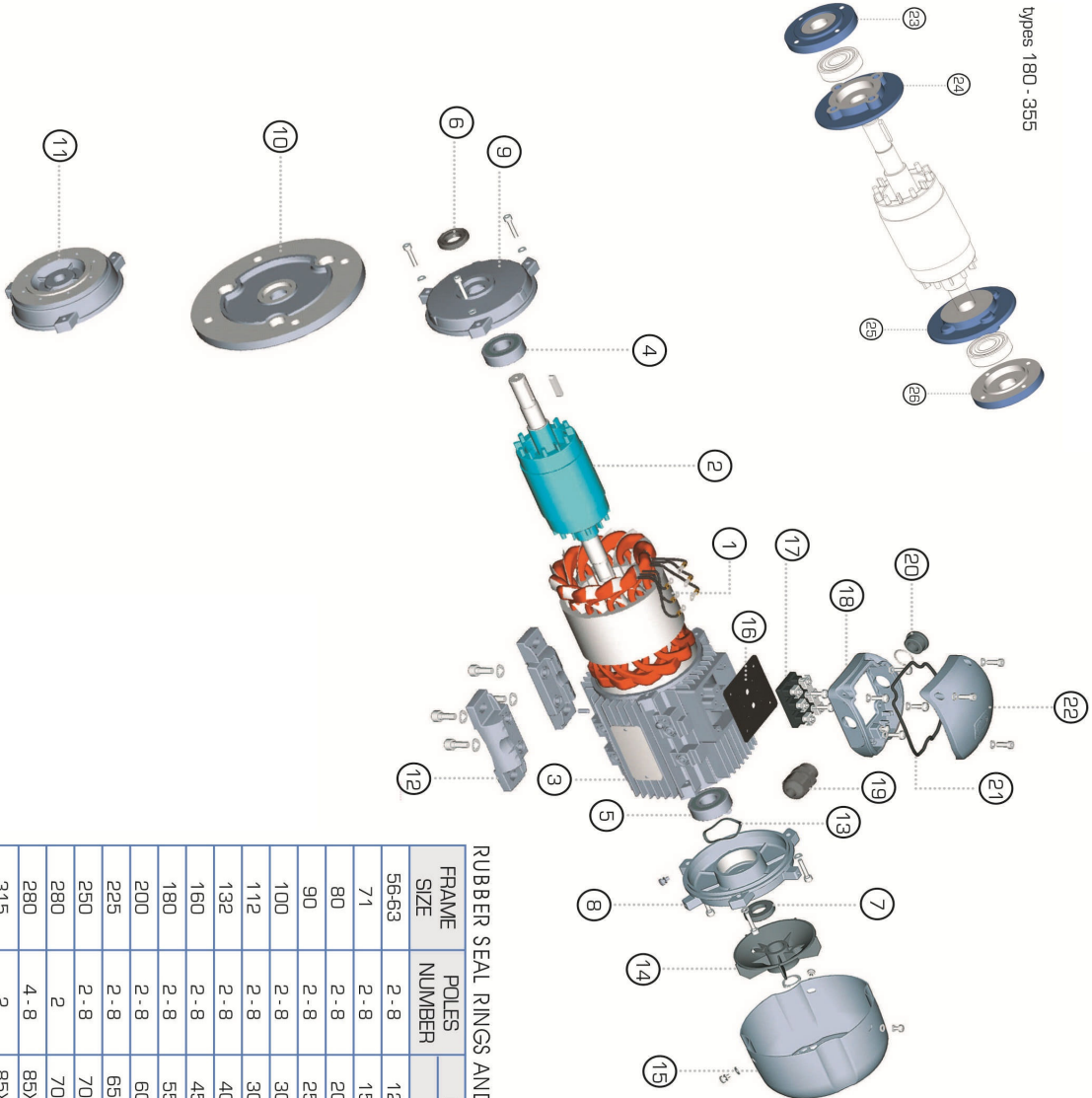

Sr. No.	Description
1	Wound stator with motor body
2	Diecast rotor with shaft
3	Name plate
4	Bearing (DE side)
5	Bearing (NDE side)
6	Oil seal
7	V seal
8	NDE cover
9	DE cover
10	B5 flange
11	B14 flange
12	Foot
13	Wave washer
14	Fan
15	Fan cover (cowl)
16	Rubber gasket
17	Terminal block
18	Terminal box
19	Cable gland
20	Plug
21	O ring
22	Terminal box cover
23	Outside bearing cover (DE side)
24	Inside bearing cover (DE side)
25	Outside bearing cover (NDE side)
26	Outside bearing cover (NDE side)

## RUBBER SEAL RINGS AND BEARINGS

FRAME SIZE	POLES NUMBER	RUBBER SEAL RING		BEARINGS	
		6	7	4	5
56-63	2-8	12X25X7	12X25X7	6201 ZZ	6201 ZZ
71	2-8	15X30X7	15X30X7	6202 ZZ	6202 ZZ
80	2-8	20X35X7	20X35X7	6204 ZZ	6204 ZZ
90	2-8	25X40X7	25X40X7	6205 ZZ	6205 ZZ
100	2-8	30X47X7	30X47X7	6206 ZZ	6206 ZZ
112	2-8	30X47X7	30X47X7	6206 ZZ	6206 ZZ
132	2-8	40X62X7	40X62X7	6208 ZZ	6208 ZZ
160	2-8	45X62X8	45X62X8	6309 ZZ	6309 ZZ
180	2-8	55X72X8	55X72X8	6311-C3	6311-C3
200	2-8	60X80X8	60X80X8	6312-C3	6312-C3
225	2-8	65X80X10	65X80X10	6313-C3	6313-C3
250	2-8	70X90X10	70X90X10	6314-C3	6314-C3
280	2	70X90X10	70X90X10	6314-C3	6314-C3
280	4-8	85X100X12	85X100X12	6317-C3	6317-C3
315	2	85X110X12	85X110X12	6317-C3	6317-C3
315	4-8	95X120X12	95X120X12	NU319-C3	6319-C3
355	2	95X120X12	95X120X12	6319-C3	6319-C3
355	4-8	110X130X12	110X130X12	NU322-C3	6322-C3



max admitted loads

	Fr [N]					Fa1 [N]					Fa2 [N]				
	3000rpm	1500rpm	1000rpm	750rpm		3000rpm	1500rpm	1000rpm	750rpm		3000rpm	1500rpm	1000rpm	750rpm	
56	275	350				120	160				120	160			
63	300	375				120	160				120	160			
71	330	410	480	500		200	250	300	320		200	250	300	320	
80	550	680	800	900		280	340	400	480		280	340	400	480	
90	600	770	880	980		340	450	570	650		340	450	570	650	
100	880	1100	1250	1400		480	590	750	850		480	590	750	850	
112	1000	1200	1400	1500		480	590	750	850		600	700	900	1000	
132	1350	1700	1950	2200		600	1000	1300	1500		600	1300	1700	1950	
160	2300	2700	3000	3300		1300	1500	1900	2200		1300	1500	1900	2200	
180	3000	4000	4800	5300		2400	2700	3000	3300		2400	2700	3000	3300	
200	3800	4800	5500	6000		3000	3900	4800	5400		3000	3900	4800	5400	
225	4200	5200	6000	6600		3800	4900	5700	6500		3800	4900	5700	6500	
250	4800	6000	6800	7500		4100	5500	6500	7300		4175	5500	6500	7300	
280	4800	7800	8800	9800		4100	6800	8100	9100		4100	6800	8100	9100	
315	5800	15000	16000	17500		4800	7800	9000	10100		4800	7800	9000	10100	
355	7700	19000	19000	19000		5800	9900	11500	13000		5800	9900	11500	13000	
400	9000	20500	20500	20500		7300	12500	14800	16700		7300	12500	14800	16700	

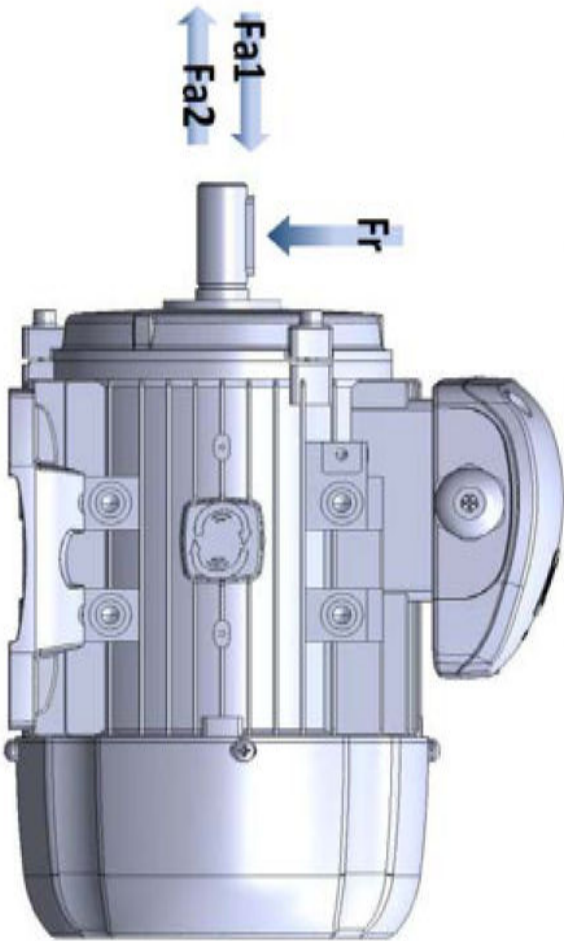

 marking is referred to:

- Community Low Voltage Directive (LVD) 73/23 EEC, modified by the Community Directive regarding marking 93 / 68 EEC

- Community Electromagnetic Compatibility Directive (EMC) 83/336 EEC and its modifications 91/263 Eec , 92/31 EEC and 93/68 EEC

- Community machinery Directive (MD) 89/392 EEC and its modifications 91/368 EEC, 93/44 EEC and 93/68 EEC

CE marking is put as a visible sign of the product compliance with the requirements of above mentioned directives. In order to reach this conformity, Rotomotive products respect the following product standards:

- EN60034-1 (last issue)

- EN60034-1 (last issue)

- EN 60034-5 (last issue)

- EN60034-6 (last issue)

- EN60034-9 (last issue)

- EN50081-1 (last issue)

- EN50081-1 (last issue)

- EN50082-1 (last issue)

- EN50081-2 (last issue)

- EN50081-2 (last issue)

**ALL INFORMATION AND DATA PRESENTED IN THIS INSTRUCTION MANUAL HAS BEEN CHECKED WITH MAXIMUM CARE. WE HOWEVER DO NOT ASSUME RESPONSIBILITY FOR ANY UNINTENDED ERRORS AND OMISSIONS.**

**ROTOMOTIVE RESERVES THE RIGHT TO CHANGE THE SPECIFICATIONS OF ITS PRODUCTS AT ANY TIME.**

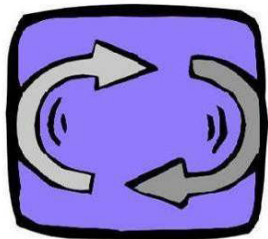

**rotomotive**

*powerdrives*

---

Rotomotive Powerdrives India Ltd.  
223, Napa Talpad,  
Gana-Borsad Road, Tal : Borsad, Anand  
Gujarat – 388 560, INDIA.  
Ph. : +91 – 9227110030  
Fax: +91 – 2692 – 235209  
E-Mail: [info@rotomotive.com](mailto:info@rotomotive.com)  
Web site : [www.rotomotive.com](http://www.rotomotive.com)